



EPD Owner – *Proprietario dell'EPD*
 CBI Europe
 Via Mons. A.O. Romero, 14 - Osimo (AN), Italy

Environmental Product Declaration

In accordance with ISO 14025 and EN 15804:2012+A2:2019

WOOD CEILINGS & COVERING

Dichiarazione Ambientale di Prodotto

Secondo la ISO 14025 e EN 15804:2012+A2:2019+AC

SOFFITTI E RIVESTIMENTI IN LEGNO



Programme: INTERNATIONAL EPD® SYSTEM
www.environdec.com

Programme operator: EPD International AB

EPD registration number: S-P-02547

Approval date: 29-03-2022

Publication date: 29-03-2022

Valid until: 29-03-2027

Geographical Scope: Global

PCR – CPC Code: 2019:14 Construction Products – version 1.11, valid until 2024-12-20 – CPC 412

An EPD should provide current information and may be updated if conditions change. The stated validity is therefore subject to the continued registration and publication at www.environdec.com

Programma: INTERNATIONAL EPD® SYSTEM
www.environdec.com

Operatore del programma: EPD International AB

Numero di registrazione: S-P-02547

Data di approvazione: 29-03-2022

Data di pubblicazione: 29-03-2022

Validità fino al: 29-03-2027

Ambito geografico: Globale

PCR – CPC Code: 2019:14 Construction Products – version 1.11, valid until 2024-12-20 – CPC 412.

Una EPD dovrebbe fornire informazioni aggiornate e potrebbe essere revisionata, qualora le condizioni cambiassero. La validità dichiarata è quindi soggetta a registrazione e pubblicazione continuative su www.environdec.com

1. Company information

Owner of the EPD: CBI EUROPE S.p.A.

Contact: Marrocchini Roberto, email: r.marrocchini@cbi-europe.com

CBI Europe has been producing and supplying innovative, high-tech systems for interior finishes to customers all over the world for thirty years.

CBI Europe is unique in its ability to supply integrated floor, wall and ceiling products, and is the preferred supplier for designers of innovative, stylish, comfortable and technically advanced interiors.

All CBI products are designed for optimum modularity, durability, sound absorption, safety, functionality, versatility, inspectability and rapid installation. CBI products also come in a vast range of colours, finishes and sizes.

Thanks to its strategic location in central Italy, in the heart of the Mediterranean region, and centralised production plant occupying 30,000 m² indoors and 80,000 m² outdoors, CBI Europe is the ideal partner for Middle Eastern, African, Central and Eastern European customers.

All phases of production, from concept to standard or customised finished product, are completed inside CBI Europe's centralised plant in Osimo, in the province of Ancona. The latest generation of automated production machinery and rigorous quality control ensure compliance with all applicable standards. A highly trained and efficient technical staff is always on hand to help in the selection and purchase of products and services, and to assist with design and cost or investment budgeting.

www.cbi-europe.com

1. Descrizione azienda

Proprietario dell'EPD: CBI EUROPE S.p.A.

Riferimento in azienda: Roberto Marrocchini; email: r.marrocchini@cbi-europe.com

CBI Europe produce e commercializza sistemi innovativi e tecnologici per l'allestimento e le finiture d'interni, da trent'anni in tutto il mondo.

Azienda unica nel suo genere, in grado di fornire le tre dimensioni dello spazio in un'ottica integrata, CBI Europe è il riferimento per chi progetta interni innovativi, ricercati, confortevoli e al tempo stesso tecnologicamente avanzati.

Tutti i prodotti sono studiati in un concept di modularità, durevolezza, acustica, sicurezza, funzionalità, versatilità, ispezionabilità e velocità d'installazione e sono disponibili in una gamma infinita di cromie, finiture, dimensioni.

La posizione dell'azienda nel centro Italia, nel cuore della produzione mediterranea, composto da 30.000 m² di superficie coperta con uno spazio esterno di 80.000m², CBI Europe è il partner ideale per clienti in Medio Oriente,

Africa, Centro e mercati dell'Europa orientale.

Il ciclo produttivo si svolge completamente all'interno degli stabilimenti centralizzati di Osimo (AN), dall'idea alla realizzazione del prodotto finito standard o personalizzato, con l'impiego di impianti automatizzati di ultima generazione, ed un rigoroso controllo qualità, in linea con le normative vigenti; uno staff tecnico preparato ed efficiente offre la propria assistenza per agevolare l'accesso ai prodotti, ai servizi e alle prestazioni in fase di progettazione o di elaborazione di budget di costo o di investimento.

www.cbi-europe.com

2. Products included in the EPD - *Prodotti inclusi nell'EPD*

SHERWOOD

Sherwood is CBI Europe's basic line, fire resistant MDF panels and strips, thickness 14 mm. Versions available:

- **Sherwood Real Veneer:** panels with a natural wood finish.
- **Sherwood Melamine:** panels with a melamine finish.

Sherwood panels and strips come in plain, perforated and slotted versions, with nonwoven fabric backing. Sound absorption properties vary according to the type of perforation. Sherwood panels can be installed in suspended ceilings and wall claddings using a variety of mounting systems. Suspended ceilings can use open or closed grids.

Sherwood è la linea basic di CBI Europe composta da pannelli e doghe in MDF ignifugo, spessore 14 mm. Disponibile in versione:

- **Sherwood Real Veneer:** pannelli con finitura legno naturale.
- **Sherwood Melamine:** pannelli con finitura melaminico.

Pannelli e doghe sono realizzati nelle versioni liscia, forata o asolata, con tessuto non tessuto fonoassorbente applicato sul retro, e differenti proprietà fonoassorbenti a seconda della foratura. Possono essere installati a soffitto o a parete, seguendo diversi schemi di montaggio. I controsoffitti sono montati con orditura a vista oppure nascosta



MDF products contain formaldehyde, a substance of very high concern (SVHC) and is subject to authorization under the REACH regulation.

I prodotti in MDF contiene formaldeide, una sostanza estremamente preoccupante (SVHC) ed è soggetta ad autorizzazione ai sensi del regolamento REACH.

SHERWOOD · MDF HIGH DENSITY *MDF ALTA DENSITÀ*

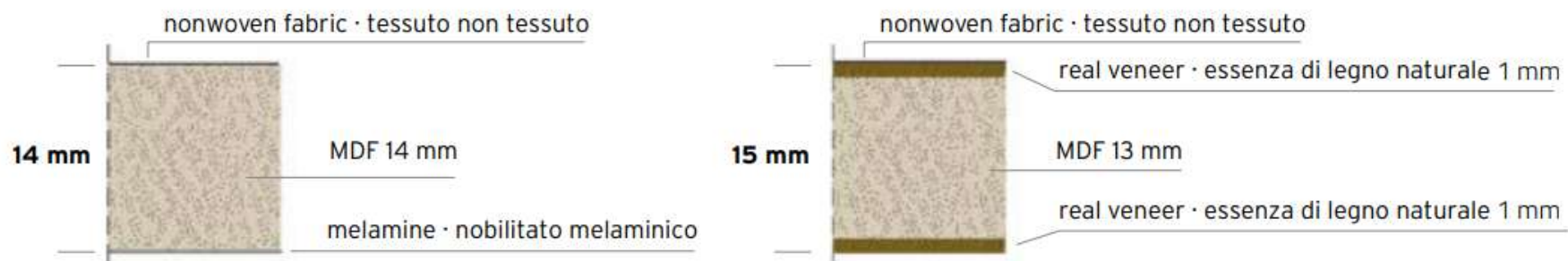

MDF HIGH DENSITY · *MDF ALTA DENSITÀ*

Internal bond · <i>Resistenza allo strappo</i>	EN 319	0,65 / 1,1 N/mm ²
C.R.F.	EN 310	22 / 35,1 N/mm ²
M.O.E.	EN 310	2500 3180 N/mm ²
Thickness swelling 24H (max) · <i>Rigonfiamento 24H (max)</i>	EN 317	15,0 / 12,3 %
Surface soundness · <i>Strappo superficiale</i>	EN 311	1,2 / 1,8 N/mm ²
MDF Density · <i>Densità</i>	EN 323	780 Kg/m ³ +/- 5%
Thickness Tolerance · <i>Tolleranza di spessore</i>	EN 324-1	+/- 0,2 mm
Length and width tolerance · <i>Tolleranza lunghezza e larghezza</i>	EN 324-1	+/- 0,3 mm
Squareness · <i>Squadro</i>	EN 324-2	+/- 0,3 mm
Moisture content · <i>Umidità</i>	EN 322	4% - 11%
Grit content · <i>Contenuto in silice</i>	ISO 3340	< 0,05%
Formaldehyde · <i>Formaldeide</i>	EN 120	< 9 mg / 100 g
Fire reaction class · <i>Classe di reazione al fuoco</i>		B s₂ d₀

ACOUSTIK PLUS

Acoustik Plus is CBI Europe's Hi-tech revolution line that guarantees:

- **Fire resistance**
- **Dimensional stability**
- **Resistance to humidity**
- **Excellent acoustic performance**

Panels consist of high density plaster fibreboard 1250 kg/m³ (class A1) thickness 14 mm., natural wood veneer essences, and the edges are of genuine solid wood. The wood covering and backing are both treated with special fire resistant coatings, which are guaranteed by their manufacturers, thus giving the panels the result of sheer excellence.

Acoustik Plus é la linea Hi-tech revolution di CBI Europe che garantisce:

- ***Resistenza al fuoco***
- ***Stabilità dimensionale***
- ***Resistenza all'umidità***
- ***Performance acustiche eccellenti***

Composta da elementi in gesso/fibre di legno, ad altissima densità 1250 kg/m³ (classe A1) spessore 14 mm, impiallacciati con essenze di legno naturale e bordati con massello di vero legno. Il rivestimento, a vista e sul retro, è trattato con vernici intumescenti garantite dai produttori. Per un risultato finale di pura eccellenza



FIRE RESISTANCE
*RESISTENZA
AL FUOCO*



POINTS LEED CERTIFICATION
PUNTEGGIO LEED



ACOUSTIC ABSORPTION
FONDOASSORBENZA



INSPECTABLE
ISPEZIONABILE



**EXTENDED
WORKING LIFE**
DURABILITÀ



MOISTURE RESISTANCE
RESISTENZA ALL'UMIDITÀ



FSC WOOD CERTIFIED
LEGNO CERTIFICATO FSC



ANTI-SEISMIC
ANTI SISMICO



high density plaster fibreboards
gesso/fibre di legno ad alta densità

ACOUSTIK PLUS · FIRE-PROOF PLASTER FIBREBOARD *GESSO/FIBRE DI LEGNO*

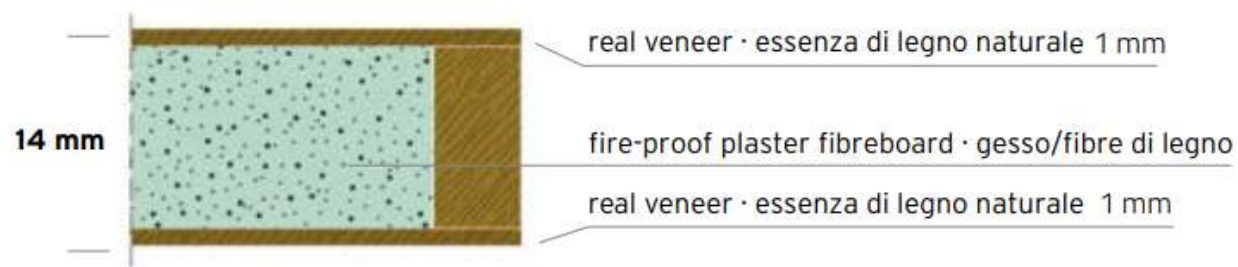

FIRE-PROOF PLASTER FIBREBOARD · *GESSO/FIBRE DI LEGNO*

Internal bond · <i>Resistenza allo strappo</i>	EN 319	0,35 / 1,1 N/mm ²
C.R.F.	EN 310	9 N/mm ²
M.O.E.	EN 310	4000 N/mm ²
Thickness swelling 24H (max) · <i>Rigonfiamento 24H (max)</i>	EN 317	0,08 %
Surface soundness · <i>Strappo superficiale</i>	EN 311	18 N/mm ²
Thickness Tolerance · <i>Tolleranza di spessore</i>	EN 324-1	+/- 0,5 mm
Length and width tolerance · <i>Toll. lunghezza e larghezza</i>	EN 324-1	+/- 0,3 mm
Squareness · <i>Squadro</i>	EN 324-2	+/- 0,3 mm
Moisture content · <i>Umidità</i>	EN 322	2%
Grit content · <i>Contenuto in silice</i>	ISO 3340	0
Formaldehyde · <i>Formaldeide</i>	EN 120	0
Fire reaction class · <i>Classe di reazione al fuoco</i>		A2 s1 d0

SOUND WOOD

Harmony, warmth, perfect acoustics, that is what you get from Sound Wood Ceilings and Wall Panels.

With a series of sound-absorbing elements having open horizontal or vertical slots and through perforation, and a wide range of colours and finishes, this system guarantees excellent acoustic results.

It is ideal for auditoriums, theatres, airports, conference rooms, offices and all environments which need to be elegant and at the same time, be soundproofed. Sound Wood is the perfect solution for the best designers who face the problems of acoustic correction.

Armonia, calore, acustica perfetta: questo è Sound Wood Ceilings & Wall Panels di CBI Europe.

Con una serie di elementi fonoassorbenti che presentano fresature orizzontali o verticali a vista e fori passanti, in una vasta gamma di colori ed elementi di finitura, questo sistema garantisce risultati acustici di eccellenza.

Ideale per auditorium, teatri, aeroporti, sale conferenza, uffici e per tutti gli ambienti che richiedono l'utilizzo di materiali acusticamente performanti ed esteticamente raffinati. È la risposta concreta alle esigenze dei migliori progettisti che affrontano il problema della correzione acustica.

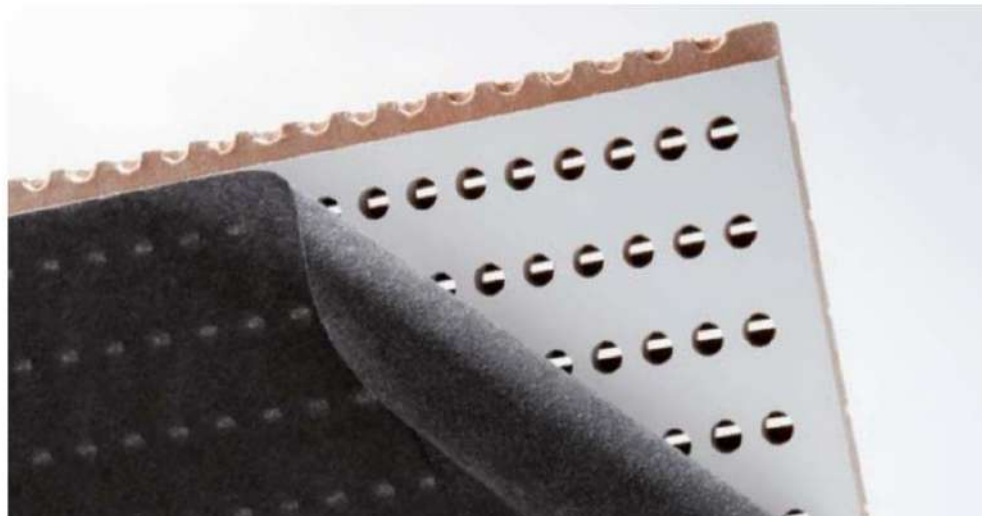

MDF products contain formaldehyde, a substance of very high concern (SVHC) and is subject to authorization under the REACH regulation.

I prodotti in MDF contengono formaldeide, una sostanza estremamente preoccupante (SVHC) ed è soggetta ad autorizzazione ai sensi del regolamento REACH.

SOUND WOOD · MDF HIGH DENSITY *MDF ALTA DENSITÀ*

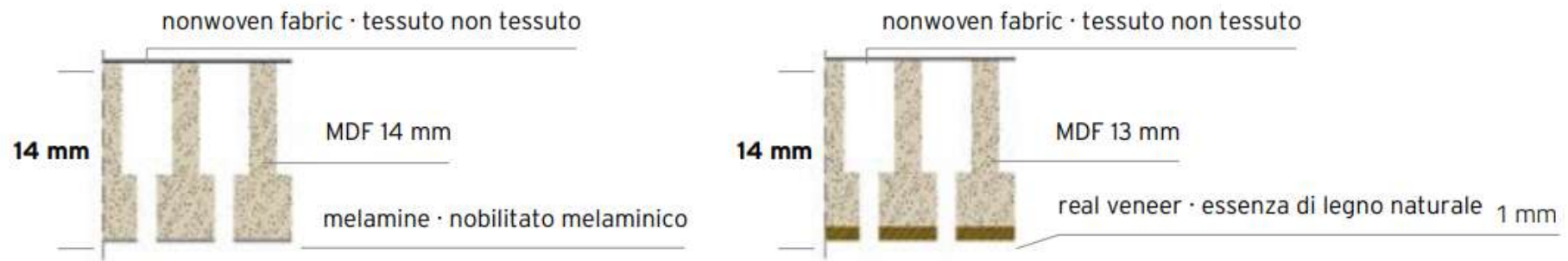

MDF HIGH DENSITY · *MDF ALTA DENSITÀ*

Internal bond · <i>Resistenza allo strappo</i>	EN 319	0,65 / 1,1 N/mm ²
C.R.F.	EN 310	22 / 35,1 N/mm ²
M.O.E.	EN 310	2500 3180 N/mm ²
Thickness swelling 24H (max) · <i>Rigonfiamento 24H (max)</i>	EN 317	15,0 / 12,3 %
Surface soundness · <i>Strappo superficiale</i>	EN 311	1,2 / 1,8 N/mm ²
MDF Density · <i>Densità</i>	EN 323	780 Kg/m ³ +/- 5%
Thickness Tolerance · <i>Tolleranza di spessore</i>	EN 324-1	+/- 0,2 mm
Length and width tolerance · <i>Tolleranza lunghezza e larghezza</i>	EN 324-1	+/- 0,3 mm
Squareness · <i>Squadro</i>	EN 324-2	+/- 0,3 mm
Moisture content · <i>Umidità</i>	EN 322	4% - 11%
Grit content · <i>Contenuto in silice</i>	ISO 3340	< 0,05%
Formaldehyde · <i>Formaldeide</i>	EN 120	< 9 mg / 100 g
Fire reaction class · <i>Classe di reazione al fuoco</i>		B s₂ d₀

LAMELLA SYSTEM

Varying slat size, gaps between slats, and the insulation and cavity depth to the rear of the panel control the sound absorption produced. Our unique suspension system makes mounting and demounting easy, is durable and reliable, and is aesthetically very discrete.

- **Modern aesthetics for environments with a welcoming and natural atmosphere.**
- **Exclusive in-line assembly structure: simple, quick to install, with customizable gap on request.**
- **Seismic safety.**

Le dimensioni variabili delle lamelle, gli spazi tra le lamelle e l'isolamento e la profondità della cavità sul retro del pannello controllano l'assorbimento acustico prodotto. Il nostro esclusivo sistema di sospensione facilita il montaggio e lo smontaggio, è durevole e affidabile ed esteticamente molto discreto.

- ***Estetica moderna per ambienti dall'atmosfera accogliente e naturale.***
- ***Struttura esclusiva di montaggio in linea: semplice, veloce da installare.***
- ***Sicurezza antisismica.***



EUROCLASS
B s2 d0



POINTS LEED CERTIFICATION
PUNTEGGIO LEED



FSC WOOD CERTIFIED
LEGNO CERTIFICATO FSC



ANTI-SEISMIC
ANTI SISMICO



INSPECTABLE
ISPEZIONABILE



QUICK INSTALLATION
INSTALLAZIONE RAPIDA



ACOUSTIC ABSORPTION
FONOASSORBENZA



EXTENDED
WORKING LIFE
DURABILITÀ



MDF products contain formaldehyde, a substance of very high concern (SVHC) and is subject to authorization under the REACH regulation.

I prodotti in MDF contiene formaldeide, una sostanza estremamente preoccupante (SVHC) ed è soggetta ad autorizzazione ai sensi del regolamento REACH.

LAMELLA - MDF HIGH DENSITY *MDF ALTA DENSITÀ*

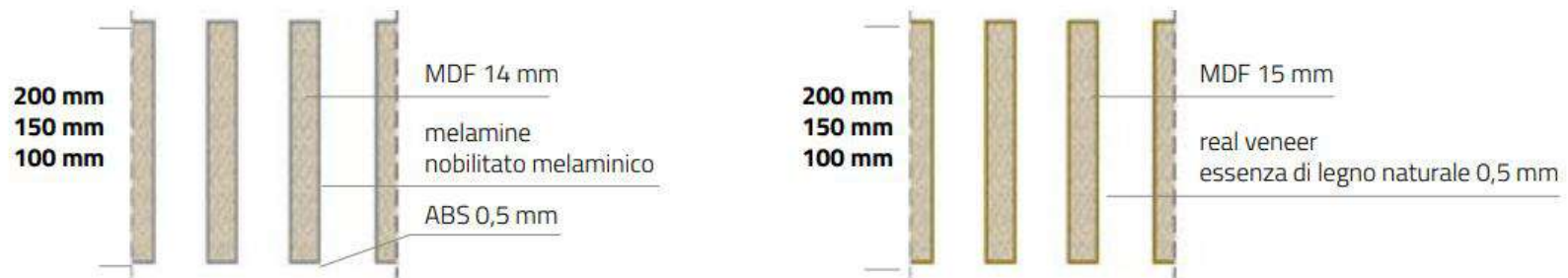

MDF HIGH DENSITY · *MDF ALTA DENSITÀ*

Internal bond · <i>Resistenza allo strappo</i>	EN 319	0,65 / 1,1 N/mm ²
C.R.F.	EN 310	22 / 35,1 N/mm ²
M.O.E.	EN 310	2500 3180 N/mm ²
Thickness swelling 24H (max) · <i>Rigonfiamento 24H (max)</i>	EN 317	15,0 / 12,3 %
Surface soundness · <i>Strappo superficiale</i>	EN 311	1,2 / 1,8 N/mm ²
MDF Density · <i>Densità</i>	EN 323	780 Kg/m ³ +/- 5%
Thickness Tolerance · <i>Tolleranza di spessore</i>	EN 324-1	+/- 0,2 mm
Length and width tolerance · <i>Tolleranza lunghezza e larghezza</i>	EN 324-1	+/- 0,3 mm
Squareness · <i>Squadro</i>	EN 324-2	+/- 0,3 mm
Moisture content · <i>Umidità</i>	EN 322	4% - 11%
Grit content · <i>Contenuto in silice</i>	ISO 3340	< 0,05%
Formaldehyde · <i>Formaldeide</i>	EN 120	< 9 mg / 100 g
Fire reaction class · <i>Classe di reazione al fuoco</i>		B s2 d0

The lamella system is also available in solid fir wood.

Il sistema a lamella è disponibile anche in legno massello di abete.

In order to evaluate the environmental impacts associated with 1 square meter of ceiling realized with MDF and solid wood slats, it has been assumed that these are installed with a pitch equal to 0. In reality, the slats, in 1 square meter of ceiling, are placed at variable distance between them, generally at 10-15 cm. The hypothesis adopted is therefore precautionary and the weight of 1 square meter of ceiling is overestimated.

Per valutare gli impatti ambientali associati ad 1 mq di controsoffitto realizzato con lamelle in MDF e legno massello è stato ipotizzato che queste siano installate con passo pari a 0. Nella realtà le lamelle, in 1 mq di controsoffitto, vengo poste a distanza variabile tra loro, generalmente a 10-15 cm. L'ipotesi adottata è dunque cautelativa e il peso di 1 mq di controsoffitto è sovrastimato.

MDF panels are always used for the special panels and Micro Plus line.

Per la linea pannelli speciali e Micro Plus vengono sempre utilizzati pannelli in MDF.

MICRO PLUS 250 - Invisible drilling, excellent acoustic performance

MICRO PLUS 250 - Foratura invisibile, prestazioni acustiche d'eccellenza

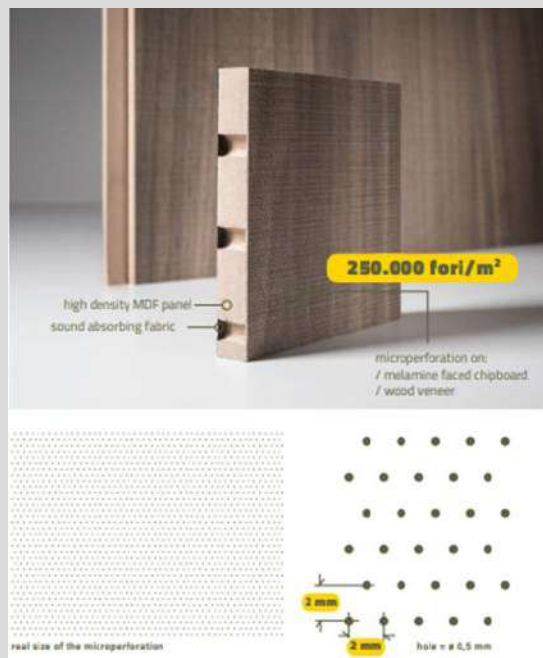

The MICRO PLUS 250 acoustic panel from CBI Europe combines the sound absorption of surface microperforation - invisible at a normal distance - with the acoustic chamber of the MDF body. The result is an innovative panel, with a contemporary feel, which allows for the creation of perceptively continuous and uniform coverings without sacrificing effective control of acoustic correction.

The surfaces maintain all their naturalness - materiality, veining, shade nuances - allowing designers to create extremely comfortable and welcoming environments with a modern and natural aesthetic.

Il pannello acustico MICRO PLUS 250 di CBI Europe combina la fonoassorbente della microforatura superficiale - invisibile ad una distanza normale - con quella della camera acustica del corpo in MDF.

Il risultato è un pannello innovativo, dal mood contemporaneo, che consente di realizzare rivestimenti percettivamente continui ed uniformi senza rinunciare ad un efficace controllo della correzione acustica.

Le superfici mantengono inalterata tutta la loro naturalezza - matericità, venature, sfumature di tonalità - permettendo ai progettisti di creare ambienti estremamente confortevoli ed accoglienti dall'estetica moderna e naturale.

Product detail - *Dettaglio prodotti*

FINISHES *FINITURE*

MELAMINE *NOBILITATO MELAMINICO*

· SHERWOOD · SOUND WOOD · LAMELLA



oak rock white · rovere rock bianca



elm tafira · olmo tafira



oak italia · rovere italia



oak bruges · rovere bruges



walnut athens · noce athens

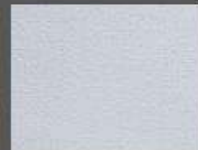

white · bianca

REAL VENEER *IMPIALLACCIATO LEGNO*

· SHERWOOD · ACOUSTIK PLUS · SOUND WOOD · LAMELLA



maple · acero



wengè



beech · faggio



cherry · ciliegio



zebrano



ash tree · frassino



walnut 1 · noce 1



walnut 2 · noce 2



mahogany · mogano



oak · rovere

The colour card shown on this page is purely for information purposes; please request samples. Please contact CBI Europe's Technical Office for special colour requirements which will be supplied only for orders of at least 800 sq.m. Wood system accessories are finished in aluminium or wood.

Le cartelle colori riportate sono puramente indicative, e si raccomanda la richiesta di campionatura. Per colori non presenti in cartella e soltanto per finiture di colore pari o superiori a 800 mq, contattare l'ufficio tecnico. Gli accessori del Sistema Wood possono essere in finitura alluminio o legno.

WOOD EXPO 100 SYSTEM



WOOD CONCEALED 200 SYSTEM

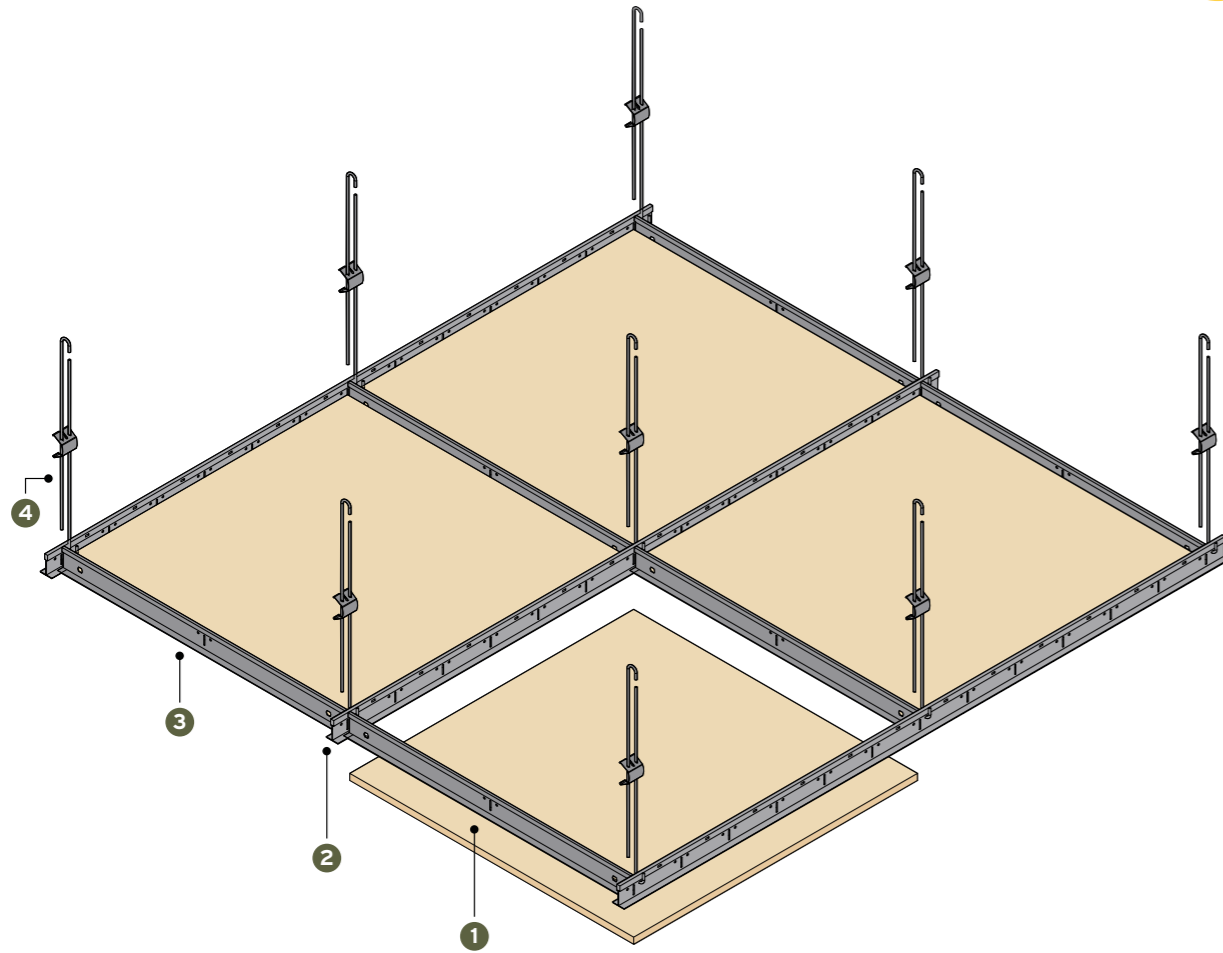

PANEL PANNELLO

dimension	type
square quadrato	· SHERWOOD MELAMINE
rectangular rettangolare	· SHERWOOD REAL VENEER
	· ACOUSTIK PLUS
	· SOUND WOOD

GRID SYSTEM STRUTTURA

- CWT
- CWR
- CWN
- CWX

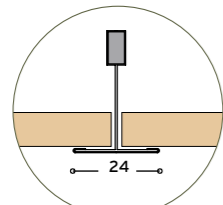

TRIM T24 > CWT

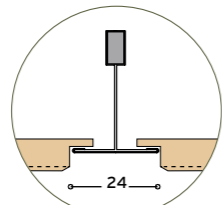

REVEAL T24 > CWR

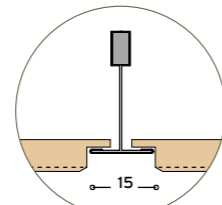

NARROW T15 > CWN

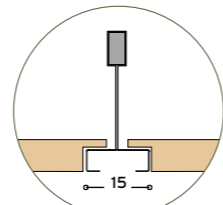

XLINE T15 > CWX

38

1	2	3	4
panel pannello 600x600 mm 600x1200 mm	main runner profilo portante CWT · CWR > PKH 3700 24x38x3700 mm CWN > PKA 3700 15x38x3700 mm CWX > BP 3600 15x42x3600 mm	cross tee profilo intermedio IKH 0600 24x38x600 mm IKHA 0600 24x38x600 mm BP 0600 15x42x600 mm	SOR suspension sospensione

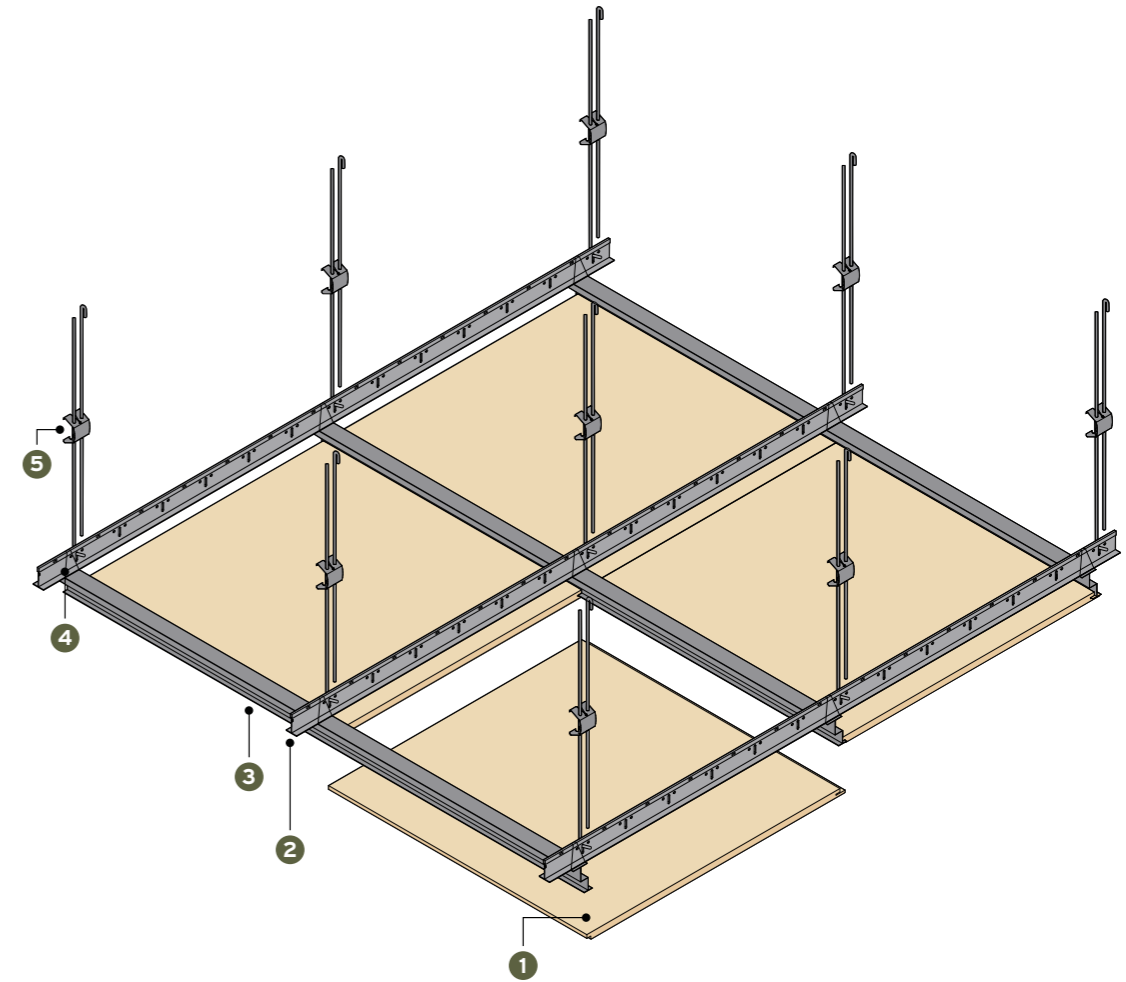

PANEL PANNELLO

dimension	type
square quadrato	· SHERWOOD MELAMINE
rectangular rettangolare	· SHERWOOD REAL VENEER
	· ACOUSTIK PLUS
	· SOUND WOOD

GRID SYSTEM STRUTTURA

- CWI

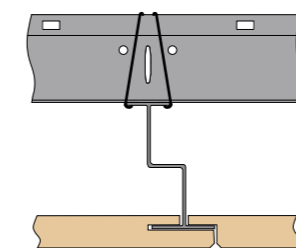

38
56

1	2	3	4	5
panel pannello 600x600 mm 600x1200 mm	P 3700 Z main runner profilo portante 24x38x3700 mm	Z 4000 W secondary profile profilo secondario 24x56x4000 mm	SP 38.1 cross connector raccordo ortogonale	SOR suspension sospensione

WOOD CONCEALED 200 SYSTEM **accessible**



INSPECTABLE
WITH TRAPDOOR
ISPEZIONABILE
CON BOTOLA

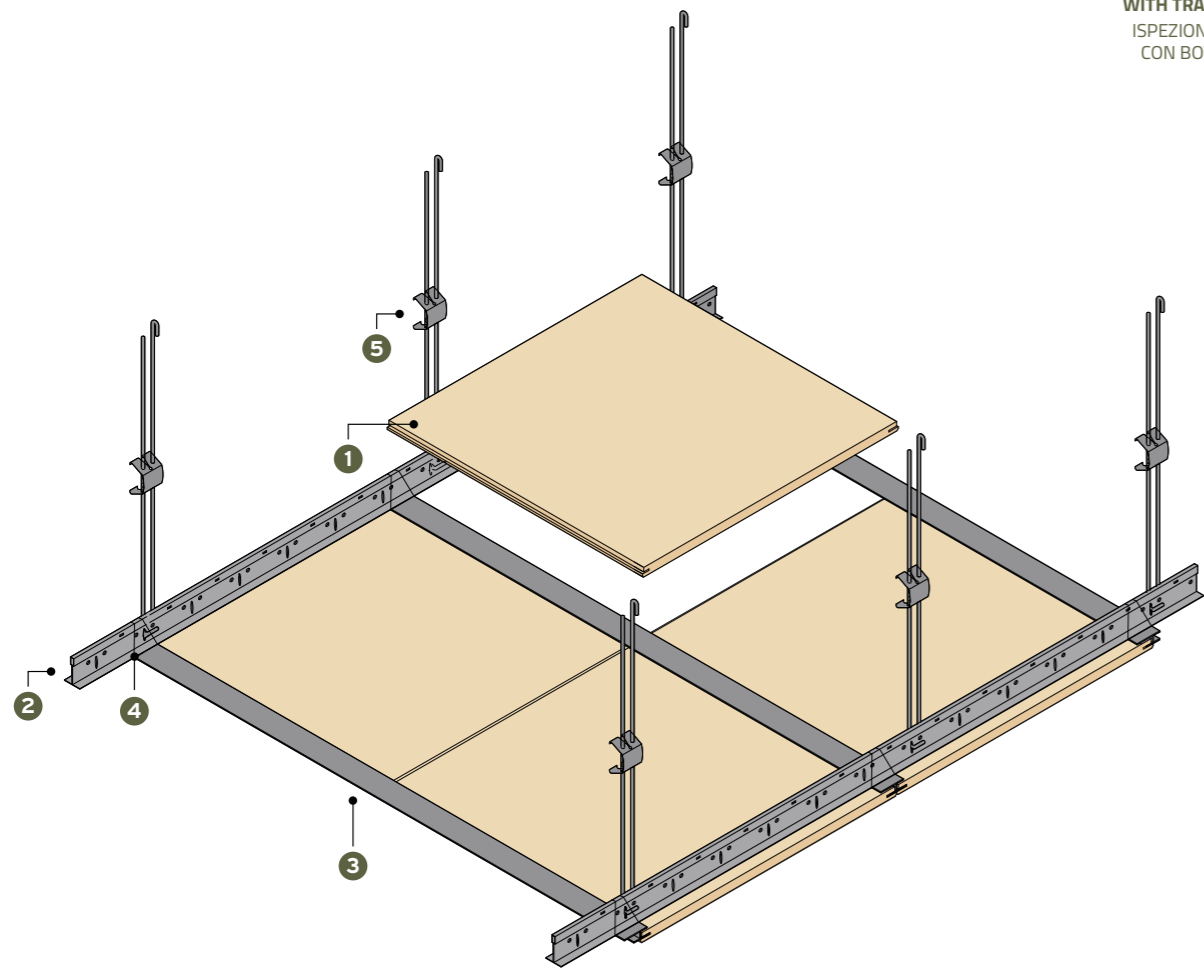

PANEL PANNELLO

dimension	type
square quadrato	· SHERWOOD MELAMINE
rectangular rettangolare	· SHERWOOD REAL VENEER
	· ACOUSTIK PLUS
	· SOUND WOOD

GRID SYSTEM STRUTTURA

· CWA

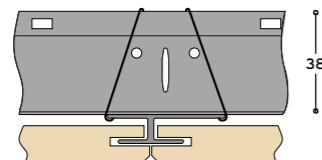

1	2	3	4	5
panel pannello 600x600 mm 600x1200 mm	P 3700 Z main runner profilo portante 24x38x3700 mm	PP 1001 secondary profile profilo secondario 36,5x12x4000 mm	SP 38.1 cross connector raccordo ortogonale	SOR suspension sospensione

WOOD CONCEALED 200 **CWI** SYSTEM

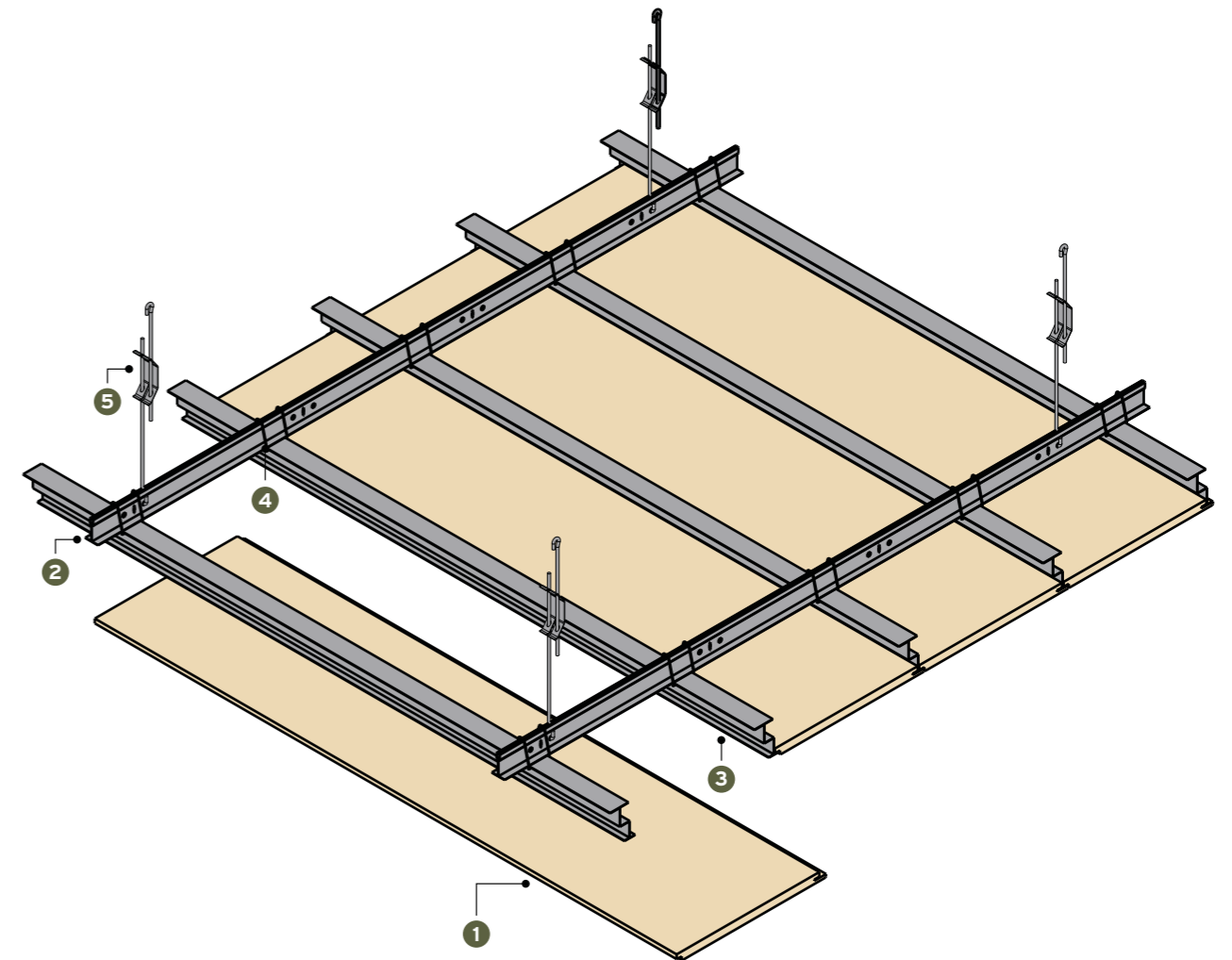

PANEL PANNELLO

dimension	type
square quadrato	· SHERWOOD MELAMINE
rectangular rettangolare	· SHERWOOD REAL VENEER
	· SOUND WOOD*

GRID SYSTEM STRUTTURA

· CWI

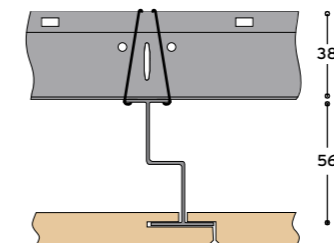

1	2	3	4	5
panel pannello Sherwood 600x600/1200 *Soundwood 256x1792	P 3700 Z main runner profilo portante 24x38x3700 mm	PP 1001 secondary profile profilo secondario 36,5x12x4000 mm	SP 38.1 cross connector raccordo ortogonale	SOR suspension sospensione

WOOD LAMELLA 300 SYSTEM



WOOD LAMELLA 301 SYSTEM

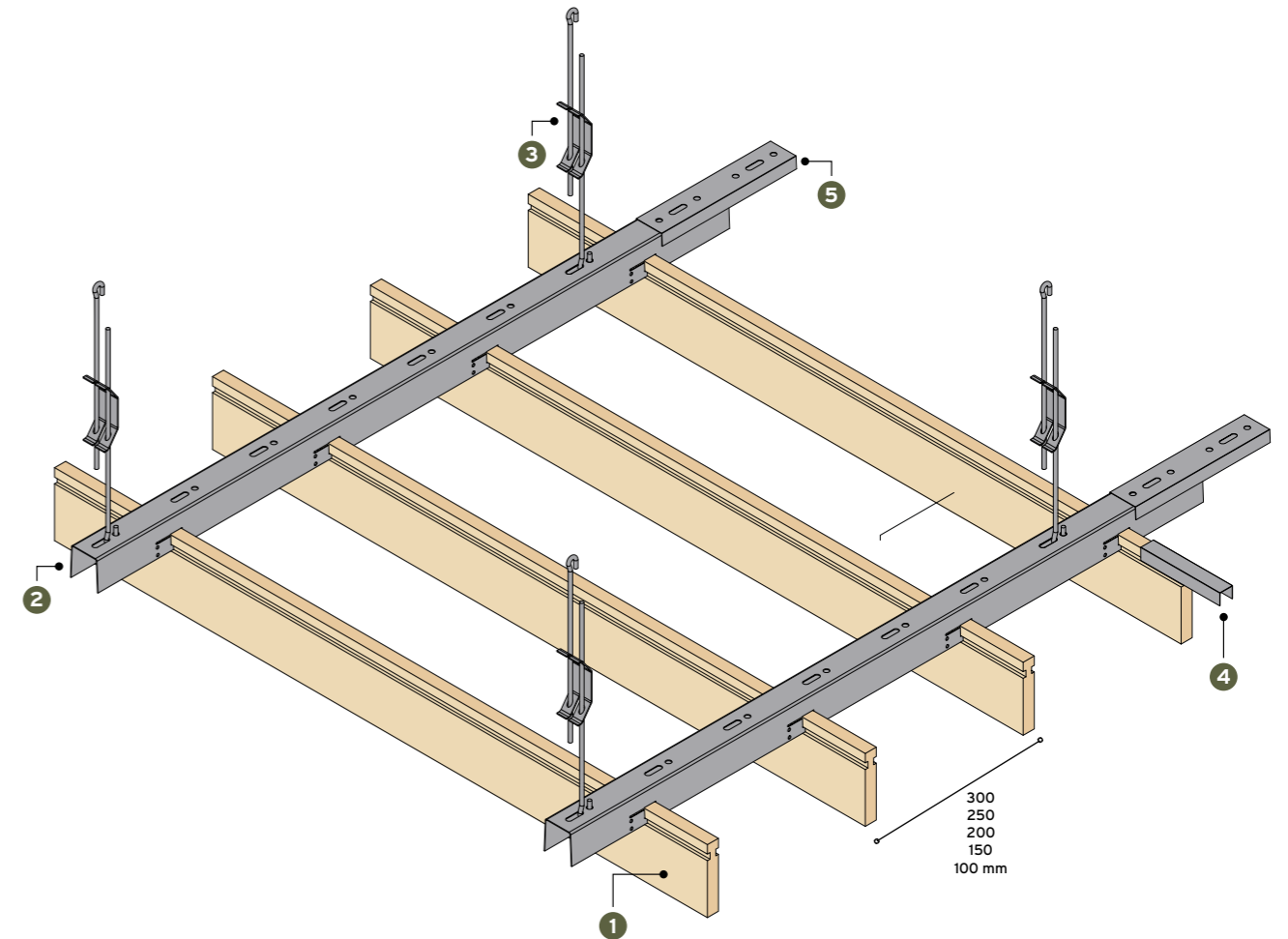
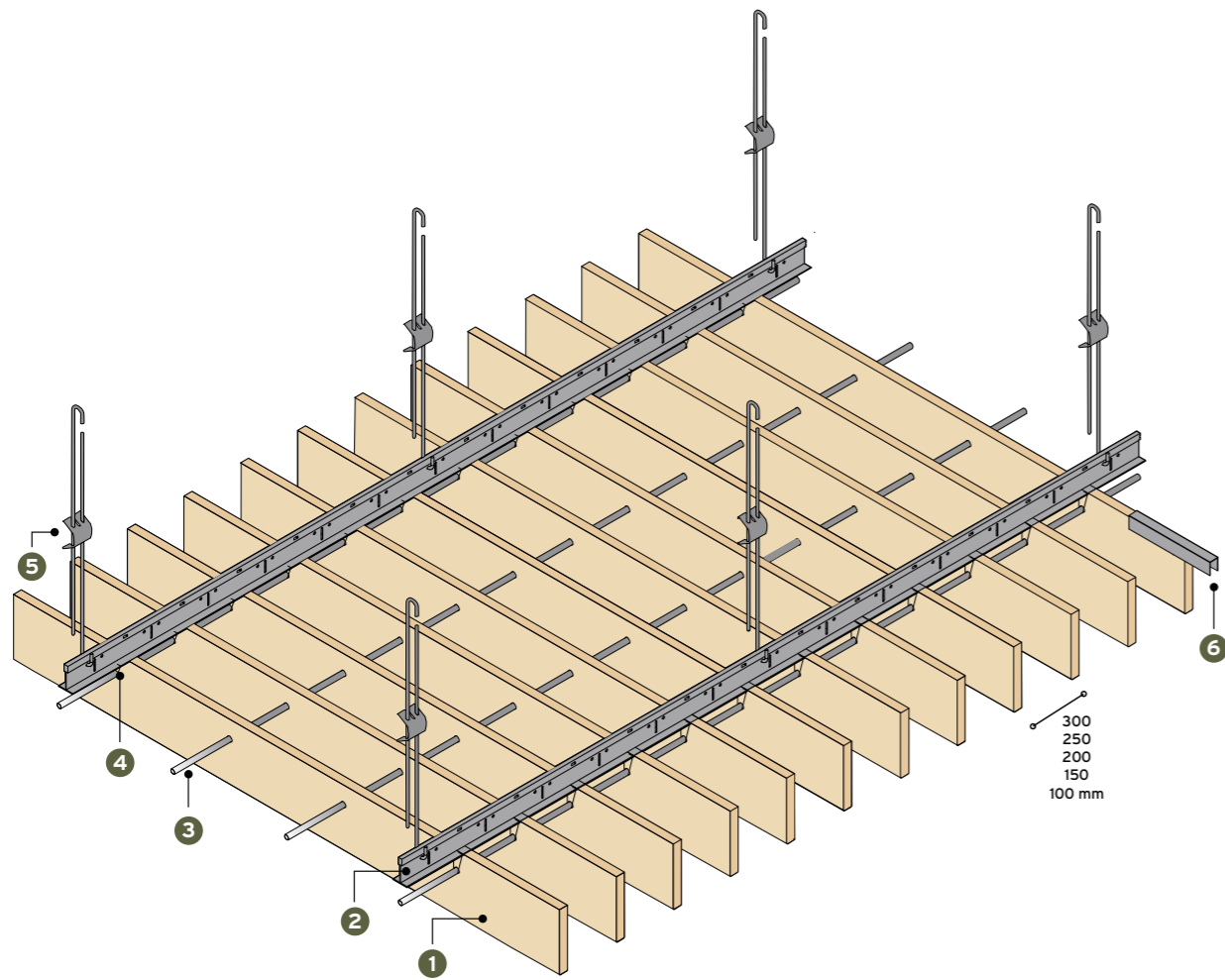

SLAT LAMELLA

dimension
H 100 / 150 / 200 mm
L 1200 / 1800

type
MELAMINE
REAL VENEER

SLAT LAMELLA

dimension
H 100 / 150 / 200 mm
L 1200 / 1800

type
MELAMINE
REAL VENEER

GRID SYSTEM STRUTTURA

· CWG

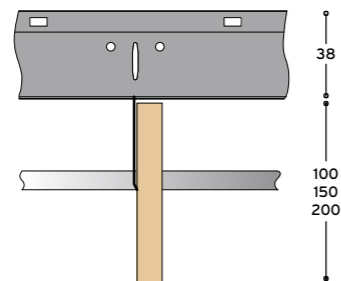

GRID SYSTEM STRUTTURA

· CWF

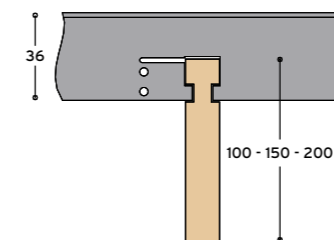

- 1** slat lamella H 100/150 / 200 mm
- 2** **P 3700 N** main runner profilo portante 32x36x4000 mm
- 3** **TU 08** aluminium tube tubolare in alluminio Ø 8 mm
- 4** **SP 39** spring molla
- 5** **SOR** suspension sospensione
- 6** **SP81** connector for slat connettore per lamella

- 1** slat lamella H100/150/200 mm
- 2** **T 91/N** main runner profilo portante 32x36x4000 mm
- 3** **SOR** suspension sospensione
- 4** **SP81** connector for slat connettore per lamella
- 5** **CN81** connector for main runner connettore per profilo portante

SOLID WOOD LAMELLA 302 SYSTEM

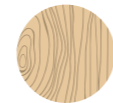

SOLID WOOD

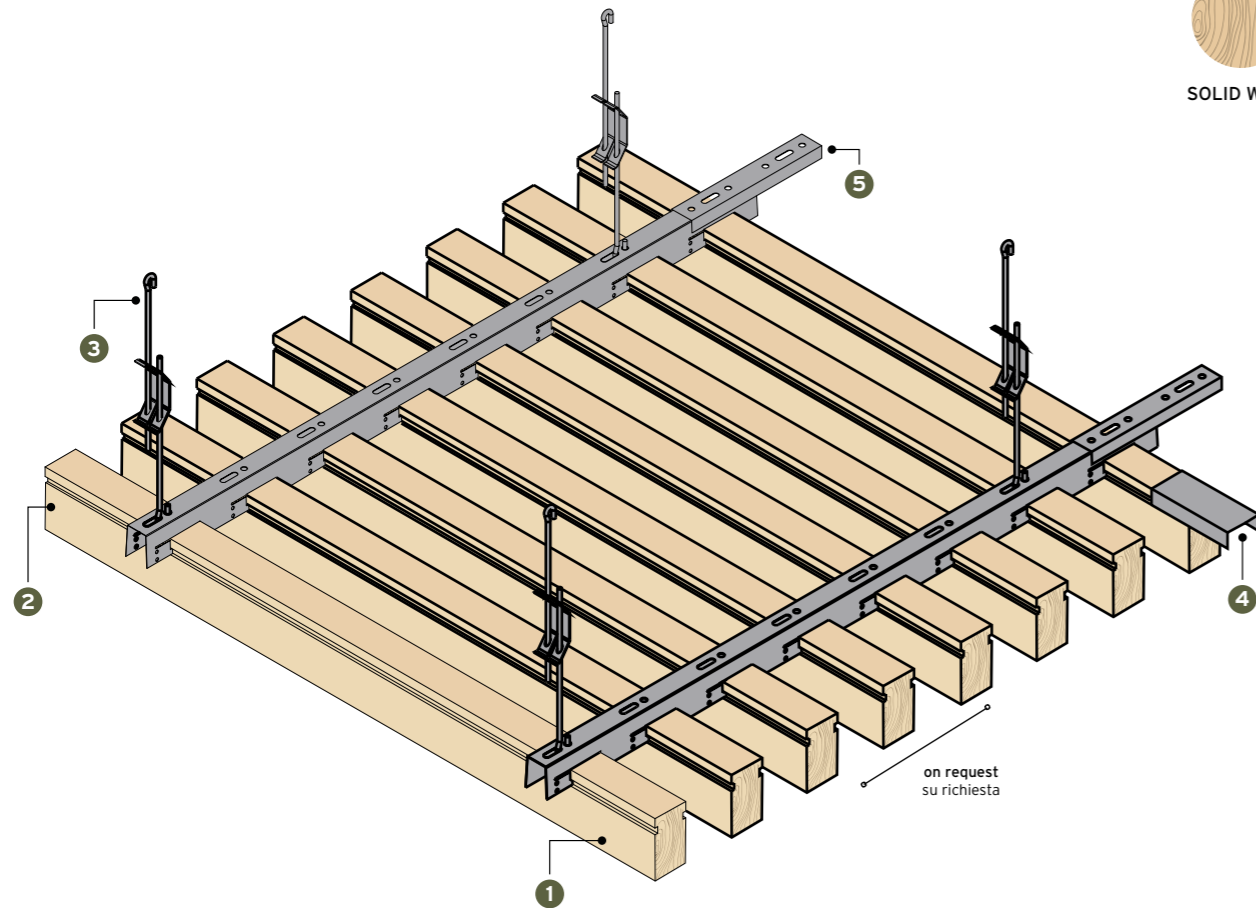

on request
su richiesta

SLAT LAMELLA

dimension type
H 40/50/60 mm SOLID WOOD
L 20/32/40 mm

GRID SYSTEM STRUTTURA

· CWF

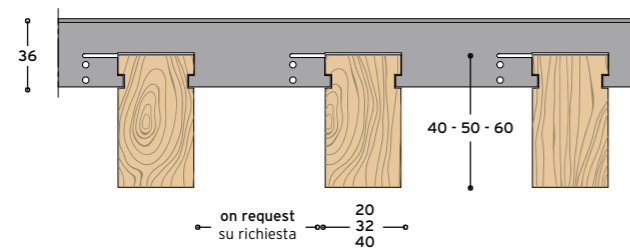

on request
su richiesta

- 1** slat lamella H 40/50/60 mm
- 2** T 91/N main runner profilo portante 32x36x4000 mm
- 3** SOR suspension sospensione
- 4** SP82 connector for slat connettore per lamella
- 5** CN82 connector for main runner connettore per profilo portante

WOOD CONCEALED 400 SYSTEM

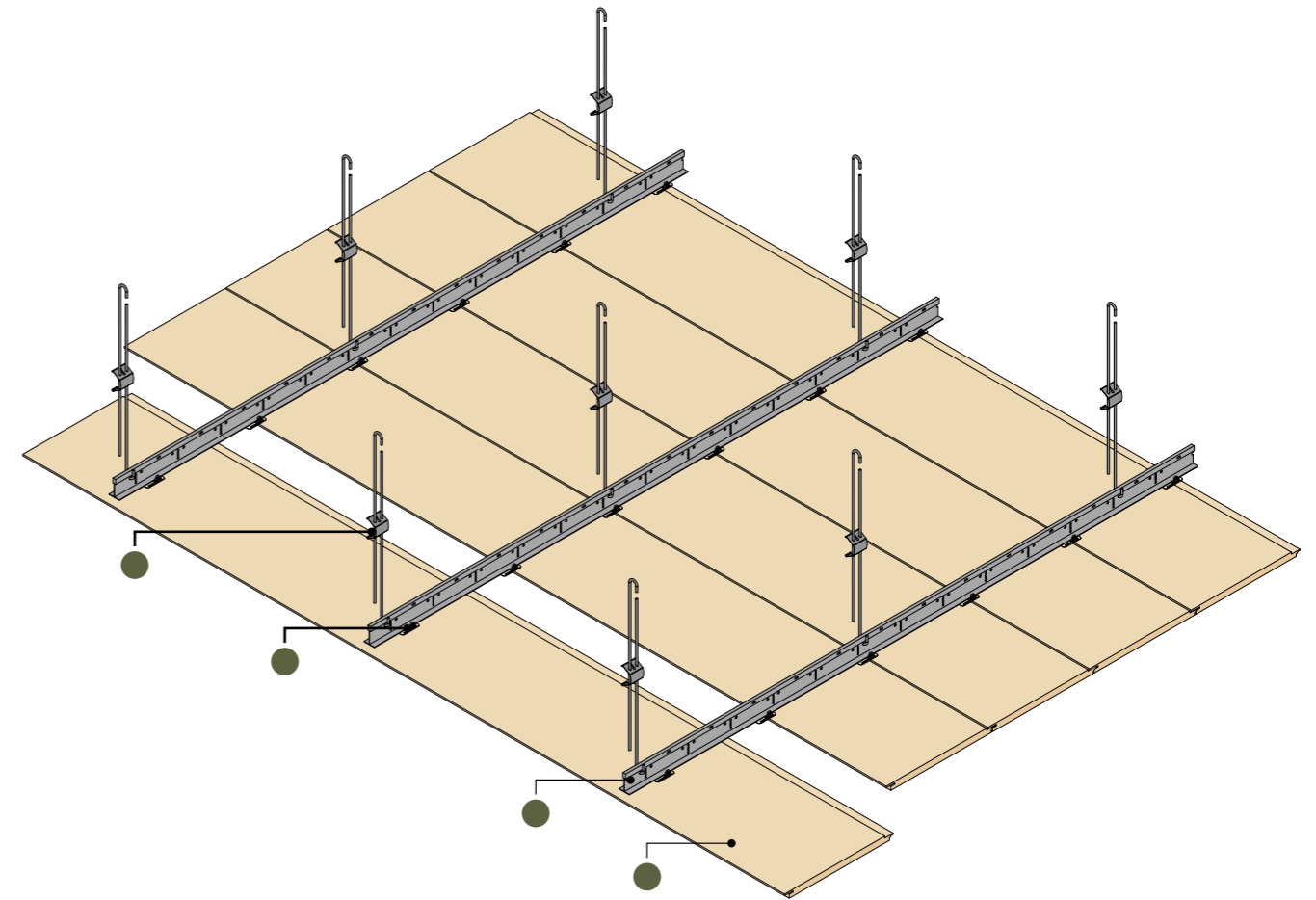

PANEL PANNELLO

dimension type
rectangular rettangolare · SOUND WOOD

GRID SYSTEM STRUTTURA

· CWB

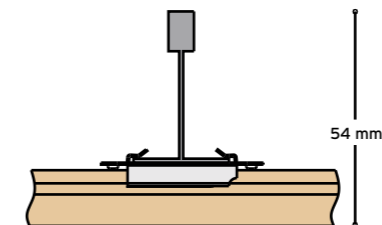

- 1** panel pannello
- 2** P 3700 Z main runner profilo portante 24x38x3700 mm
- 3** SP76 hidden suspension sospensione nascosta
- 4** SOR suspension sospensione

WOOD CONCEALED 401 SYSTEM

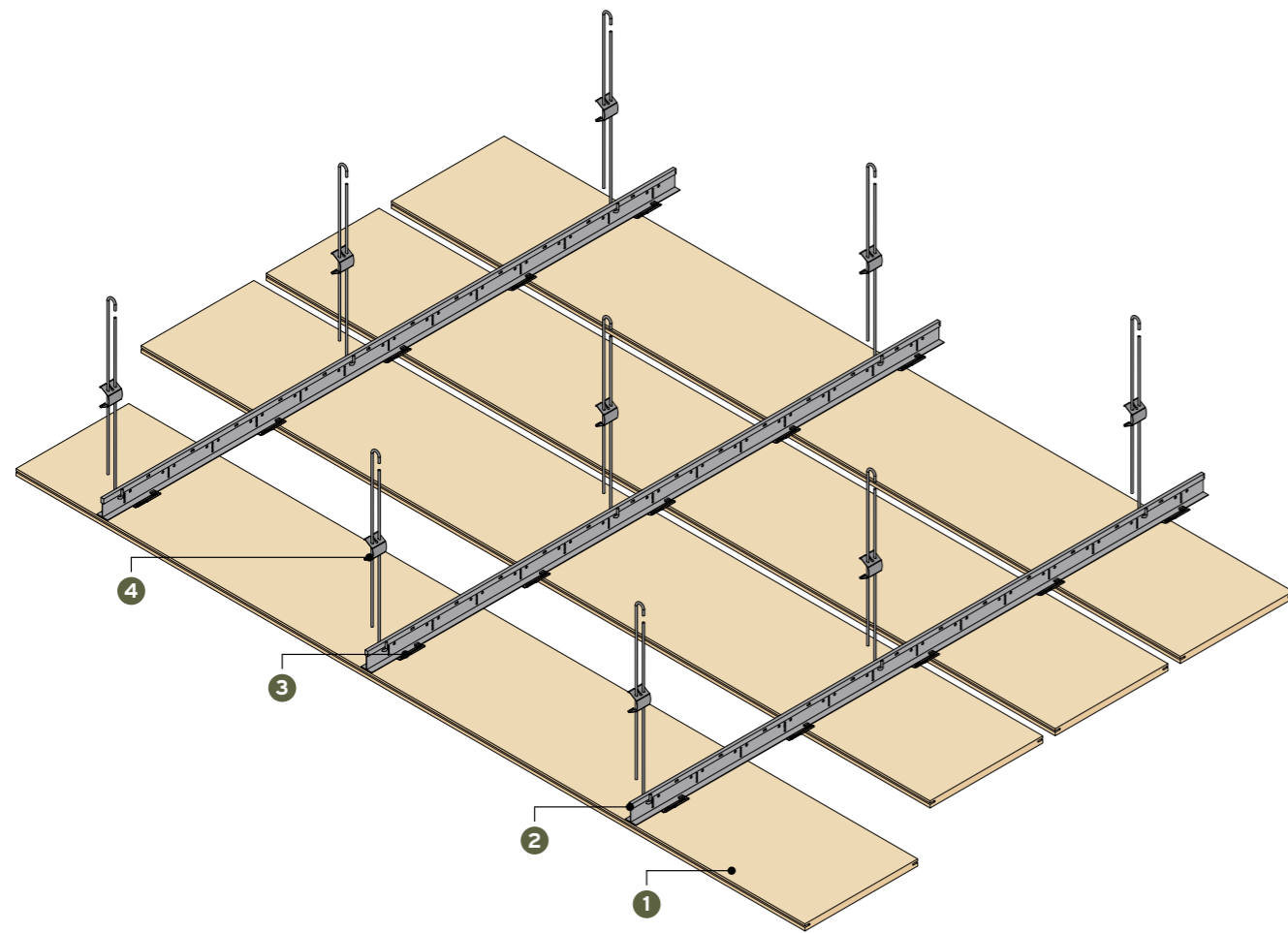

PANEL PANNELLO

dimension
rectangular rettangolare

type
· SOUND WOOD

GRID SYSTEM STRUTTURA

· CWC

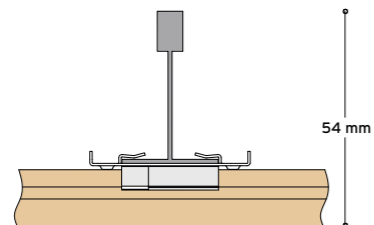

- 1** panel pannello
- 2** **P 3700 Z** main runner profilo portante 24x38x3700 mm
- 3** **SP 78** spacer hook gancio distanziale gap fuga 20 mm
- 4** **SOR** suspension sospensione

WOOD COVERING 500 SYSTEM

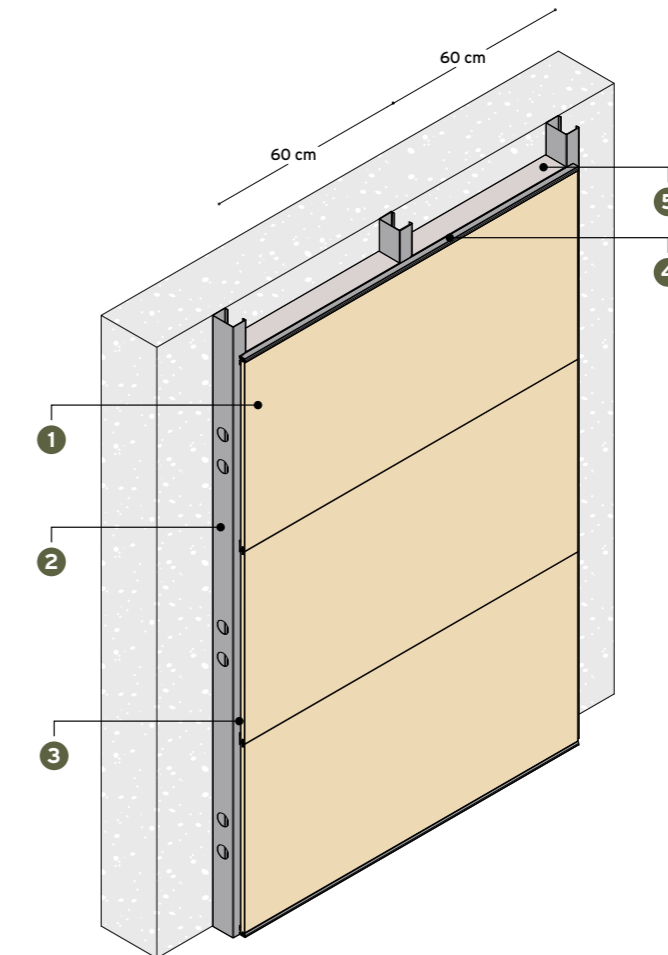

EASY INSPECT



CUSTOM SIZE

PANEL PANNELLO

dimension
square quadrato
rectangular rettangolare

type
· SHERWOOD MELAMINE
· SHERWOOD REAL VENEER
· ACOUSTIK PLUS
· SOUND WOOD

custom su misura

GRID SYSTEM STRUTTURA

· WC1

PP1001 / PP1001.N

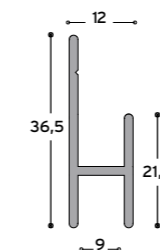

PP1002
Acoustik Plus

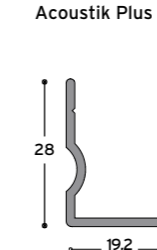

PP1003
Sherwood
Sound Wood

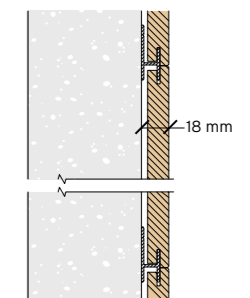
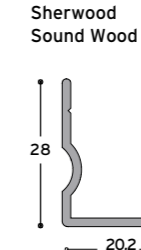

- 1** panel pannello
- 2** **M46 / 75** primary support structure struttura di sostegno primaria
- 3** **PP1001 Acoustik Plus Sherwood** / **PP1001.N Sound Wood** secondary profile profilo secondario
- 4** **PP1002 Acoustik Plus** / **PP1003 Sherwood Sound Wood** starting profile profilo di partenza
- 5** **PPN1 / 40.1** rockwool insulation lana di roccia 600 x 1200 mm

WOOD COVERING 501 SYSTEM

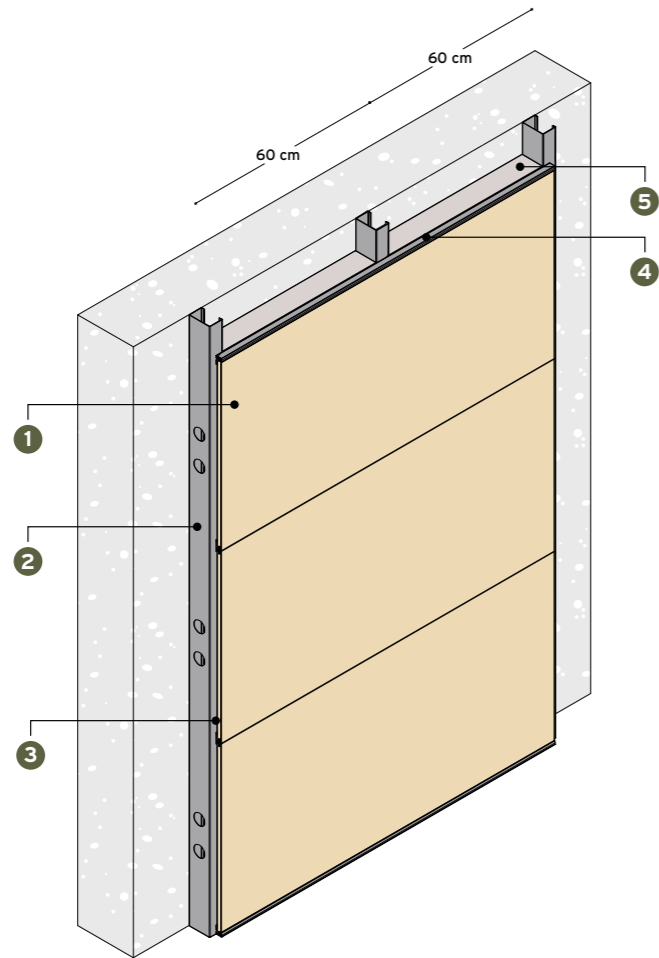

PANEL PANNELLO

dimension type
 square quadrato · SHERWOOD MELAMINE
 rectangular rettangolare · SHERWOOD REAL VENEER
 · ACOUSTIK PLUS
 · SOUND WOOD
 custom su misura

GRID SYSTEM STRUTTURA

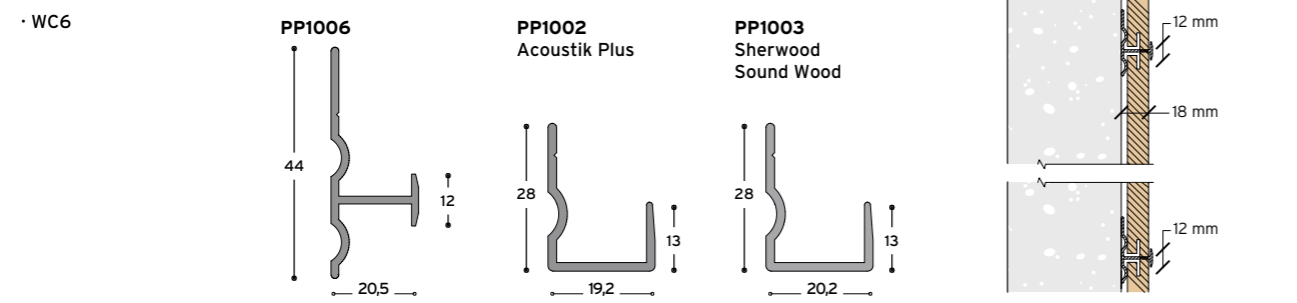

- | | | | | |
|----------------|---|---|---|--|
| 1 | 2 | 3 | 4 | 5 |
| panel pannello | M46 / 75 primary support structure struttura di sostegno primaria | PP1006 secondary profile profilo secondario | PP1002 Acoustik Plus starting profile profilo di partenza
PP1003 Sherwood Sound Wood | PPN1 / 40.1 rockwool insulation lana di roccia 600 x 1200 mm |

WOOD COVERING 502 SYSTEM

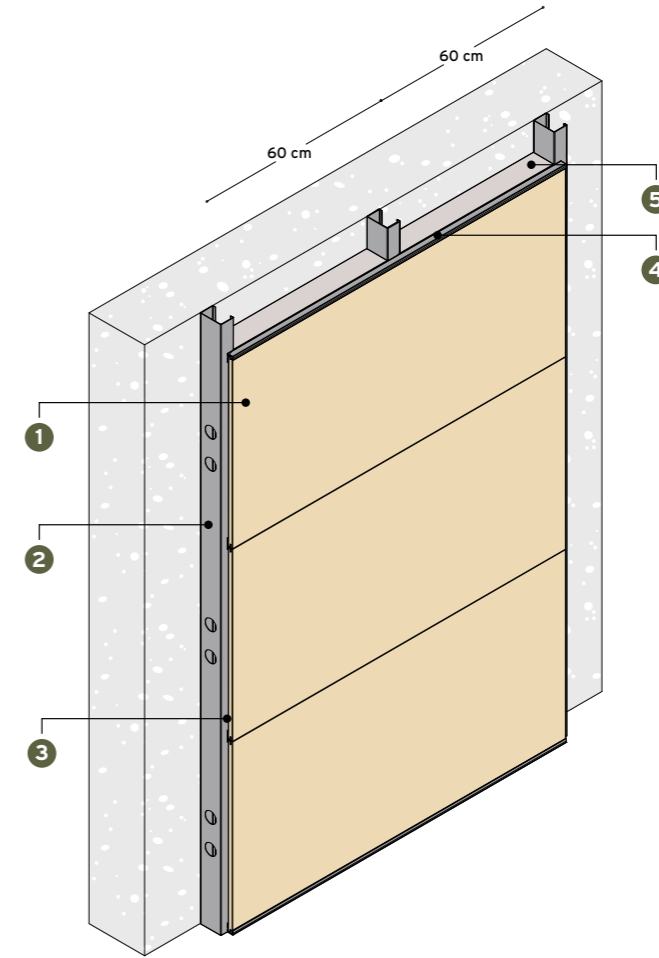

PANEL PANNELLO

dimension type
 square quadrato · SHERWOOD MELAMINE
 rectangular rettangolare · SHERWOOD REAL VENEER
 · ACOUSTIK PLUS
 · SOUND WOOD
 custom su misura

GRID SYSTEM STRUTTURA

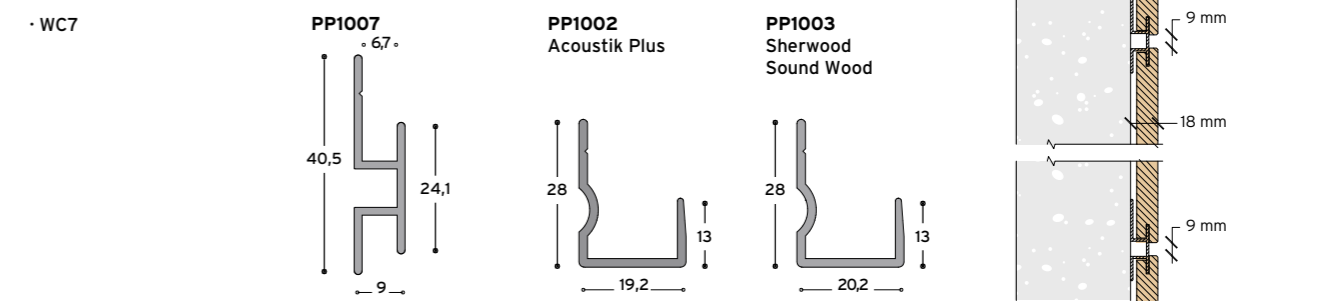

- | | | | | |
|----------------|---|---|---|--|
| 1 | 2 | 3 | 4 | 5 |
| panel pannello | M46 / 75 primary support structure struttura di sostegno primaria | PP1007 secondary profile profilo secondario | PP1002 Acoustik Plus starting profile profilo di partenza
PP1003 Sherwood Sound Wood | PPN1 / 40.1 rockwool insulation lana di roccia 600 x 1200 mm |

WOOD COVERING 503 SYSTEM



EASY INSPECT

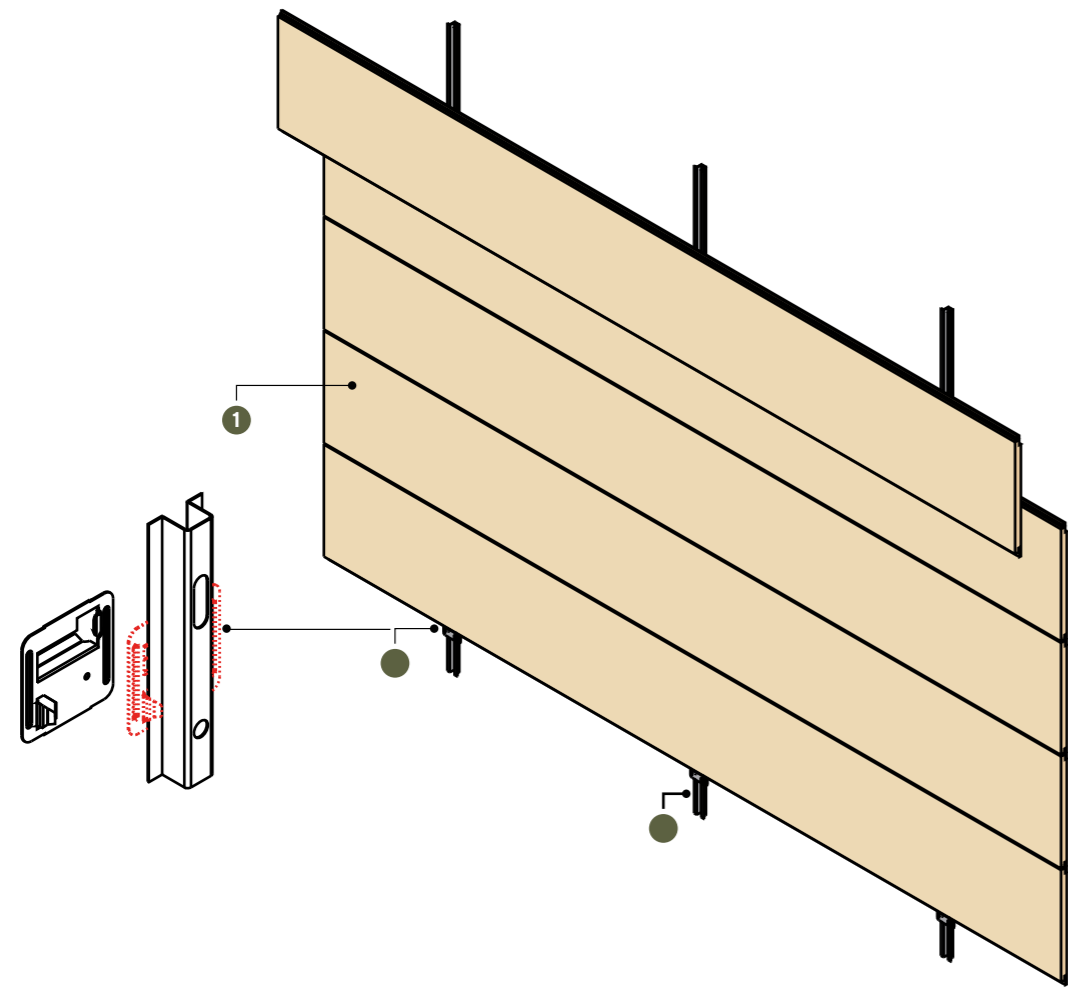

PANEL PANNELLO type

square quadrato
 rectangular rettangolare
 custom su progetto

SOLID WOOD

GRID SYSTEM STRUTTURA

· WC2

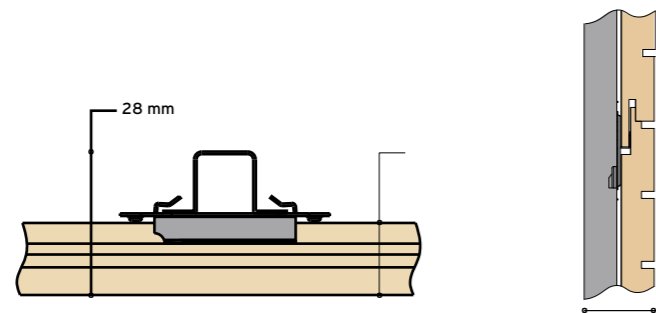

1

panel
 pannello

SP76

hidden suspension hook

SOLID WOOD COVERING 504 SYSTEM



100%

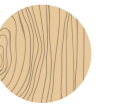

SOLID WOOD

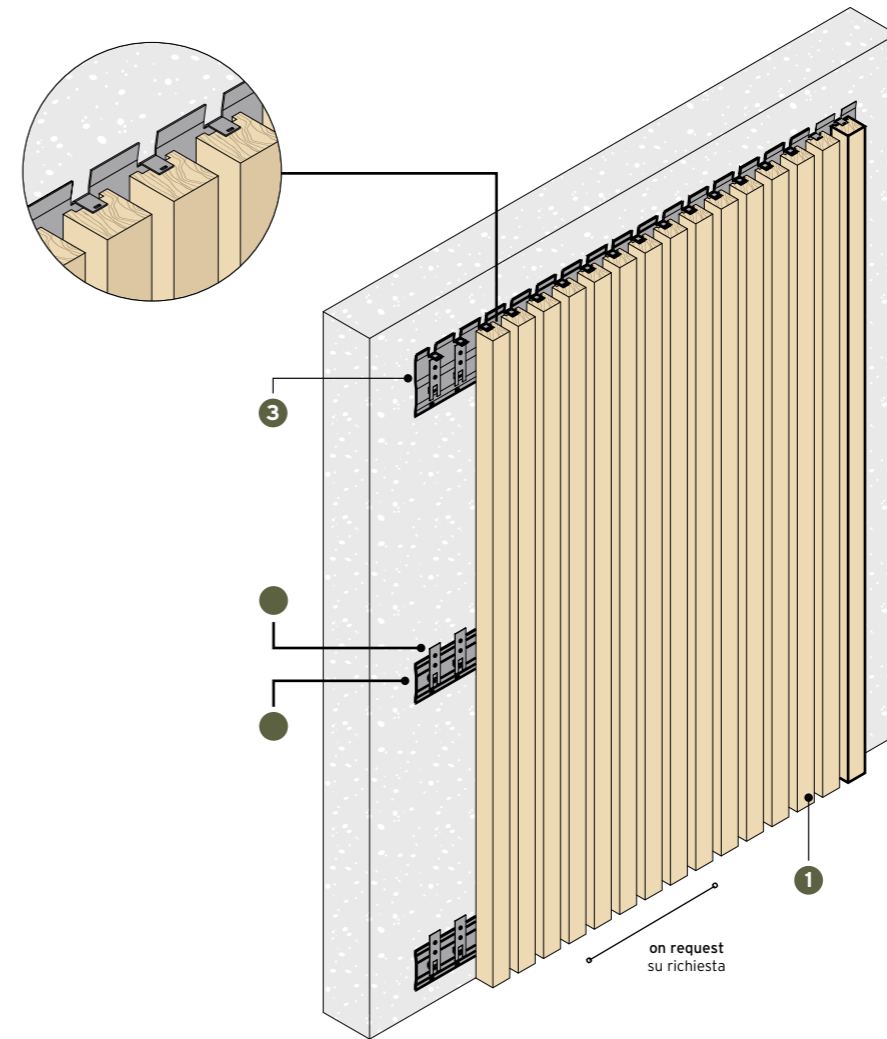

SLAT LAMELLA

dimension
 H 40/50/60 mm
 L 32/40 mm

type
 SOLID WOOD

GRID SYSTEM STRUTTURA

· CWF

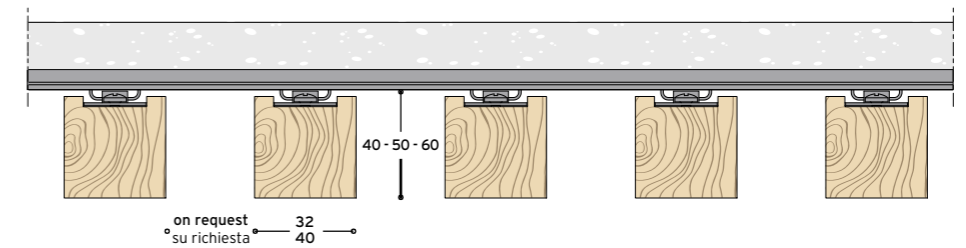

1

slat
 lamella
 H 40/50/60 mm

2

T 93/N main runner
 profilo portante
 85x4000 mm

3

T 93C/N closing profile
 profilo di chiusura
 85x4000 mm

4

SP83 connector for slat
 connettore per lamella

MODULARITY MODULARITÀ

SUSPENDED CEILINGS CONTROSOFFITTI

SHERWOOD ACOUSTIK PLUS
rectangular rettangolare

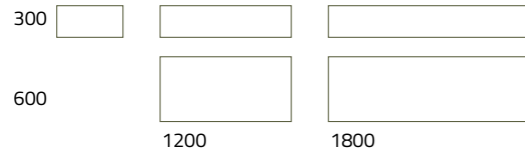

SHERWOOD ACOUSTIK PLUS
square quadrato

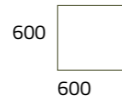

SOUND WOOD

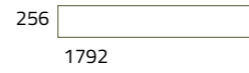

WALL CLADDINGS CONTROPARETE

SHERWOOD ACOUSTIK PLUS
rectangular rettangolare

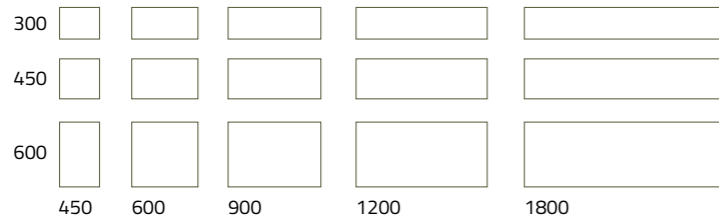

SHERWOOD ACOUSTIK PLUS
square quadrato

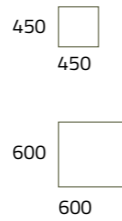

SOUND WOOD

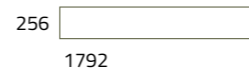

LAMELLA

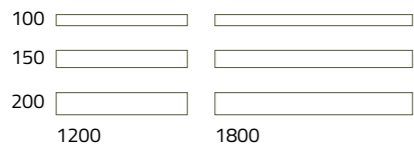

sample compositions · esempi di composizioni

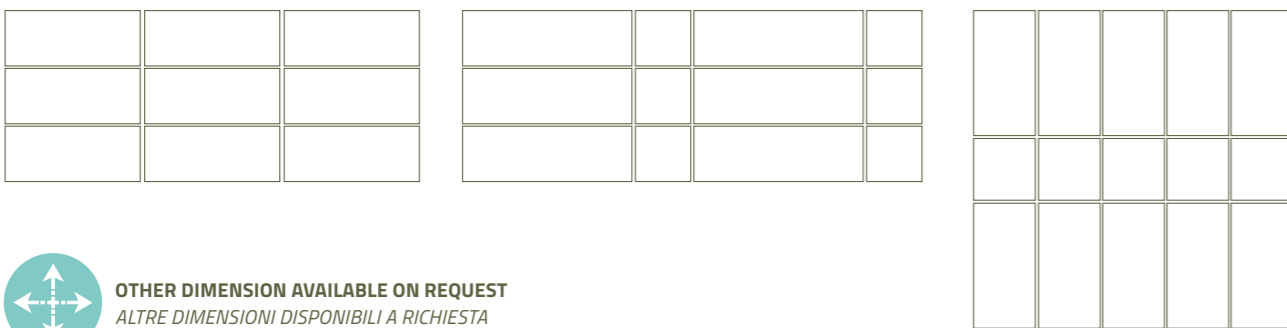
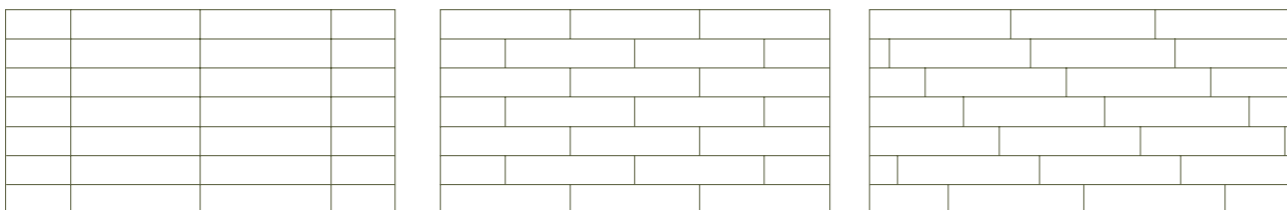

 OTHER DIMENSION AVAILABLE ON REQUEST
ALTRE DIMENSIONI DISPONIBILI A RICHIESTA

PERIMETRAL MOLDING CORNICI PERIMETRALI

WOOD EXPO 100

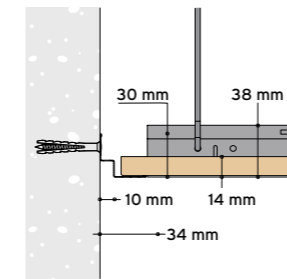

W3000
CWT

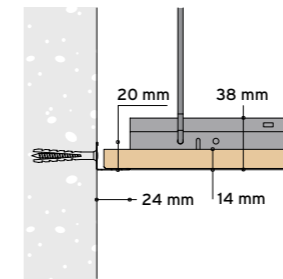

A3000
CWT

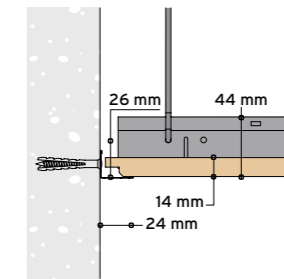

A3001
CWR · CWN

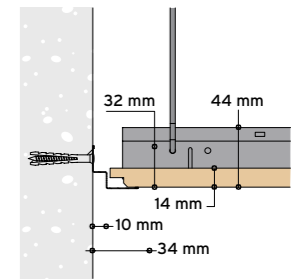

W3001
CWR · CWN

WOOD CONCEALED 200 SYSTEM

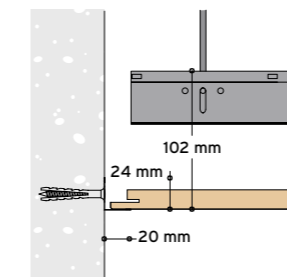

A3000
CWI

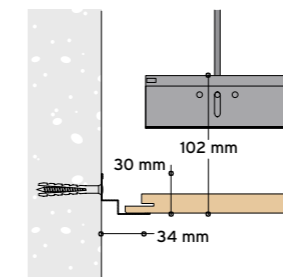

W3000
CWI

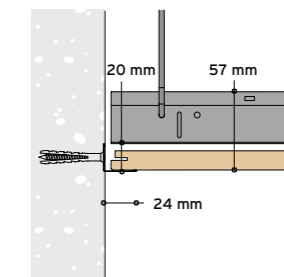

A3001
CWA

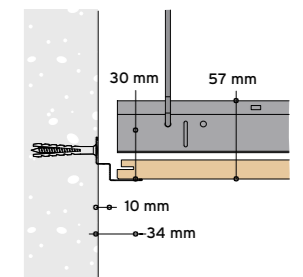

W3000
CWA

WOOD CONCEALED 400 / 401 SYSTEM

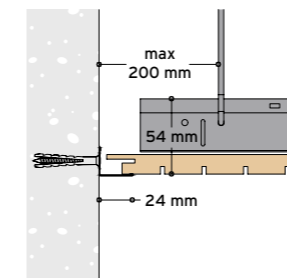

CWB · CWC
A3001

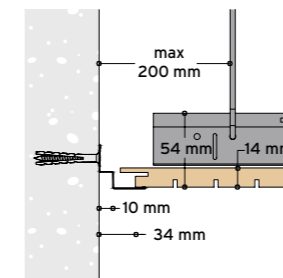

CWB · CWC
W3000

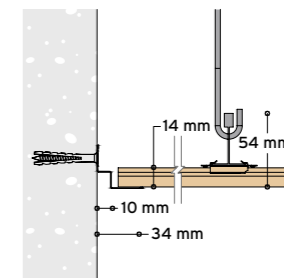

CWB · CWC
W3000

WOOD COVERING 500 / 501 / 502 / 503 SYSTEM

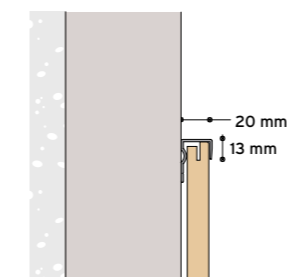

WC1 · WC2 · WC6 · WC7
PP1002 · PP1003

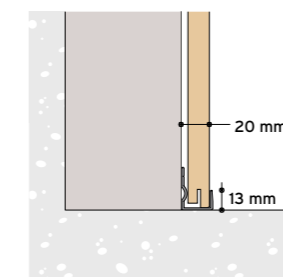

WC1 · WC2 · WC6 · WC7
PP1002 · PP1003

CORNERS ANGOLI

INTERNAL CORNER ANGOLO INTERNO

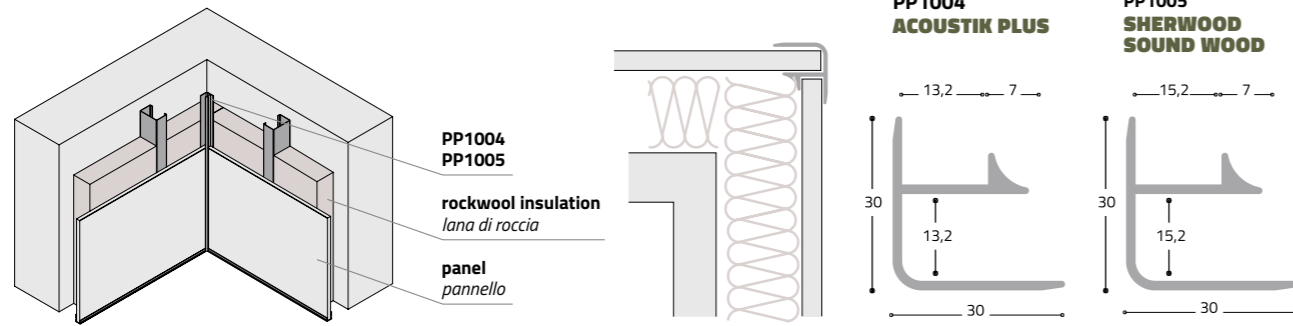

EXTERNAL CORNER ANGOLO ESTERNO

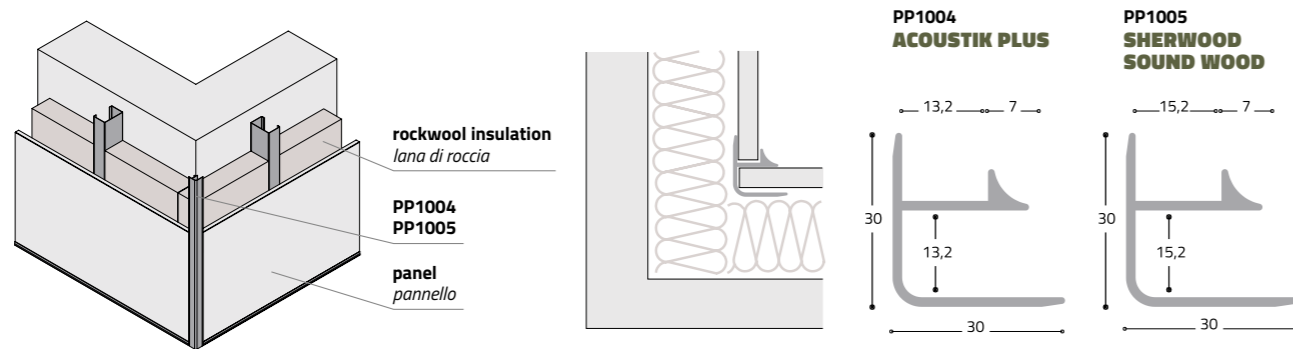

WOODEN CORNER ANGOLO IN LEGNO

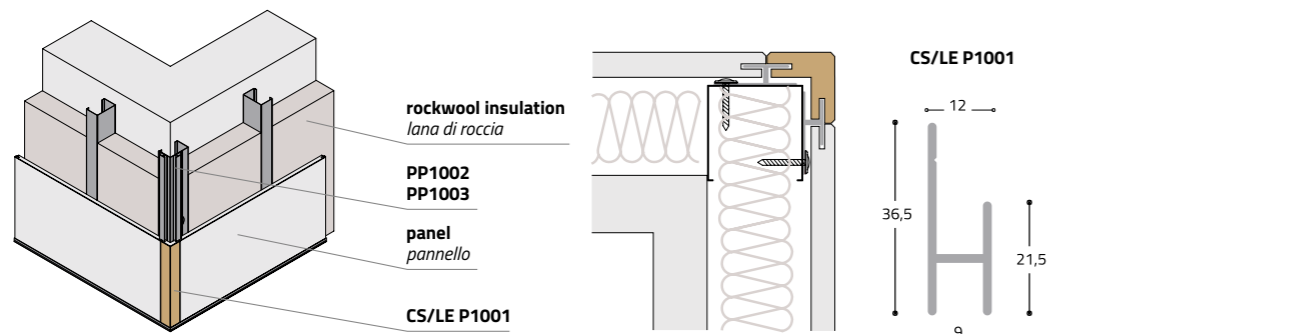

PROFILES PROFILI

LINEAR PROFILE PROFILO LINEARE

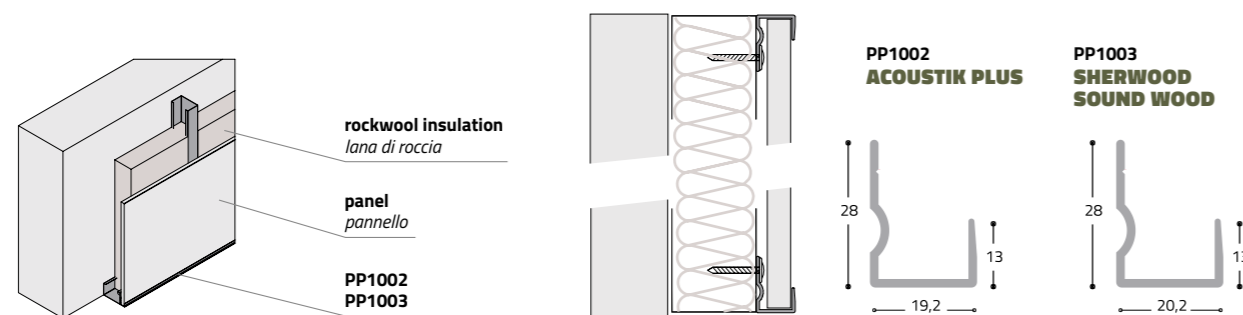

PERFORATION FORATURE



- no perforation *liscio*
- perforation *foratura*
- perforation *foratura*
- ▬ slots *asolatura*

ABC = SHERWOOD · ABC = ACOUSTIK PLUS

	F00 · PRO		F01 · PR1 Ø 6 = 2.27 % Ø 8 = 4.03 % ● : 289		F02 · PR2 Ø 6 = 4.28 % Ø 8 = 7.61 % ● : 545
	F03 · PR6 Ø 6 = 1.07 % Ø 8 = 1.90 % ● : 136		F04 · PR3 Ø 6 = 4.28 % Ø 8 = 7.61 % ● : 545		F05 · PR4 Ø 6 = 2.01 % Ø 8 = 3.57 % ● : 256
	F06 · PR8 Ø 6 = 1.20 % Ø 8 = 2.14 % ● : 153		F07 · PR7 Ø 6 = 2.27 % Ø 8 = 4.03 % ● : 289		F08 · PR5 Ø 6 = 10.17 % Ø 8 = 18.09 % ● : 1296
	F09 · PR9 Ø 3 = 2.55 % ● : 1296		A01 · SL1 6x66 mm - 11.00 % 8x66 mm - 14.57 % ▬ : 102		A02 · SL2 6x60 mm - 9.39 % 8x60 mm - 12.43 % ▬ : 96
	A03 · SL5 6x66 mm - 10.35 % 8x66 mm - 13.71 % ▬ : 96		A04 · SL6 6x66 mm - 5.18 % 8x66 mm - 6.86 % ▬ : 48		A05 · SL7 6x66 mm - 7.33 % 8x66 mm - 9.71 % ▬ : 68



ACOUSTIC ABSORPTION PANELS
ASSORBIMENTO ACUSTICO PANNELLI

test: Istituto Giordano n° 196088
197140 UNI EN ISO 354: 2003

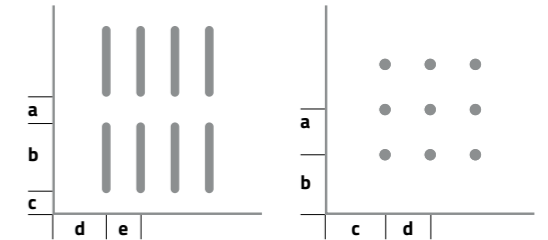

<p>A06 · SL3</p> <p>6x96 mm - 15.79 % 8x96 mm - 20.95 %</p> <p>— : 100</p>	<p>A07 · SL4</p> <p>6x60 mm - 19.37 % 8x60 mm - 25.64 %</p> <p>— : 198</p>	<p>A08 · AD8</p> <p>20x20 mm = 9.00 %</p> <p>■ : 81</p>
<p>A09</p> <p>50x50 mm = 56.25 %</p> <p>■ : 100</p>	<p>A010</p> <p>40x40 mm = 21.77 %</p> <p>■ : 198</p>	<p>A11</p> <p>spacing larghezza 3 mm depth profondità 2 mm</p> <p>30 mm</p>

ABC = SHERWOOD · ABC = ACOUSTIK PLUS

<p>F00 · DFO</p> <p>280 x 1200 mm 280 x 1500 mm 280 x 1800 x 14 mm 280 x 2100 x 14 mm</p>	<p>F01 · DF1</p> <table border="0"> <tr> <td>∅ 6</td> <td>∅ 8</td> <td></td> <td></td> </tr> <tr> <td>2.49%</td> <td>4.43%</td> <td>280 x 1200 mm</td> <td>● : 296</td> </tr> <tr> <td>2.48%</td> <td>4.40%</td> <td>280 x 1500 mm</td> <td>● : 368</td> </tr> <tr> <td>2.47%</td> <td>4.39%</td> <td>280 x 1800 mm</td> <td>● : 440</td> </tr> <tr> <td>2.50%</td> <td>4.44%</td> <td>280 x 2100 mm</td> <td>● : 520</td> </tr> </table>	∅ 6	∅ 8			2.49%	4.43%	280 x 1200 mm	● : 296	2.48%	4.40%	280 x 1500 mm	● : 368	2.47%	4.39%	280 x 1800 mm	● : 440	2.50%	4.44%	280 x 2100 mm	● : 520	<p>F02 · DF2</p> <table border="0"> <tr> <td>∅ 6</td> <td>∅ 8</td> <td></td> <td></td> </tr> <tr> <td>4.61%</td> <td>8.19%</td> <td>280 x 1200 mm</td> <td>● : 548</td> </tr> <tr> <td>4.60%</td> <td>8.17%</td> <td>280 x 1500 mm</td> <td>● : 683</td> </tr> <tr> <td>4.63%</td> <td>8.22%</td> <td>280 x 1800 mm</td> <td>● : 825</td> </tr> <tr> <td>4.65%</td> <td>8.27%</td> <td>280 x 2100 mm</td> <td>● : 968</td> </tr> </table>	∅ 6	∅ 8			4.61%	8.19%	280 x 1200 mm	● : 548	4.60%	8.17%	280 x 1500 mm	● : 683	4.63%	8.22%	280 x 1800 mm	● : 825	4.65%	8.27%	280 x 2100 mm	● : 968																				
∅ 6	∅ 8																																																													
2.49%	4.43%	280 x 1200 mm	● : 296																																																											
2.48%	4.40%	280 x 1500 mm	● : 368																																																											
2.47%	4.39%	280 x 1800 mm	● : 440																																																											
2.50%	4.44%	280 x 2100 mm	● : 520																																																											
∅ 6	∅ 8																																																													
4.61%	8.19%	280 x 1200 mm	● : 548																																																											
4.60%	8.17%	280 x 1500 mm	● : 683																																																											
4.63%	8.22%	280 x 1800 mm	● : 825																																																											
4.65%	8.27%	280 x 2100 mm	● : 968																																																											
<p>F03 · DF3</p> <table border="0"> <tr> <td>∅ 6</td> <td>∅ 8</td> <td></td> <td></td> </tr> <tr> <td>1.82%</td> <td>3.23%</td> <td>280 x 1200 mm</td> <td>● : 216</td> </tr> <tr> <td>1.94%</td> <td>3.45%</td> <td>280 x 1500 mm</td> <td>● : 288</td> </tr> <tr> <td>1.88%</td> <td>3.35%</td> <td>280 x 1800 mm</td> <td>● : 336</td> </tr> <tr> <td>1.85%</td> <td>3.28%</td> <td>280 x 2100 mm</td> <td>● : 384</td> </tr> </table>	∅ 6	∅ 8			1.82%	3.23%	280 x 1200 mm	● : 216	1.94%	3.45%	280 x 1500 mm	● : 288	1.88%	3.35%	280 x 1800 mm	● : 336	1.85%	3.28%	280 x 2100 mm	● : 384	<p>A01 · CD1</p> <table border="0"> <tr> <td>6x66</td> <td>8x66 mm</td> <td></td> <td></td> </tr> <tr> <td>12.83%</td> <td>16.99%</td> <td>280 x 1200 mm</td> <td>■ : 111</td> </tr> <tr> <td>12.76%</td> <td>16.90%</td> <td>280 x 1500 mm</td> <td>■ : 138</td> </tr> <tr> <td>12.71%</td> <td>16.84%</td> <td>280 x 1800 mm</td> <td>■ : 165</td> </tr> <tr> <td>12.88%</td> <td>17.05%</td> <td>280 x 2100 mm</td> <td>■ : 195</td> </tr> </table>	6x66	8x66 mm			12.83%	16.99%	280 x 1200 mm	■ : 111	12.76%	16.90%	280 x 1500 mm	■ : 138	12.71%	16.84%	280 x 1800 mm	■ : 165	12.88%	17.05%	280 x 2100 mm	■ : 195	<p>A02 · CD2</p> <table border="0"> <tr> <td>6x66</td> <td>8x66 mm</td> <td></td> <td></td> </tr> <tr> <td>9.36%</td> <td>12.40%</td> <td>280 x 1200 mm</td> <td>■ : 81</td> </tr> <tr> <td>9.98%</td> <td>13.22%</td> <td>280 x 1500 mm</td> <td>■ : 108</td> </tr> <tr> <td>9.71%</td> <td>12.86%</td> <td>280 x 1800 mm</td> <td>■ : 126</td> </tr> <tr> <td>9.51%</td> <td>12.59%</td> <td>280 x 2100 mm</td> <td>■ : 144</td> </tr> </table>	6x66	8x66 mm			9.36%	12.40%	280 x 1200 mm	■ : 81	9.98%	13.22%	280 x 1500 mm	■ : 108	9.71%	12.86%	280 x 1800 mm	■ : 126	9.51%	12.59%	280 x 2100 mm	■ : 144
∅ 6	∅ 8																																																													
1.82%	3.23%	280 x 1200 mm	● : 216																																																											
1.94%	3.45%	280 x 1500 mm	● : 288																																																											
1.88%	3.35%	280 x 1800 mm	● : 336																																																											
1.85%	3.28%	280 x 2100 mm	● : 384																																																											
6x66	8x66 mm																																																													
12.83%	16.99%	280 x 1200 mm	■ : 111																																																											
12.76%	16.90%	280 x 1500 mm	■ : 138																																																											
12.71%	16.84%	280 x 1800 mm	■ : 165																																																											
12.88%	17.05%	280 x 2100 mm	■ : 195																																																											
6x66	8x66 mm																																																													
9.36%	12.40%	280 x 1200 mm	■ : 81																																																											
9.98%	13.22%	280 x 1500 mm	■ : 108																																																											
9.71%	12.86%	280 x 1800 mm	■ : 126																																																											
9.51%	12.59%	280 x 2100 mm	■ : 144																																																											

— ceiling controsoffitto
— covering rivestimento

SLOTS ASOLATURA

a = 32 mm ∅ 6 = 1.07 %
 b = 58 mm ∅ 8 = 1.90 %
 c = 46 mm
 d = 44 mm
 e = 32 mm

α_p 0,87 | 1,05 | 0,73 | 0,52 | 0,35 $\alpha_w = 0,50$
 0,8 | 0,81 | 0,69 | 0,47 | 0,34 $\alpha_w = 0,50$

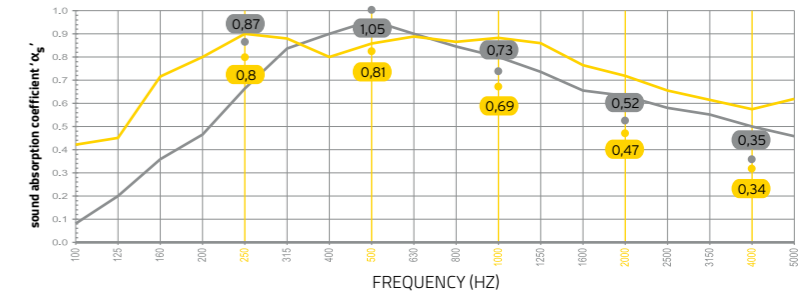

a = 38 mm
 b = 52 mm
 c = 49 mm
 d = 51 mm
 e = 16 mm

α_p 0,97 | 0,93 | 0,64 | 0,45 | 0,35 $\alpha_w = 0,50$
 0,77 | 0,78 | 0,62 | 0,41 | 0,39 $\alpha_w = 0,45$

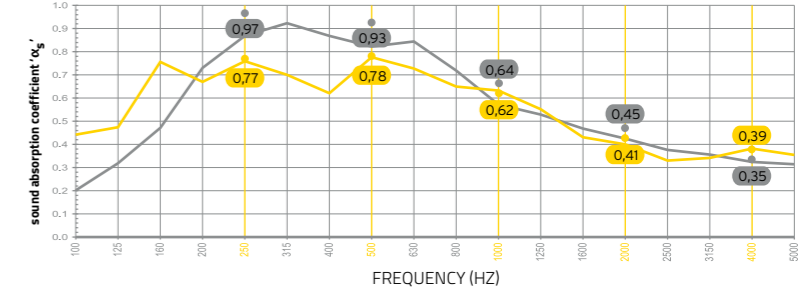

a = 52 mm
 b = 88 mm
 c = 46 mm
 d = 44 mm
 e = 16 mm

α_p 0,84 | 1,09 | 0,81 | 0,6 | 0,47 $\alpha_w = 0,60$
 0,89 | 0,84 | 0,83 | 0,6 | 0,55 $\alpha_w = 0,50$

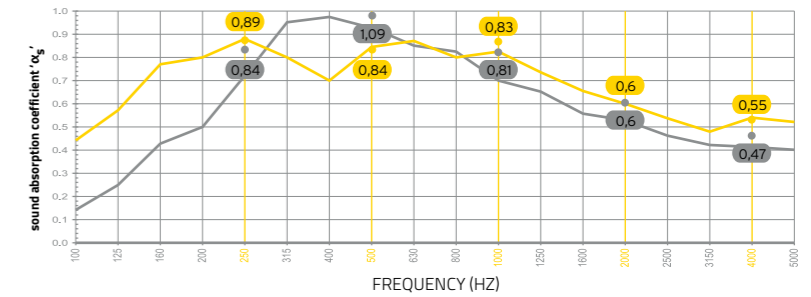

a = 32 mm
 b = 58 mm
 c = 46 mm
 d = 44 mm
 e = 16 mm

α_p 0,79 | 1,14 | 0,94 | 0,76 | 0,59 $\alpha_w = 0,75$
 0,91 | 0,86 | 0,88 | 0,71 | 0,59 $\alpha_w = 0,75$

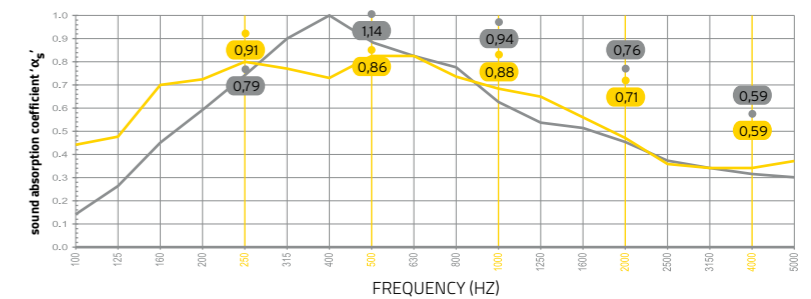

SMOOTH LISCIO



α_p	0,13	0,09	0,03	0,05	0,05	$\alpha_w = 0,10$
	0,06	0,07	0,05	0,02	0,02	$\alpha_w = 0,05$

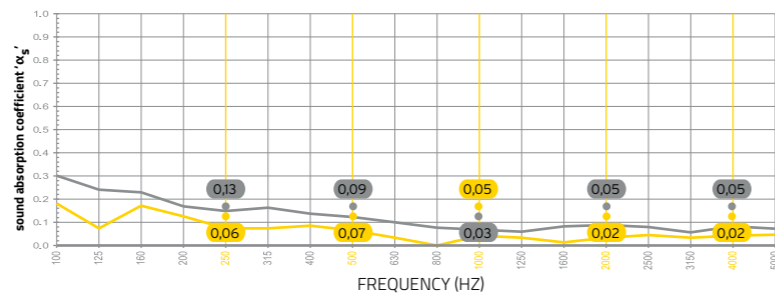

PERFORATION FORATURA

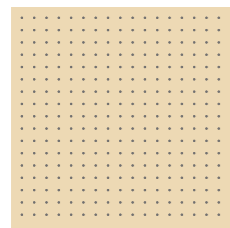

a = 32 mm
b = 44 mm
c = 44 mm
d = 32 mm

α_p	1,01	0,64	0,32	0,18	0,1	$\alpha_w = 0,20$
	0,67	0,57	0,3	0,15	0,13	$\alpha_w = 0,25$

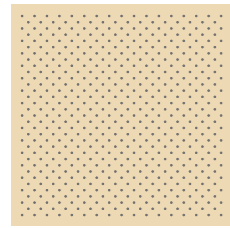
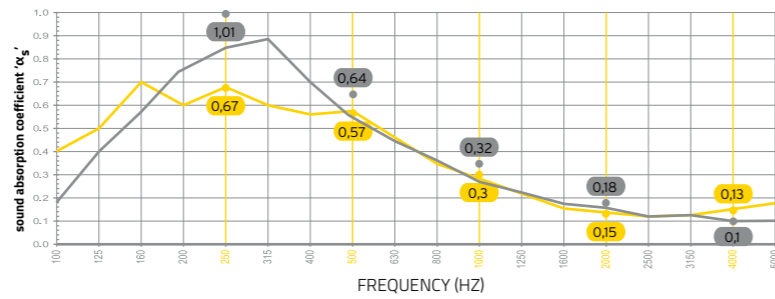

a = 16 mm
b = 44 mm
c = 44 mm
d = 16 mm

α_p	0,99	0,94	0,55	0,32	0,2	$\alpha_w = 0,35$
	0,8	0,78	0,54	0,29	0,19	$\alpha_w = 0,35$

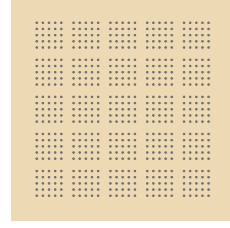
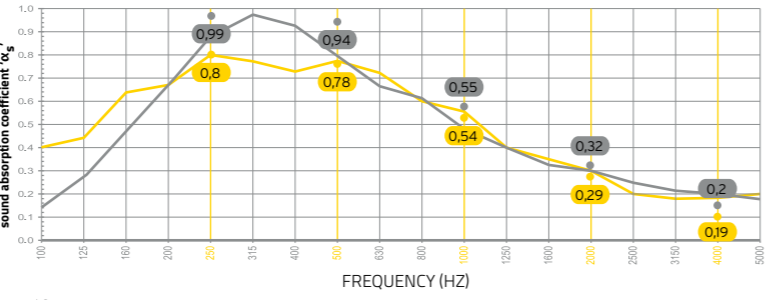

a = 16 mm
b = 76 mm
c = 76 mm
d = 16 mm

α_p	1	0,88	0,59	0,37	0,2	$\alpha_w = 0,35$
	0,75	0,75	0,55	0,32	0,24	$\alpha_w = 0,35$

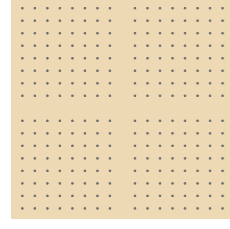
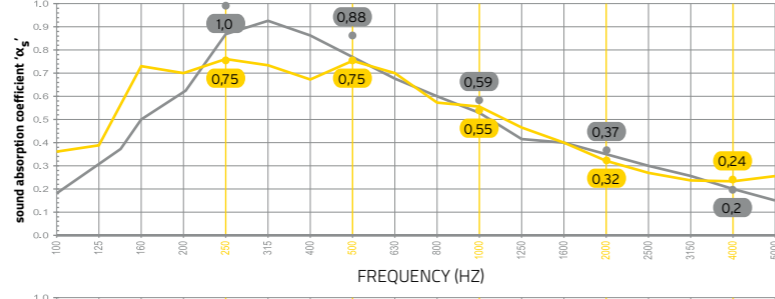

a = 32 mm
b = 44 mm
c = 44 mm
d = 32 mm

α_p	0,98	0,59	0,28	0,16	0,09	$\alpha_w = 0,20$
	0,61	0,56	0,3	0,16	0,15	$\alpha_w = 0,25$

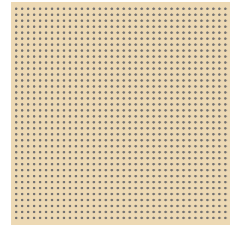
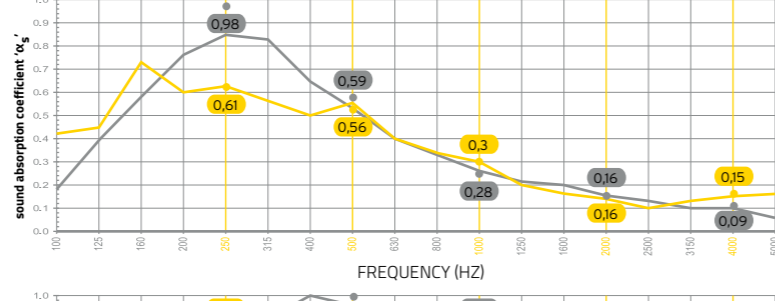

a = 16 mm
b = 17,5 mm
c = 17,5 mm
d = 16 mm

α_p	0,82	1,12	0,87	0,64	0,41	$\alpha_w = 0,60$
	0,88	0,91	0,84	0,63	0,46	$\alpha_w = 0,65$

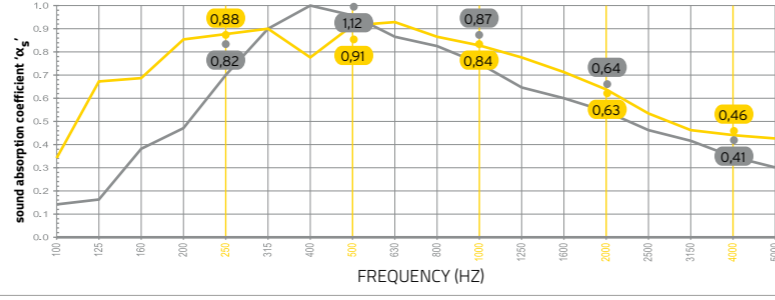

SOUND WOOD PERFORATION - ACOUSTIC ABSORPTION PANELS
FORATURE · ASSORBIMENTO ACUSTICO



Each element incorporate a layer of sound absorbing material on the panelbacking.
Ogni elemento è comprensivo di uno strato di materiale fonoassorbente sul retro.

ceiling *controsoffitto*
covering *rivestimento*

Istituto Giordano n° 196088
197140 UNI EN ISO 354: 2003

SUPREME SOUND WOOD 1616

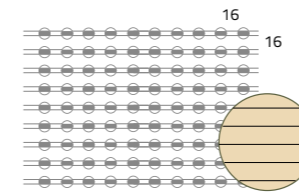

hz	250	500	1000	2000	4000	$\alpha_w = 0,75$
α_p	0,80	0,85	0,90	0,80	0,55	$\alpha_w = 0,85$
	0,75	1,00	0,95	0,80	0,70	

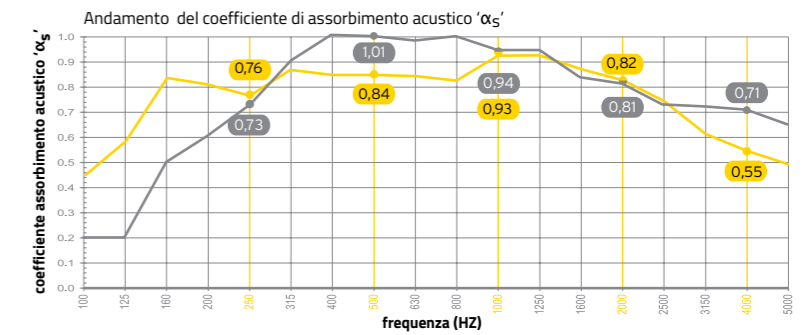

HIGH SOUND WOOD 3216

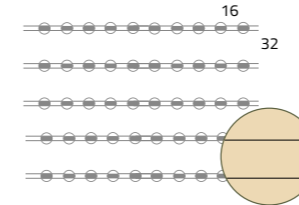

hz	250	500	1000	2000	4000	$\alpha_w = 0,50$
α_p	0,70	0,75	0,70	0,50	0,35	$\alpha_w = 0,55$
	0,80	0,90	0,75	0,50	0,40	

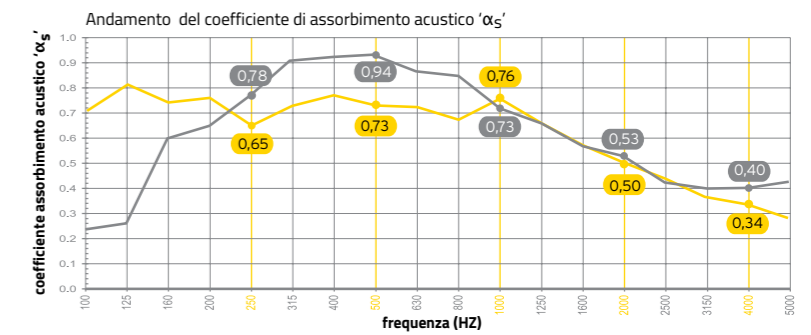

MEDIUM SOUND WOOD 1632

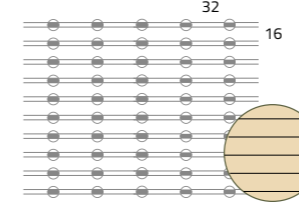

hz	250	500	1000	2000	4000	$\alpha_w = 0,45$
α_p	0,75	0,80	0,75	0,55	0,25	$\alpha_w = 0,65$
	0,80	0,95	0,80	0,60	0,50	

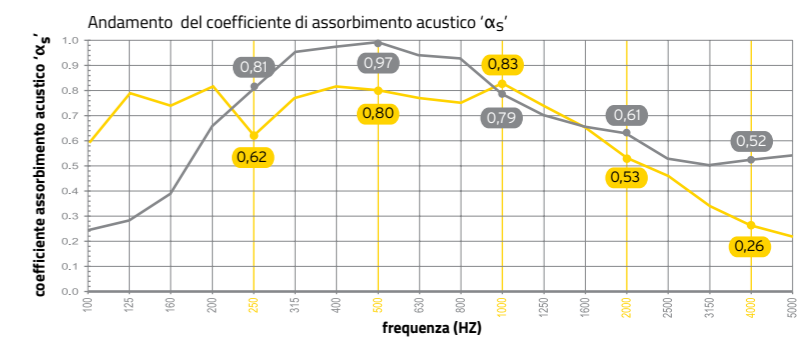

LIGHT SOUND WOOD 3232

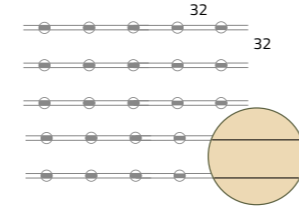

hz	250	500	1000	2000	4000	$\alpha_w = 0,30$
α_p	0,65	0,65	0,50	0,30	0,10	$\alpha_w = 0,40$
	0,70	0,70	0,50	0,30	0,30	

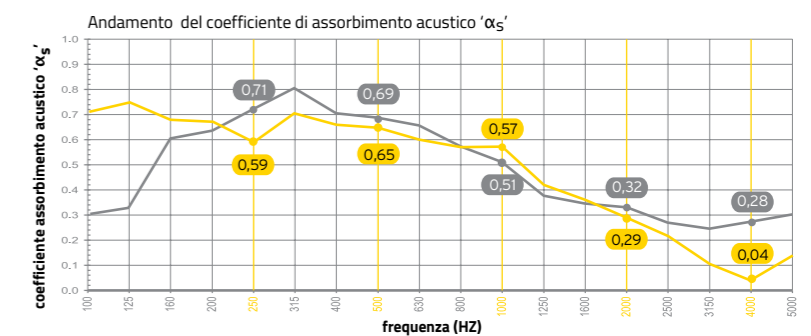

WOOD EXPO 100 SYSTEM

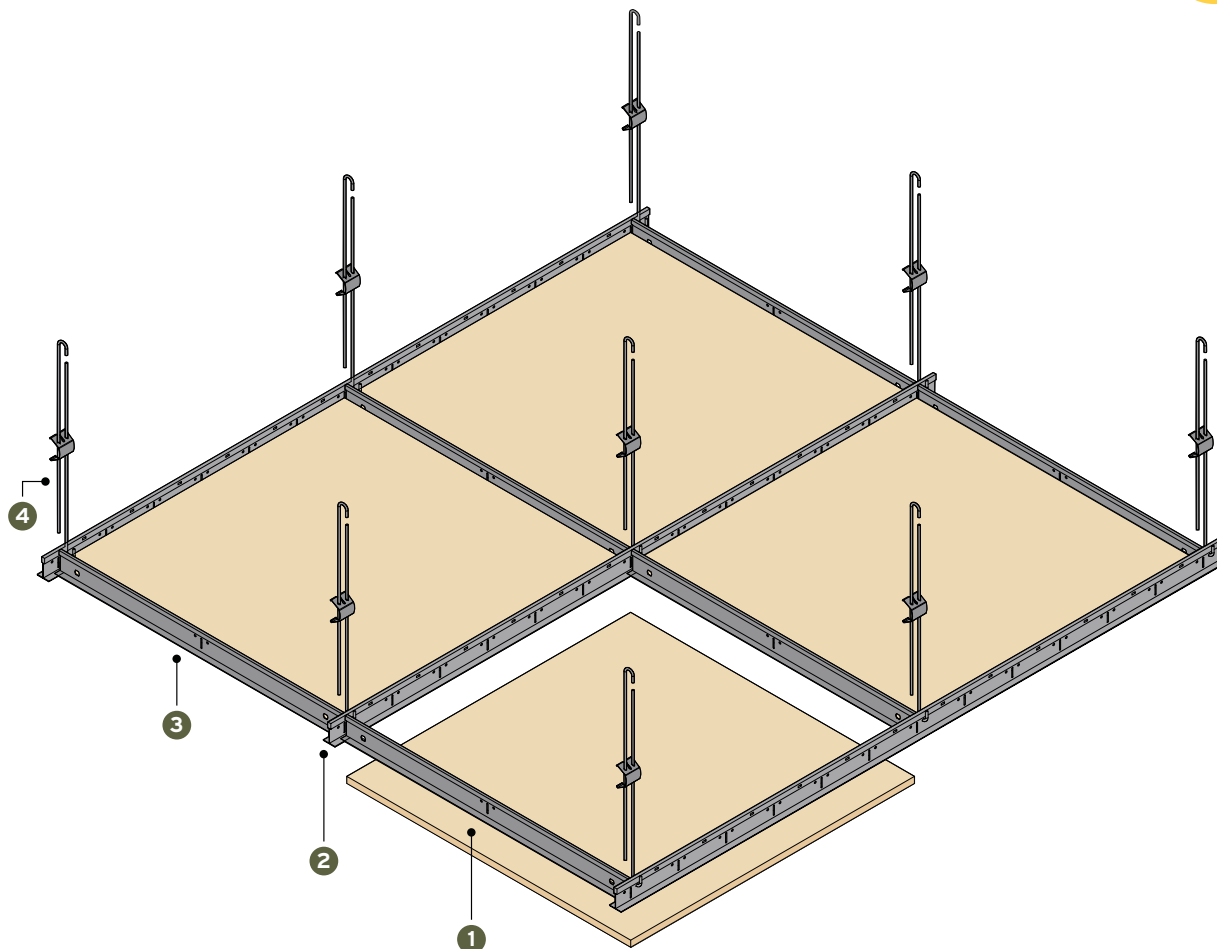

PANEL PANNELLO

dimension type
 square quadrato · MICRO PLUS 250
 rectangular rettangolare

GRID SYSTEM STRUTTURA

- CWT
- CWR
- CWN
- CWX

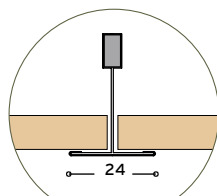

TRIM T24 > CWT

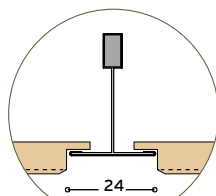

REVEAL T24 > CWR

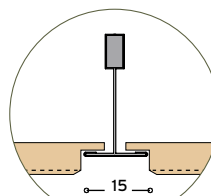

NARROW T15 > CWN

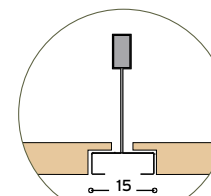

XLINE T15 > CWX

38

1

panel
 pannello
 600x600 mm
 600x1200 mm

2

main runner
 profilo portante

CWT · CWR > **PKH 3700** 24x38x3700 mm

CWN > **PKA 3700** 15x38x3700 mm

CWX > **BP 3600** 15x42x3600 mm

3

cross tee
 profilo intermedio

IKH 0600 24x38x600 mm

IKHA 0600 24x38x600 mm

BP 0600 15x42x600 mm

4

SOR suspension
 sospensione

WOOD CONCEALED 200 SYSTEM

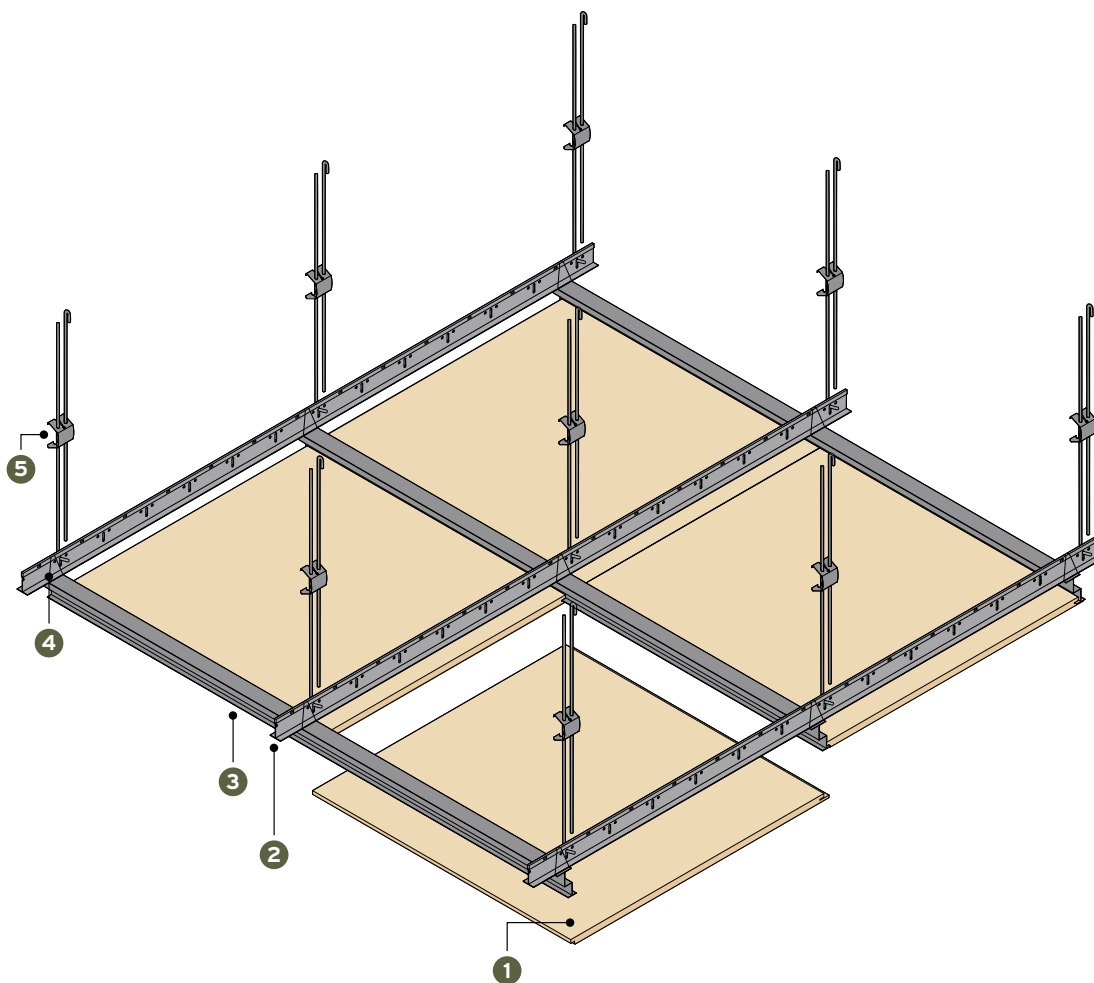

PANEL PANNELLO

dimension type
 square quadrato · MICRO PLUS 250
 rectangular rettangolare

GRID SYSTEM STRUTTURA

· CWI

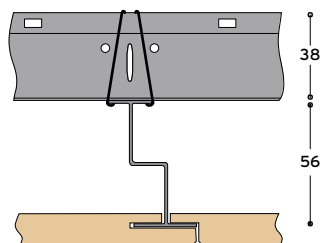

1	2	3	4	5
panel pannello 600x600 mm 600x1200 mm	P 3700 Z main runner profilo portante 24x38x3700 mm	Z 4000 W secondary profile profilo secondario 24x56x4000 mm	SP 38.1 cross connector raccordo ortogonale	SOR suspension sospensione

WOOD CONCEALED 200 SYSTEM **accessible**



**INSPECTABLE
WITH TRAPDOOR**
ISPEZIONABILE
CON BOTOLA

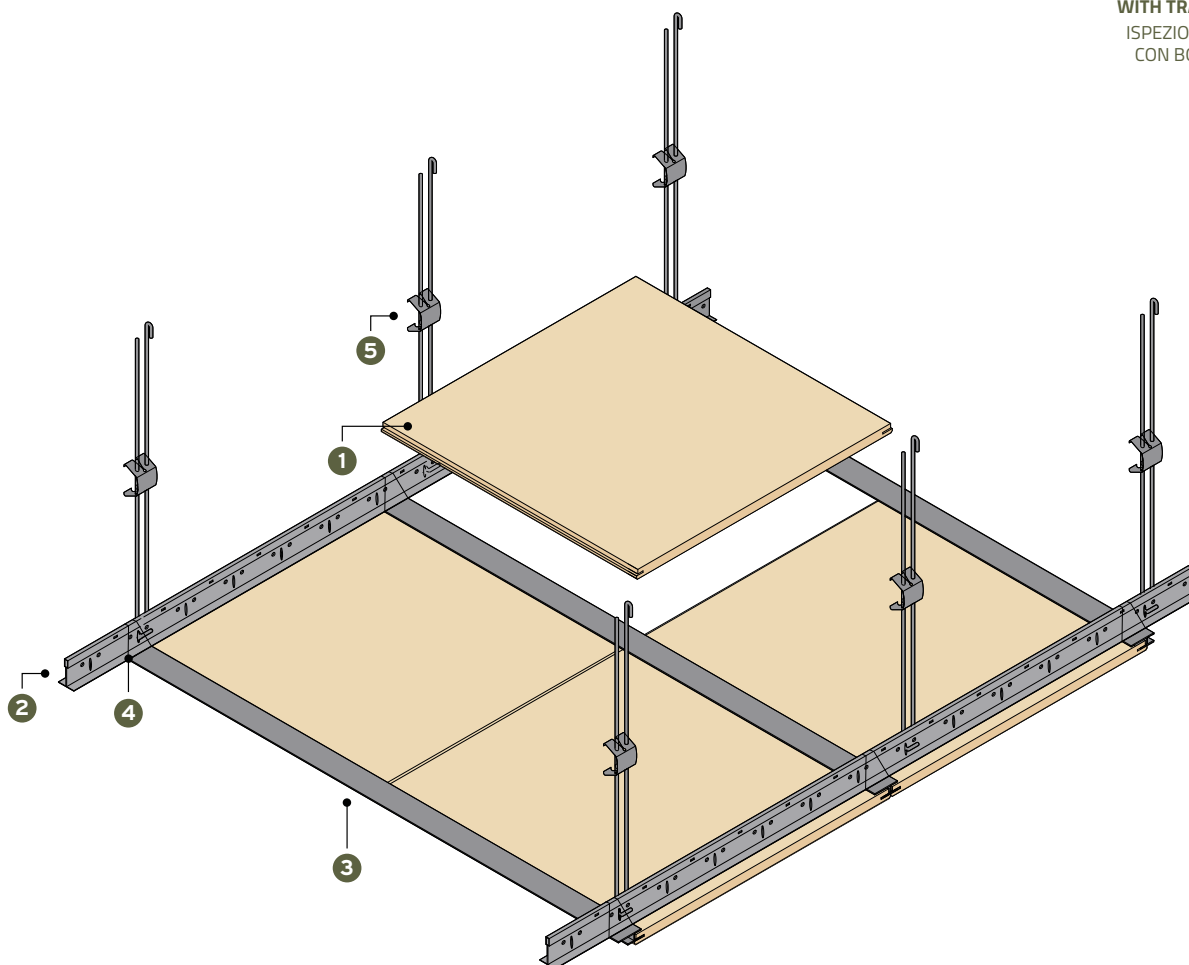

PANEL PANNELLO

dimension type
square quadrato · MICRO PLUS 250
rectangular rettangolare

GRID SYSTEM STRUTTURA

· CWA

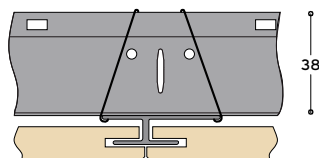

1

panel
pannello
600x600 mm
600x1200 mm

2

P 3700 Z main runner
profilo portante
24x38x3700 mm

3

PP 1001 secondary profile
profilo secondario
36,5x12x4000 mm

4

SP 38.1 cross connector
raccordo ortogonale

5

SOR suspension
sospensione

WOOD CONCEALED 200 CWI SYSTEM

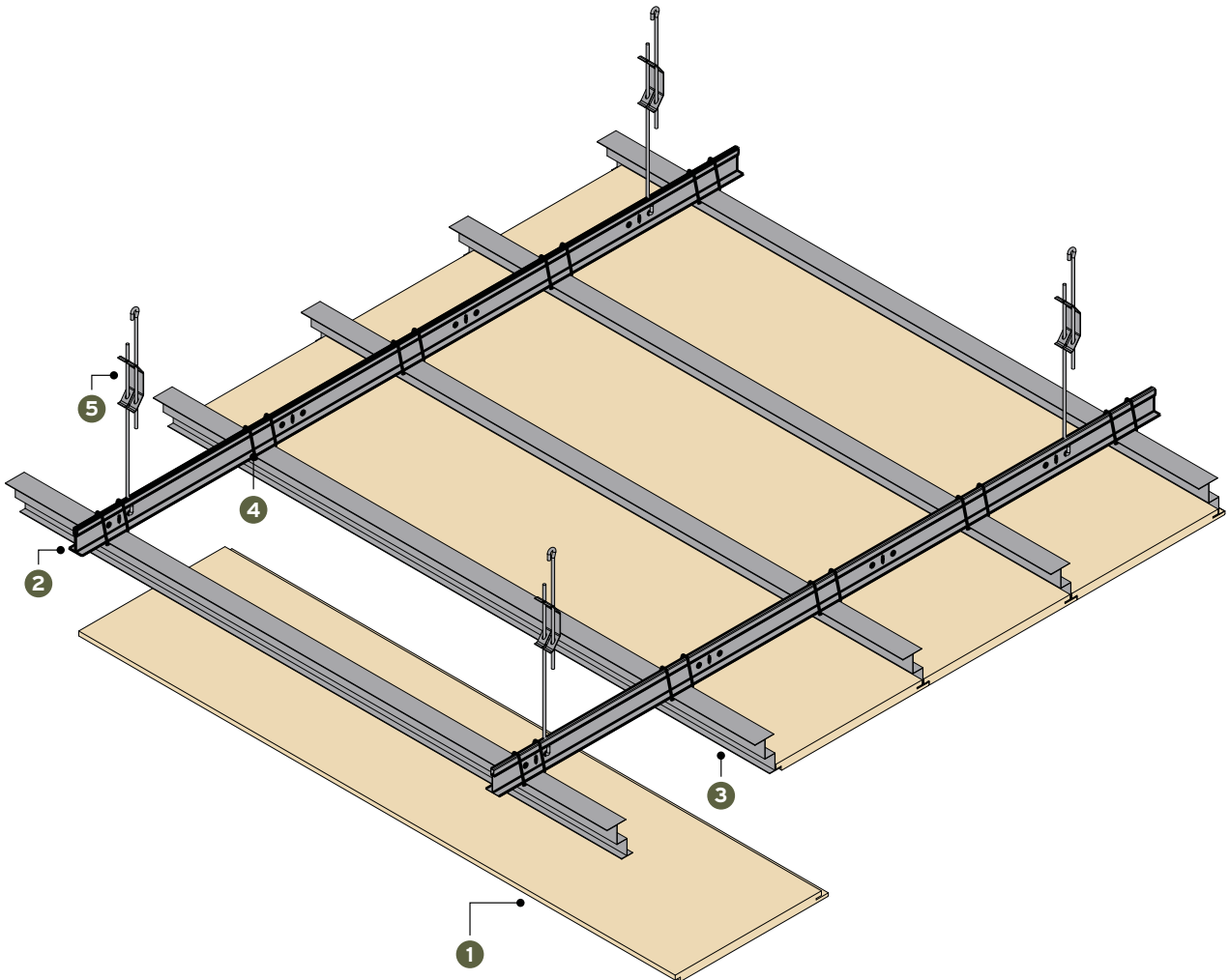

PANEL PANNELLO

dimension type
 square quadrato · MICRO PLUS 250
 rectangular rettangolare

GRID SYSTEM STRUTTURA

· CWI

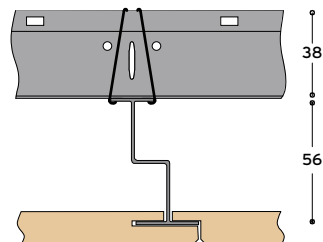

1	2	3	4	5
panel pannello 600x600/1200 256x1792	P 3700 Z main runner profilo portante 24x38x3700 mm	Z 4000 W secondary profile profilo secondario 36,5x12x4000 mm	SP 38.1 cross connector raccordo ortogonale	SOR suspension sospensione

WOOD CONCEALED 400 SYSTEM

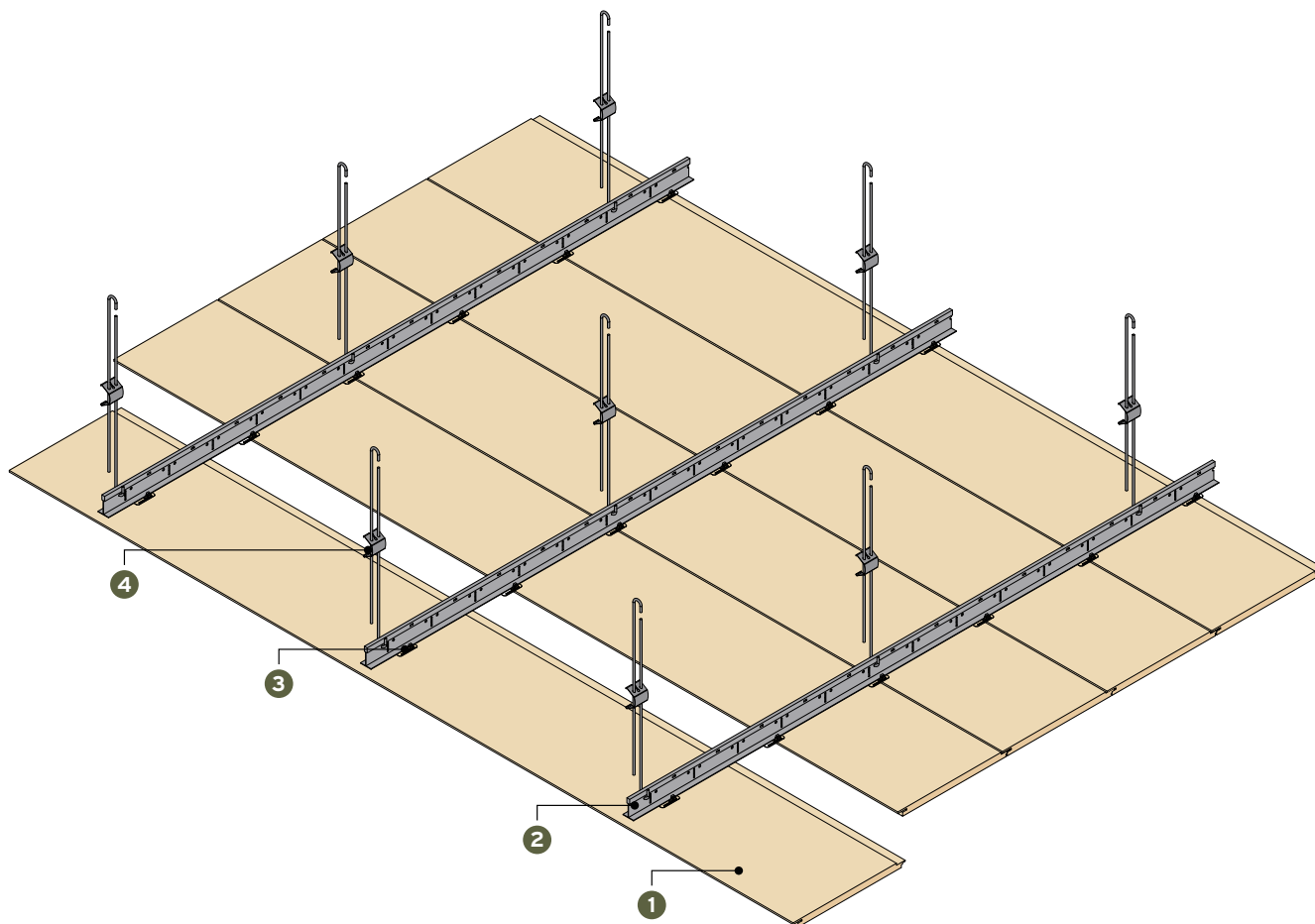

PANEL PANNELLO

dimension type
 rectangular rettangolare · MICRO PLUS 250

GRID SYSTEM STRUTTURA

· CWB

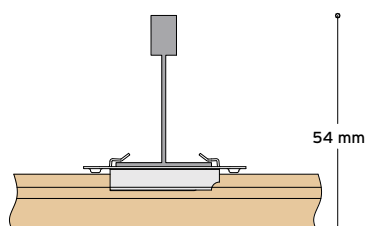

1

panel
 pannello

2

P 3700 Z main runner
 profilo portante
 24x38x3700 mm

3

SP76 hidden suspension hook
 gancio di sospensione nascosto

4

SOR suspension
 sospensione

WOOD CONCEALED 401 SYSTEM

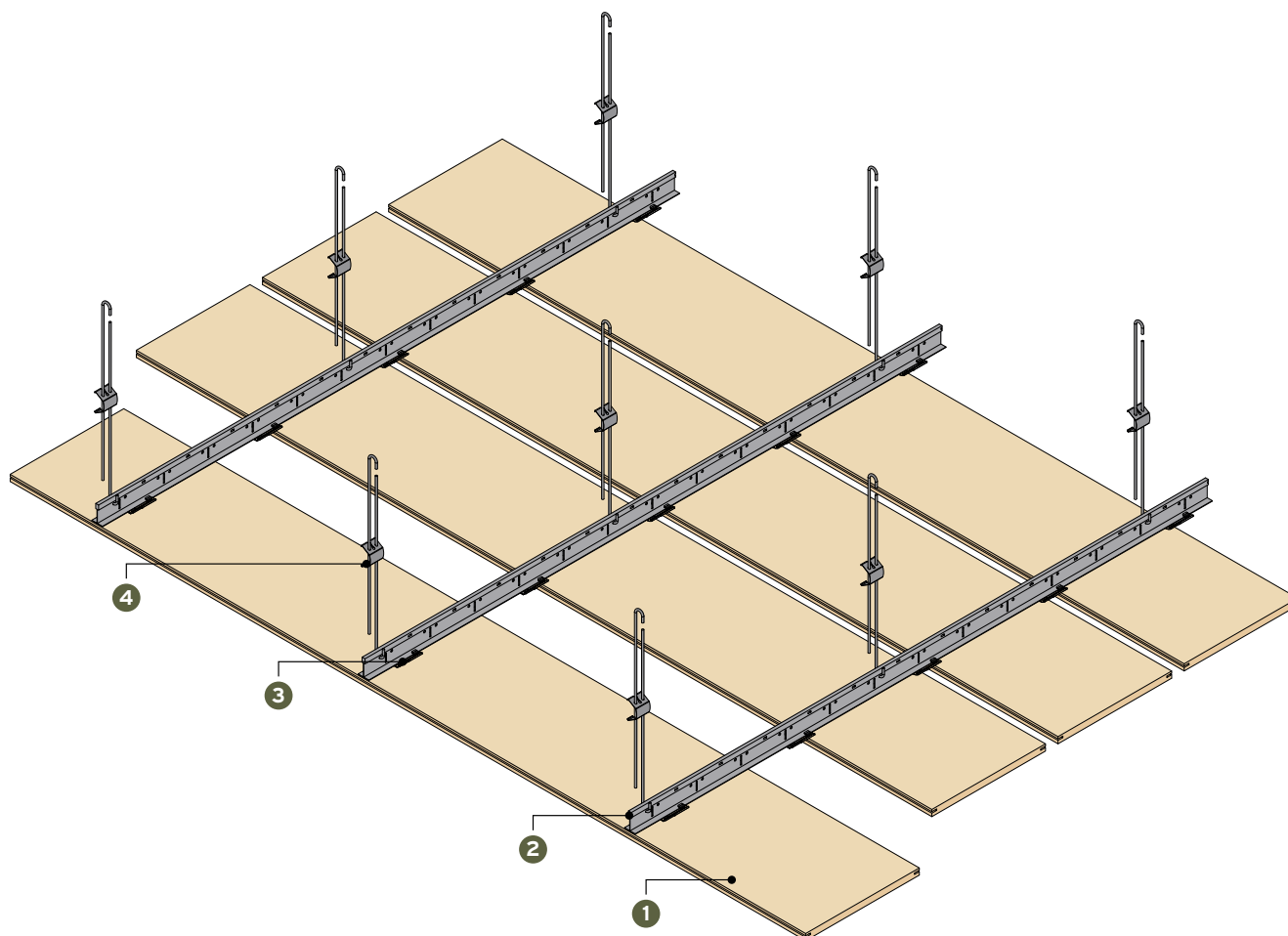

PANEL PANNELLO

dimension type
 rectangular rettangolare · MICRO PLUS 250

GRID SYSTEM STRUTTURA

· CWC

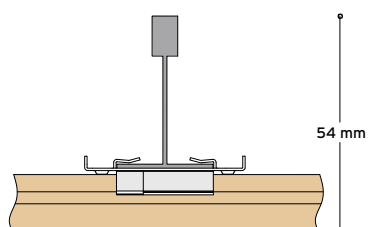

1	2	3	4
panel pannello	P 3700 Z main runner profilo portante 24x38x3700 mm	SP 78 spacer hook gancio distanziale gap fuga 20 mm	SOR suspension sospensione

WOOD COVERING 500 SYSTEM



EASY INSPECT



CUSTOM SIZE

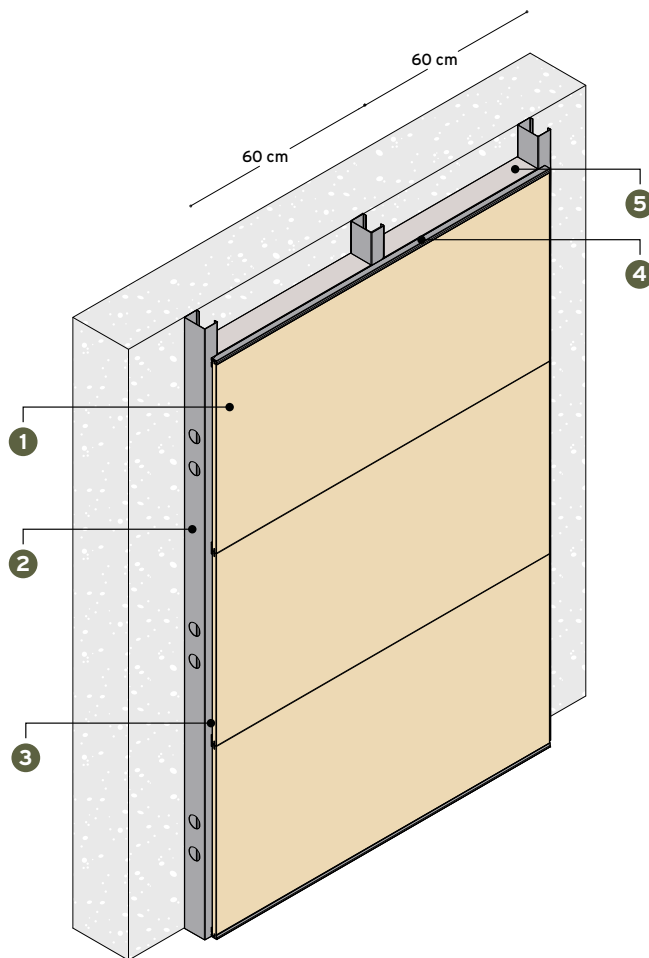

PANEL PANNELLO

dimension type
 square quadrato · MICRO PLUS 250
 rectangular rettangolare

custom su misura

GRID SYSTEM STRUTTURA

· WC1

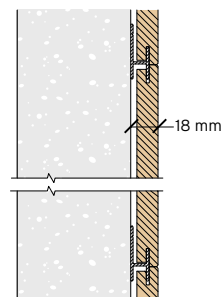
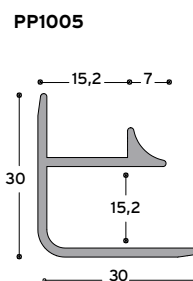
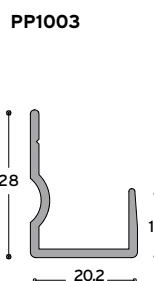
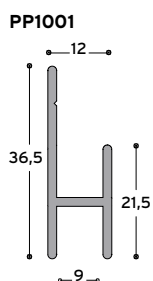

1

panel pannello

2

M46 / 75 primary support structure struttura di sostegno primaria

3

PP1001 Acoustik Plus Sherwood
PP1001.N Sound Wood secondary profile profilo secondario

4

PP1002 Acoustik Plus
PP1003 Sherwood Sound Wood starting profile profilo di partenza

5

PPN1 / 40.1 rockwool insulation lana di roccia 600 x 1200 mm

WOOD COVERING 501 SYSTEM



EASY INSPECT



CUSTOM SIZE

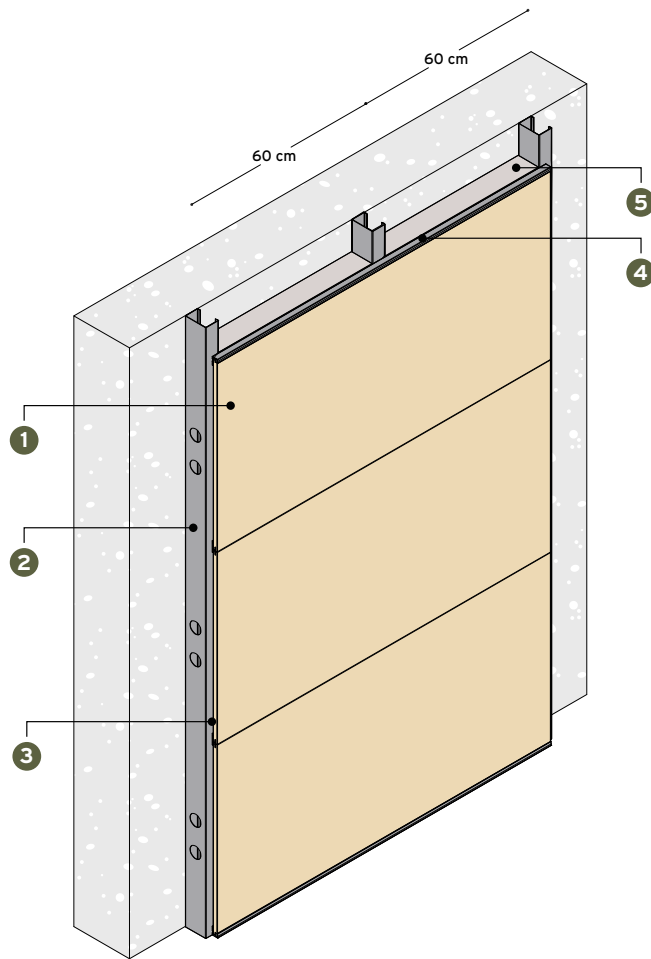

PANEL PANNELLO

dimension type
 square quadrato · MICRO PLUS 250
 rectangular rettangolare

custom su misura

GRID SYSTEM STRUTTURA

· WC6

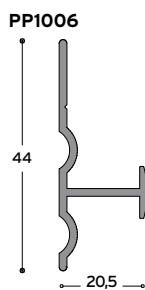

PP1003

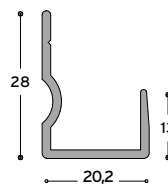

PP1005

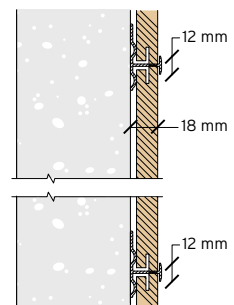
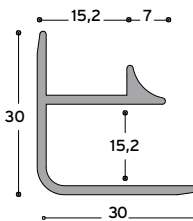

1

panel
 pannello

2

M46 / 75 primary support
 structure
 struttura di sostegno
 primaria

3

PP1006 secondary profile
 profilo secondario

4

PP1002 Acoustik Plus
PP1003 Sherwood Sound Wood
 starting profile
 profilo di partenza

5

PPN1 / 40.1 rockwool insulation
 lana di roccia
 600 x 1200 mm

WOOD COVERING 502 SYSTEM



EASY INSPECT



CUSTOM SIZE

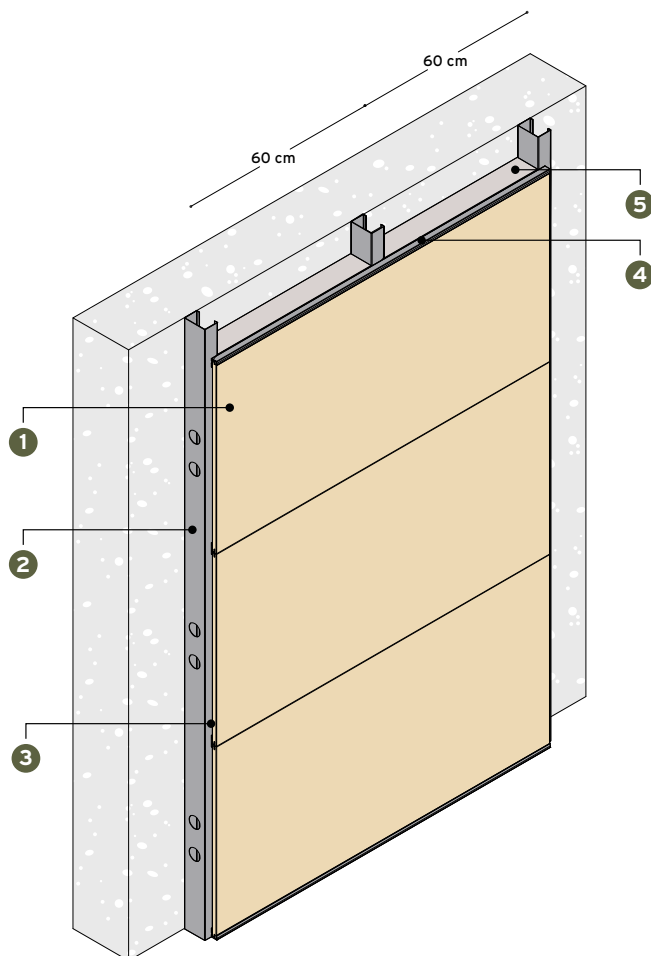

PANEL PANNELLO

dimension type
 square quadrato MICRO PLUS 250
 rectangular rettangolare

custom su misura

GRID SYSTEM STRUTTURA

· WC7

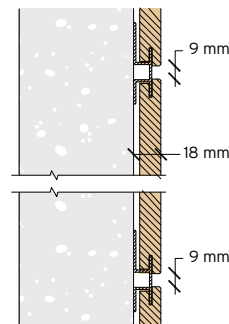
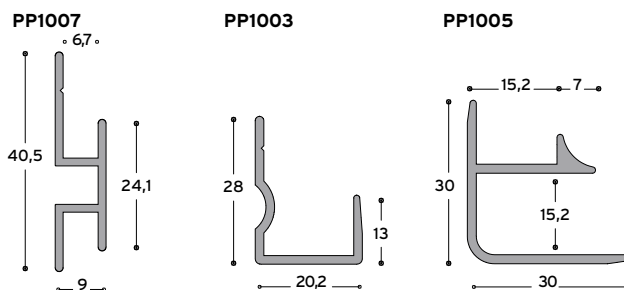

1

2

3

4

5

panel pannello

M46 / 75 primary support structure
 struttura di sostegno primaria

PP1007 secondary profile
 profilo secondario

PP1002 Acoustik Plus starting profile
 profilo di partenza
PP1003 Sherwood Sound Wood

PPN1 / 40.1 rockwool insulation
 lana di roccia
 600 x 1200 mm

WOOD COVERING 503 SYSTEM



EASY INSPECT



CUSTOM SIZE

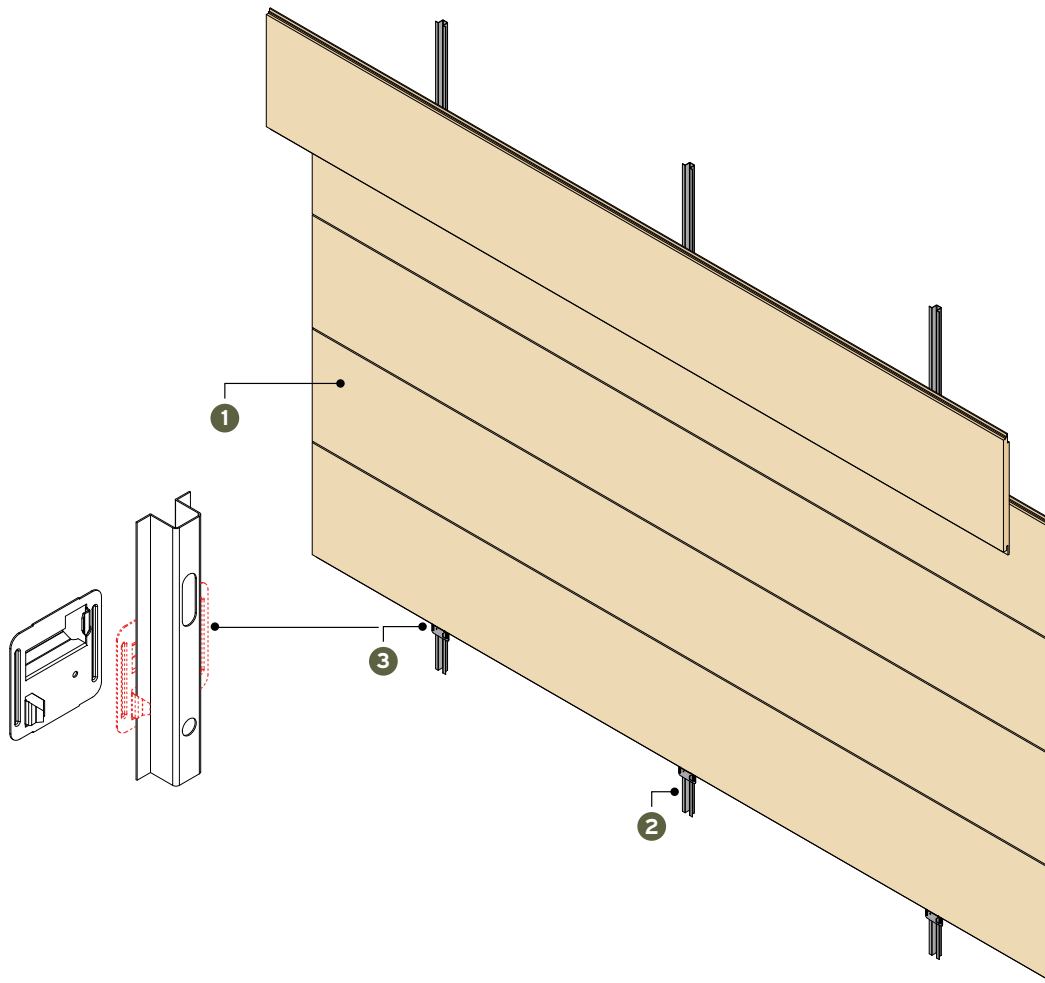

PANEL PANNELLO

dimension type
 square quadrato · MICRO PLUS 250
 rectangular rettangolare
 custom su progetto

GRID SYSTEM STRUTTURA

· WC2

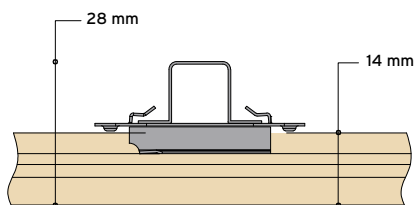

PP1003

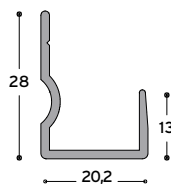

PP1005

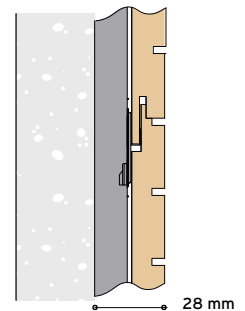
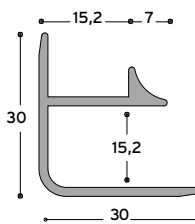

1

panel
 pannello

2

PP 1008

3

SP76 hidden suspension hook
 gancio di sospensione nascosto

FINITURE

NOBILITATO MELAMINICO

> MICRO PLUS 250 · SHERWOOD · SOUND WOOD · LAMELLA



rovere rock bianco



olmo tafira



rovere italia



rovere bruges



noce athens



bianco

IMPIALLACCIATO LEGNO

> MICRO PLUS 250 · SHERWOOD · ACOUSTIK PLUS · SOUND WOOD · LAMELLA

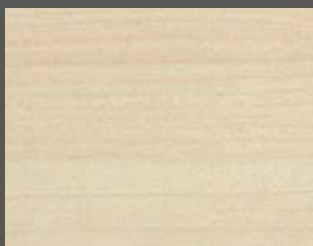

acero

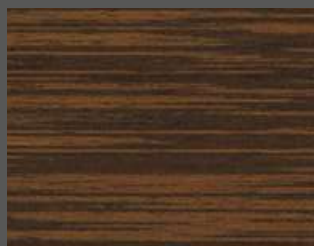

wengè



faggio



ciliegio



zebrano



frassino



noce 1



noce 2



mogano



rovere

Le cartelle colori riportate sono puramente indicative, e si raccomanda la richiesta di campionatura. Per colori non presenti in cartella e soltanto per forniture di

colore pari o superiori a 800 m², contattare l'ufficio tecnico. Gli accessori del sistema Wood possono essere in finitura alluminio o legno.

3.LCA Information

Functional Unit: 1 m² of ceiling/covering

Reference service life: 20 years

Time representativeness: primary data refer to 2021 year. Generic data are sector studies, national databases and specific documents for the sector under study.

Database(s) and LCA Software: Ecoinvent 3.8, SimaPro 9.3.0.3.

In accordance with the **reference PCR**, the life cycle of the product is "From cradle to grave" type and has been divided into three parts:

- **Upstream processes** (from cradle to gate)
- **Core processes** (gate to gate)
- **Downstream processes** (from gate to grave)

Phases excluded from the study are:

- installation phase (A5), because it is not managed by CBI Europe;
- use phase (B1, B2, B3, B4, B5, B6, B7), because it is not provided for ceilings.

3. Informazioni sullo studio LCA

Unità funzionale: 1 m² di controsoffitto/rivestimento

Vita media del controsoffitto: 20 anni

Rappresentatività dei dati: i dati primari sono relativi all'anno 2021. I dati generici sono studi di settore, database Nazionali e documenti specifici per il settore oggetto di studio.

Database e software di analisi utilizzato: Ecoinvent 3.8, SimaPro 9.3.0.3.

*In accordo con la **PCR di riferimento**, il ciclo di vita del prodotto è del tipo "From cradle to grave" ed è stato suddiviso in tre parti:*

- **Upstream processes** (dalla culla al cancello)
- **Core processes** (da cancello a cancello)
- **Downstream processes** (dal cancello alla tomba)

Vengono esclusi dallo studio la fase di installazione (A5) perché non è gestita da CBI Europe e la fase d'uso (B1, B2, B3, B4, B5, B6, B7) perché non è prevista per i controsoffitti.

Cut-off: at least 95% of the energy and materials used by module has been introduced, as well as 99% of the total use of energy and materials

Cut-off: sono stati considerati almeno il 95% dei flussi di energia e dei materiali utilizzati per il processo produttivo, nonché il 99% del consumo totale di energia e materiali.

UPSTREAM			CORE			DOWNSTREAM											Recupero risorse
Fase di produzione materia prima e del prodotto			Fase di costruzione del prodotto			Fase di utilizzo Controsoffitto						Fase di fine vita Controsoffitto					
Raw Material Supply	Trasport	Manufacturing	Trasport	Construction Installation	Use	Maintenance	Repair	Replacement	Refurbishment	Operational Energy Use	Operational Water Use	Deconstruction, demolition	Transport	Waste Processing	Disposal	Future reuse, recycling or energy recovery	
Materie prime	Trasporti	Produzione	Trasporti	Installazione	Utilizzo	Manutenzioni	Riparazioni	Sostituzioni	Ristrutturazioni	Operazioni di utilizzo di energia	Operazioni di utilizzo di acqua	Demolizione / Rimozione	Trasporto	Trattamento dei rifiuti	Discarica	Riutilizzo - Recupero - Riciclo Potenziale	
A1	A2	A3	A4	A5	B1	B2	B3	B4	B5	B6	B7	C1	C2	C3	C4	D	
X	X	X	X	FND	FND	FND	FND	FND	FND	FND	FND	X	X	X	X	X	
				MND	MND	MND	MND	MND	MND	MND	MND						

Caption: X = Included in LCA; FND: Form Not Declared - Didascalia: X = Incluso in LCA; MND: Modulo Non Dichiarato

The following image shows the system boundaries graphically.

Nell'immagine che segue vengono riportati graficamente i confini del sistema.

A- PRODUCT STAGE
A - PRODOTTO E FASE DI COSTRUZIONE

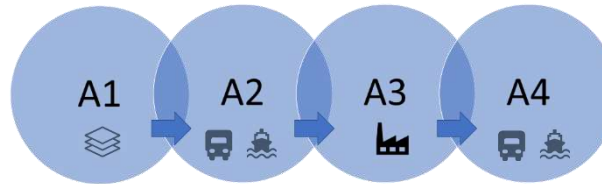

C- END OF LIFE STAGE
C - FASE DI FINE VITA

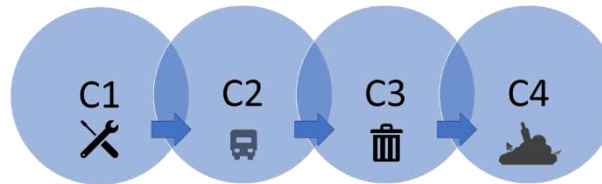

D – RESOURCE RECOVERY

D – RECUPERO RISORSE

3. Description of phases, allocations and hypotheses adopted in the study

3. Descrizione fasi, allocazioni e ipotesi adottate nello studio

PHASE FASE	DESCRIPTION OF PHASES, ALLOCATIONS AND HYPOTHESES ADOPTED IN THE STUDY	DESCRIZIONE FASI, ALLOCAZIONI E IPOTESI ADOTTATE NELLO STUDIO
	<u>Raw materials</u>	<u>Materia Prima</u>
	<i>Key raw materials used for CBI Europe products considered in LCA study are the following:</i>	<i>Le materie prime chiave utilizzate nei prodotti CBI Europe considerati nello studio LCA sono le seguenti:</i>
A1	<ul style="list-style-type: none">• <i>Panels Sherwood and Soundwood: fire resistant MDF with a natural wood finish or with a melamine finish.</i>• <i>Panels Acoustik Plus: plaster fireboard</i>• <i>Lamella Sherwood and Soundwood: fire resistant MDF with a natural wood finish or with a melamine finish.</i>• <i>Solid wood Lamelle: legno massello di abete</i>• <i>Structures: galvanised steel, pre-painted steel.</i>	<ul style="list-style-type: none">• <i>Panelli Sherwood e Soundwood: MDF ignifugo con finitura in legno naturale o con finitura melaminico</i>• <i>Pannelli Acoustic plus: gesso e fibra di legno</i>• <i>Lamelle: Sherwood e Sounwood: MDF ignifugo con finitura in legno naturale o con finitura melaminico</i>• <i>Solid wood Lamelle: legno massello di abete</i>• <i>Strutture: acciaio zincato, acciaio pre-verniciato</i>
	<u>Transport to factory</u>	<u>Trasporto allo stabilimento</u>
A2	<i>For all materials the transport to the production plant was estimated based on the position of the suppliers of CBI Europe.</i>	<i>Per tutti i materiali il trasporto allo stabilimento produttivo è stato stimato a partire dalla localizzazione geografica dei fornitori di CBI Europe.</i>
	<u>Production</u>	<u>Produzione</u>
A3		

PHASE FASE	DESCRIPTION OF PHASES, ALLOCATIONS AND HYPOTHESES ADOPTED IN THE STUDY	DESCRIZIONE FASI, ALLOCAZIONI E IPOTESI ADOTTATE NELLO STUDIO
	<p>All CBI Europe products are manufactured in its headquarter located in Osimo (AN).</p>	<p><i>Tutti i prodotti CBI Europe sono realizzati nella sede centrale localizzata ad Osimo AN.</i></p>
	<p>CBI Europe buys MDF panels in sheets with dimensions 2070x3760. The panels are cut according to the specific requests of the customer and milled in the edges according to the type of system chosen to house the structure. In the case of perforated panels, CBI Europe proceeds with the perforation and the application of the thermo-adhesive fabric through a special heating machine. In the case of Acoustik Plus panels, the gypsum/wood panel is coupled with wood essences purchased to measure in the specific format requested by the customer.</p>	<p><i>CBI Europe acquista i pannelli in MDF in fogli di dimensioni 2070x3760. I pannelli vengono sezionati in base alle specifiche richieste del cliente e fresati nei bordi a seconda del tipo di sistema scelto per alloggiare la struttura. Nel caso di pannelli forati CBI Europe procede alla foratura ad applicazione del tessuto termo-autoadesivo tramite apposito macchinario riscaldante. Nel caso di pannelli del tipo Acoustik Plus il pannello in gesso/legno viene accoppiato con le essenze di legno acquistate su misura del formato specifico richiesto dal cliente.</i></p>
	<p>For the realization of the structures CBI Europe buys the steel in coils of width 1300-1500 mm. The coils are cut internally into subcoils, adapting the width to the type of ceiling to be produced. The subcoils are then processed in profiling, bending and pressing machines. After passing through the machinery, the finished product is available for sale.</p>	<p><i>Per la realizzazione delle strutture CBI Europe acquista l'acciaio in coils di larghezza da 1300-1500 mm. I coils vengono tagliati internamente in sottocoils poi processati in macchine profilatrici, piegatrici e pressatrici. Dopo il passaggio nei macchinari il prodotto finito è disponibile per essere venduto.</i></p>
	<p>The criteria of mass has been used to properly allocate the flow of the plant to the product considered in LCA. Electricity consumption and waste were allocated in relation to the mass of products under study.</p>	<p><i>Per ripartire tutti i flussi aziendali è stato applicato un criterio di massa. I consumi di energia elettrica e i rifiuti sono stati allocati in relazione alla massa dei prodotti oggetto di studio.</i></p>
	<p>Regarding electricity, the LCA study considered renewable sources only for business consumption for the production of ceiling and cladding structures; while for all other processes the national energy mix was considered, suitably modified according to the "residual mix" method; while the national energetic mix, properly modified according to the "residual mix" method has been considered for all other processes.</p>	<p><i>Per quanto riguarda l'energia elettrica, lo studio LCA ha considerato le fonti rinnovabili solo per il consumo aziendale per la produzione delle strutture di controsoffitti e rivestimenti; mentre per tutti gli altri processi è stato considerato il mix energetico nazionale, opportunamente modificato secondo il metodo del "mix residuo".</i></p>

PHASE FASE	DESCRIPTION OF PHASES, ALLOCATIONS AND HYPOTHESES ADOPTED IN THE STUDY	DESCRIZIONE FASI, ALLOCAZIONI E IPOTESI ADOTTATE NELLO STUDIO
A4	<p><u>Transport from the company gate to the site</u></p> <p>Products are loaded directly onto the truck in the factory. Delivery is made using the customer's carriers.</p>	<p><u>Trasporto dallo stabilimento al sito</u></p> <p><i>I prodotti vengono caricati direttamente sui mezzi di trasporto in stabilimento. La consegna viene effettuata utilizzando i vettori del cliente.</i></p>
C1	<p><u>De – construction/demolition</u></p> <p>The de-contruction/demolition activites are generally carried out handly without using energy-intensive machinery.</p>	<p><u>Demolizione / Rimozione</u></p> <p><i>Le attività di rimozione dei controsoffitti e rivestimenti in legno vengono svolte manualmente senza l'utilizzo di macchinari energivori.</i></p>
C2	<p><u>Transport to recycling sites for final disposal</u></p> <p><i>The distance between the installation site and the recycling and final disposal centers is assumed to be 150 km, by truck, EURO 4.</i></p>	<p><u>Trasporto ai siti di riciclo e smaltimento finale</u></p> <p><i>La distanza tra il sito di installazione e i centri di riciclo e smaltimento finale dei rifiuti viene ipotizzata pari a 150 Km, via camion, EURO 4.</i></p>
C3	<p><u>Waste processing</u></p> <p>The energy contained in MDF panels and steel structures cannot be recovered during waste treatment. So, this stage is considered to be 0. For wood panels, it has been assumed that these are destined for recycling and to a small extent for landfill disposal and incineration without energy recovery.</p>	<p><u>Trattamento dei rifiuti</u></p> <p><i>L'energia contenuta nei pannelli in MDF e in acciaio non può essere recuperata durante il trattamento dei rifiuti. Per questo motivo questa fase è considerata pari a 0. Per i pannelli in legno è stato ipotizzato che questi siano destinati al riciclo e in minima parte allo smaltimento in discarica e all'incenerimento senza recupero energetico.</i></p>
C4	<p><u>Waste disposal</u></p>	<p><u>Discarica</u></p>

PHASE	DESCRIPTION OF PHASES, ALLOCATIONS AND HYPOTHESES ADOPTED IN THE STUDY	DESCRIZIONE FASI, ALLOCAZIONI E IPOTESI ADOTTATE NELLO STUDIO
FASE		
	<p>According to the "Rapporto rifiuti urbani ISPRA, Edizione 2021", the percentage of wood waste sent for recycling is 62%. The remaining 35% is sent to landfills and 2% is destined for incineration / energy recovery.</p>	<p><i>Secondo il "Rapporto rifiuti urbani ISPRA, Edizione 2021" la percentuale di rifiuti di legno inviati a riciclo è pari al 62%. Il restante 35% viene smaltito in discarica e il 2% viene destinato ad incenerimento/recupero energetico.</i></p>
	<p>According to the World Steel Association, the percentage of steel waste sent for recycling is 85%. The remaining 15% is sent to landfills and 0% is destined for incineration / energy recovery.</p>	<p><i>Secondo la World Steel Association, la percentuale di rifiuti di acciaio inviati a riciclo è pari all'85%. Il restante 15% viene inviato in discarica e lo 0% viene destinato ad incenerimento/recupero energetico.</i></p>
	<p><u>Reuse- Recovery- Recycling potential</u></p>	<p><u>Riutilizzo – Recupero – Riciclo potenziale</u></p>
D	<p>According to the "Rapporto rifiuti urbani ISPRA, Edizione 2021" the wood waste sent to recovery is equal to 62%.</p>	<p><i>Secondo il "Rapporto rifiuti urbani ISPRA, Edizione 2021" i rifiuti di legno destinati al recupero sono pari al 62%.</i></p>
	<p>According to the World Steel Association the steel waste sent to recovery is equal to 85%.</p>	<p><i>Secondo la World Steel Association i rifiuti di acciaio destinati al recupero sono pari all'85%.</i></p>

Environmental performance of Sherwood and Soundwood Panels, thickness 14 mm - Impact *Performance ambientali dei pannelli Sherwood and Soundwood, spessore 14 mm - Impatti*

Class legend – Material and weight class (kg)

Legenda Classi – Materiale e Classe di peso (Kg)

A:	<i>Sherwood and Soundwood panels, fire resistant MDF</i>	<i>5,34<p<5,88</i>
B:	<i>Sherwood and Soundwood panels, fire resistant MDF</i>	<i>5,88<p<6,47</i>
C:	<i>Sherwood and Soundwood panels, fire resistant MDF</i>	<i>6,47<p<7,11</i>
D:	<i>Sherwood and Soundwood panels, fire resistant MDF</i>	<i>7,11<p<7,83</i>
E:	<i>Sherwood and Soundwood panels, fire resistant MDF</i>	<i>7,83<p<8,61</i>
F:	<i>Sherwood and Soundwood panels, fire resistant MDF</i>	<i>8,61<p<9,47</i>
G:	<i>Sherwood and Soundwood panels, fire resistant MDF</i>	<i>9,47<p<10,42</i>
H:	<i>Sherwood and Soundwood panels, fire resistant MDF</i>	<i>10,42 <p<11,47</i>

Legend – Potential environmental impact:

Legenda impatti:

PEI Potential environment impact

UM Unit of measure

GWP	Global warming potential, total
GWPf	Global warming potential, fossil
GWPb	Global warming potential, biogenic
GWPI	Global warming potential, land use
ODP	Ozone depletion potential
AP	Acidification potential of land and water
EPf	Eutrophication aquatic, freshwater
EPm	Eutrophication aquatic, marine
EPT	Eutrophication aquatic, terrestrial
POCP	Photochemical ozone creation potential
ADPe	Abiotic depletion potential, elements
ADPf	Abiotic depletion potential, fossil
WDP	Water depletion potential

Functional Unit: 1 m² of ceiling/wall covering

Unità funzionale: 1 m² di

controsoffitto/rivestimento

PHASES FASI	PEI	UM	A	B	C	D	E	F	G	H
A1	<i>GWPF</i>	<i>kg CO2 eq</i>	2,06E-01	2,27E-01	2,49E-01	2,74E-01	3,02E-01	3,32E-01	3,65E-01	4,02E-01
	<i>GWPB</i>	<i>kg CO2 eq</i>	4,08E-04	4,49E-04	4,94E-04	5,44E-04	5,98E-04	6,58E-04	7,23E-04	7,96E-04
	<i>GWPI</i>	<i>kg CO2 eq</i>	2,56E-04	2,82E-04	3,10E-04	3,41E-04	3,75E-04	4,12E-04	4,53E-04	4,99E-04
	GWP	kg CO2 eq	2,07E-01	2,27E-01	2,50E-01	2,75E-01	3,03E-01	3,33E-01	3,66E-01	4,03E-01
	<i>AP</i>	<i>mol H+ eq</i>	1,44E-03	1,58E-03	1,74E-03	1,91E-03	2,10E-03	2,31E-03	2,54E-03	2,80E-03
	<i>EPf</i>	<i>kg P eq</i>	8,04E-05	8,84E-05	9,73E-05	1,07E-04	1,18E-04	1,29E-04	1,42E-04	1,57E-04
	<i>EPm</i>	<i>kg N eq</i>	3,55E-04	3,91E-04	4,30E-04	4,73E-04	5,20E-04	5,72E-04	6,29E-04	6,92E-04
	<i>EPT</i>	<i>mol N eq</i>	4,31E-03	4,74E-03	5,21E-03	5,73E-03	6,31E-03	6,94E-03	7,63E-03	8,40E-03
	<i>POCP</i>	<i>kg NMVOC</i>	1,27E-03	1,40E-03	1,54E-03	1,69E-03	1,86E-03	2,05E-03	2,25E-03	2,48E-03
	<i>ADPe</i>	<i>kg Sb eq</i>	2,12E-06	2,34E-06	2,57E-06	2,83E-06	3,11E-06	3,42E-06	3,76E-06	4,14E-06
	<i>ADPf</i>	<i>MJ</i>	3,47E+00	3,81E+00	4,19E+00	4,61E+00	5,07E+00	5,58E+00	6,14E+00	6,75E+00
	<i>WDP</i>	<i>m3 eq</i>	2,06E-01	2,27E-01	2,50E-01	2,75E-01	3,02E-01	3,33E-01	3,66E-01	4,02E-01
	<i>ODP</i>	<i>kg CFC-11 eq</i>	1,99E-08	2,19E-08	2,40E-08	2,65E-08	2,91E-08	3,20E-08	3,52E-08	3,87E-08
A2	<i>GWPF</i>	<i>kg CO2 eq</i>	1,13E-02	1,25E-02	1,37E-02	1,51E-02	1,66E-02	1,82E-02	2,01E-02	2,21E-02
	<i>GWPB</i>	<i>kg CO2 eq</i>	3,34E-06	3,67E-06	4,04E-06	4,44E-06	4,89E-06	5,38E-06	5,92E-06	6,51E-06
	<i>GWPI</i>	<i>kg CO2 eq</i>	4,23E-06	4,65E-06	5,12E-06	5,63E-06	6,19E-06	6,81E-06	7,49E-06	8,24E-06
	GWP	kg CO2 eq	1,13E-02	1,25E-02	1,37E-02	1,51E-02	1,66E-02	1,82E-02	2,01E-02	2,21E-02
	<i>AP</i>	<i>mol H+ eq</i>	5,81E-05	6,39E-05	7,03E-05	7,73E-05	8,51E-05	9,36E-05	1,03E-04	1,13E-04
	<i>EPf</i>	<i>kg P eq</i>	7,18E-07	7,89E-07	8,68E-07	9,55E-07	1,05E-06	1,16E-06	1,27E-06	1,40E-06
	<i>EPm</i>	<i>kg N eq</i>	1,99E-05	2,19E-05	2,41E-05	2,65E-05	2,92E-05	3,21E-05	3,53E-05	3,88E-05
	<i>EPT</i>	<i>mol N eq</i>	2,18E-04	2,40E-04	2,64E-04	2,90E-04	3,19E-04	3,51E-04	3,86E-04	4,25E-04
	<i>POCP</i>	<i>kg NMVOC</i>	6,52E-05	7,17E-05	7,88E-05	8,67E-05	9,54E-05	1,05E-04	1,15E-04	1,27E-04
	<i>ADPe</i>	<i>kg Sb eq</i>	2,64E-08	2,91E-08	3,20E-08	3,52E-08	3,87E-08	4,26E-08	4,68E-08	5,15E-08
	<i>ADPf</i>	<i>MJ</i>	1,76E-01	1,94E-01	2,13E-01	2,34E-01	2,58E-01	2,84E-01	3,12E-01	3,43E-01
	<i>WDP</i>	<i>m3 depriv.</i>	6,22E-04	6,84E-04	7,52E-04	8,27E-04	9,10E-04	1,00E-03	1,10E-03	1,21E-03
	<i>ODP</i>	<i>kg CFC-11 eq</i>	2,18E-09	2,40E-09	2,64E-09	2,90E-09	3,19E-09	3,51E-09	3,86E-09	4,24E-09
A3	<i>GWPF</i>	<i>kg CO2 eq</i>	1,16E-01	1,27E-01	1,40E-01	1,54E-01	1,70E-01	1,87E-01	2,05E-01	2,26E-01
	<i>GWPB</i>	<i>kg CO2 eq</i>	3,37E-04	3,71E-04	4,08E-04	4,49E-04	4,94E-04	5,43E-04	5,97E-04	6,57E-04
	<i>GWPI</i>	<i>kg CO2 eq</i>	2,93E-05	3,22E-05	3,54E-05	3,90E-05	4,29E-05	4,71E-05	5,19E-05	5,70E-05
	GWP	kg CO2 eq	1,16E-01	1,28E-01	1,41E-01	1,55E-01	1,70E-01	1,87E-01	2,06E-01	2,27E-01
	<i>AP</i>	<i>mol H+ eq</i>	5,13E-04	5,64E-04	6,20E-04	6,82E-04	7,51E-04	8,26E-04	9,08E-04	9,99E-04
	<i>EPf</i>	<i>kg P eq</i>	2,62E-05	2,88E-05	3,16E-05	3,48E-05	3,83E-05	4,21E-05	4,63E-05	5,10E-05
	<i>EPm</i>	<i>kg N eq</i>	9,04E-05	9,95E-05	1,09E-04	1,20E-04	1,32E-04	1,46E-04	1,60E-04	1,76E-04
	<i>EPT</i>	<i>mol N eq</i>	9,55E-04	1,05E-03	1,16E-03	1,27E-03	1,40E-03	1,54E-03	1,69E-03	1,86E-03
	<i>POCP</i>	<i>kg NMVOC</i>	2,73E-04	3,01E-04	3,31E-04	3,64E-04	4,00E-04	4,40E-04	4,84E-04	5,33E-04
	<i>ADPe</i>	<i>kg Sb eq</i>	1,50E-07	1,65E-07	1,82E-07	2,00E-07	2,20E-07	2,42E-07	2,66E-07	2,93E-07
<i>ADPf</i>	<i>MJ</i>	1,55E+00	1,71E+00	1,88E+00	2,06E+00	2,27E+00	2,50E+00	2,75E+00	3,02E+00	

PHASES FASI	PEI	UM	A	B	C	D	E	F	G	H
	WDP	m3 depriv.	3,21E-02	3,54E-02	3,89E-02	4,28E-02	4,71E-02	5,18E-02	5,69E-02	6,26E-02
	ODP	kg CFC-11 eq	1,36E-08	1,49E-08	1,64E-08	1,81E-08	1,99E-08	2,19E-08	2,41E-08	2,65E-08
A4	GWPf	kg CO2 eq	3,73E-02	4,11E-02	4,52E-02	4,97E-02	5,47E-02	6,01E-02	6,62E-02	7,28E-02
	GWPb	kg CO2 eq	9,43E-06	1,04E-05	1,14E-05	1,25E-05	1,38E-05	1,52E-05	1,67E-05	1,84E-05
	GWPI	kg CO2 eq	1,99E-05	2,19E-05	2,41E-05	2,65E-05	2,92E-05	3,21E-05	3,53E-05	3,89E-05
	GWP	kg CO2 eq	3,74E-02	4,11E-02	4,52E-02	4,98E-02	5,47E-02	6,02E-02	6,62E-02	7,28E-02
	AP	mol H+ eq	5,82E-04	6,40E-04	7,04E-04	7,75E-04	8,52E-04	9,37E-04	1,03E-03	1,13E-03
	EPf	kg P eq	2,05E-06	2,26E-06	2,49E-06	2,74E-06	3,01E-06	3,31E-06	3,64E-06	4,00E-06
	EPm	kg N eq	1,55E-04	1,70E-04	1,87E-04	2,06E-04	2,26E-04	2,49E-04	2,74E-04	3,01E-04
	EPT	mol N eq	1,71E-03	1,88E-03	2,07E-03	2,28E-03	2,51E-03	2,76E-03	3,03E-03	3,33E-03
	POCP	kg NMVOC	4,55E-04	5,00E-04	5,50E-04	6,05E-04	6,66E-04	7,32E-04	8,06E-04	8,86E-04
	ADPe	kg Sb eq	1,01E-07	1,11E-07	1,23E-07	1,35E-07	1,48E-07	1,63E-07	1,79E-07	1,97E-07
	ADPf	MJ	5,29E-01	5,82E-01	6,41E-01	7,05E-01	7,75E-01	8,53E-01	9,38E-01	1,03E+00
	WDP	m3 depriv.	1,44E-03	1,58E-03	1,74E-03	1,91E-03	2,10E-03	2,31E-03	2,55E-03	2,80E-03
	ODP	kg CFC-11 eq	6,49E-09	7,14E-09	7,85E-09	8,64E-09	9,50E-09	1,05E-08	1,15E-08	1,26E-08
	C1	GWPf	kg CO2 eq	0,00E+00	0,00E+00	0,00E+00	0,00E+00	0,00E+00	0,00E+00	0,00E+00
GWPb		kg CO2 eq	0,00E+00	0,00E+00	0,00E+00	0,00E+00	0,00E+00	0,00E+00	0,00E+00	0,00E+00
GWPI		kg CO2 eq	0,00E+00	0,00E+00	0,00E+00	0,00E+00	0,00E+00	0,00E+00	0,00E+00	0,00E+00
GWP		kg CO2 eq	0,00E+00	0,00E+00	0,00E+00	0,00E+00	0,00E+00	0,00E+00	0,00E+00	0,00E+00
AP		mol H+ eq	0,00E+00	0,00E+00	0,00E+00	0,00E+00	0,00E+00	0,00E+00	0,00E+00	0,00E+00
EPf		kg P eq	0,00E+00	0,00E+00	0,00E+00	0,00E+00	0,00E+00	0,00E+00	0,00E+00	0,00E+00
EPm		kg N eq	0,00E+00	0,00E+00	0,00E+00	0,00E+00	0,00E+00	0,00E+00	0,00E+00	0,00E+00
EPT		mol N eq	0,00E+00	0,00E+00	0,00E+00	0,00E+00	0,00E+00	0,00E+00	0,00E+00	0,00E+00
POCP		kg NMVOC	0,00E+00	0,00E+00	0,00E+00	0,00E+00	0,00E+00	0,00E+00	0,00E+00	0,00E+00
ADPe		kg Sb eq	0,00E+00	0,00E+00	0,00E+00	0,00E+00	0,00E+00	0,00E+00	0,00E+00	0,00E+00
ADPf		MJ	0,00E+00	0,00E+00	0,00E+00	0,00E+00	0,00E+00	0,00E+00	0,00E+00	0,00E+00
WDP		m3 depriv.	0,00E+00	0,00E+00	0,00E+00	0,00E+00	0,00E+00	0,00E+00	0,00E+00	0,00E+00
ODP		kg CFC-11 eq	0,00E+00	0,00E+00	0,00E+00	0,00E+00	0,00E+00	0,00E+00	0,00E+00	0,00E+00
C2		GWPf	kg CO2 eq	7,16E-03	7,88E-03	8,67E-03	9,54E-03	1,05E-02	1,15E-02	1,27E-02
	GWPb	kg CO2 eq	1,98E-06	2,18E-06	2,40E-06	2,64E-06	2,91E-06	3,20E-06	3,52E-06	3,87E-06
	GWPI	kg CO2 eq	3,10E-06	3,41E-06	3,75E-06	4,12E-06	4,53E-06	4,99E-06	5,49E-06	6,04E-06
	GWP	kg CO2 eq	7,17E-03	7,89E-03	8,68E-03	9,54E-03	1,05E-02	1,15E-02	1,27E-02	1,40E-02
	AP	mol H+ eq	3,68E-05	4,04E-05	4,45E-05	4,89E-05	5,38E-05	5,92E-05	6,51E-05	7,16E-05
	EPf	kg P eq	5,45E-07	5,99E-07	6,59E-07	7,25E-07	7,98E-07	8,77E-07	9,65E-07	1,06E-06
	EPm	kg N eq	1,24E-05	1,37E-05	1,51E-05	1,66E-05	1,82E-05	2,00E-05	2,20E-05	2,42E-05
	EPT	mol N eq	1,36E-04	1,50E-04	1,65E-04	1,81E-04	1,99E-04	2,19E-04	2,41E-04	2,65E-04
POCP	kg NMVOC	3,87E-05	4,26E-05	4,68E-05	5,15E-05	5,67E-05	6,23E-05	6,86E-05	7,54E-05	

Environmental performance of Sherwood and Soundwood Panels, thickness 14 mm – Use of resources

Performance ambientali dei pannelli Sherwood and Soundwood, spessore 14 mm – Consumo di risorse

Class legend – Material and weight class (kg)

Legenda Classi – Materiale e Classe di peso (Kg)

A:	<i>Sherwood and Soundwood panels, fire resistant MDF</i>	<i>5,34<p<5,88</i>
B:	<i>Sherwood and Soundwood panels, fire resistant MDF</i>	<i>5,88<p<6,47</i>
C:	<i>Sherwood and Soundwood panels, fire resistant MDF</i>	<i>6,47<p<7,11</i>
D:	<i>Sherwood and Soundwood panels, fire resistant MDF</i>	<i>7,11<p<7,83</i>
E:	<i>Sherwood and Soundwood panels, fire resistant MDF</i>	<i>7,83<p<8,61</i>
F:	<i>Sherwood and Soundwood panels, fire resistant MDF</i>	<i>8,61<p<9,47</i>
G:	<i>Sherwood and Soundwood panels, fire resistant MDF</i>	<i>9,47<p<10,42</i>
H:	<i>Sherwood and Soundwood panels, fire resistant MDF</i>	<i>10,42 <p<11,47</i>

Legend – Potential environmental impact:

Legenda impatti:

PEI Potential environment impact

UM Unit of measure

GWP	Global warming potential, total
GWPf	Global warming potential, fossil
GWPb	Global warming potential, biogenic
GWPI	Global warming potential, land use
ODP	Ozone depletion potential
AP	Acidification potential of land and water
EPf	Eutrophication aquatic, freshwater
EPm	Eutrophication aquatic, marine
EPT	Eutrophication aquatic, terrestrial
POCP	Photochemical ozone creation potential
ADPe	Abiotic depletion potential, elements
ADPf	Abiotic depletion potential, fossil
WDP	Water depletion potential

Functional Unit: 1 m² of ceiling/wall covering

Unità funzionale: 1 m² di controsoffitto/rivestimento

PHASES FASI	PEI	UM	A	B	C	D	E	F	G	H
	<i>RSF</i>	<i>MJ</i>	0,00E+00	0,00E+00	0,00E+00	0,00E+00	0,00E+00	0,00E+00	0,00E+00	0,00E+00
	<i>NRSF</i>	<i>MJ</i>	0,00E+00	0,00E+00	0,00E+00	0,00E+00	0,00E+00	0,00E+00	0,00E+00	0,00E+00
	<i>FW</i>	<i>m3</i>	3,84E-04	4,22E-04	4,64E-04	5,11E-04	5,62E-04	6,18E-04	6,80E-04	7,48E-04
C1	<i>PERE</i>	<i>MJ</i>	0,00E+00	0,00E+00	0,00E+00	0,00E+00	0,00E+00	0,00E+00	0,00E+00	0,00E+00
	<i>PERM</i>	<i>MJ</i>	0,00E+00	0,00E+00	0,00E+00	0,00E+00	0,00E+00	0,00E+00	0,00E+00	0,00E+00
	<i>PERT</i>	<i>MJ</i>	0,00E+00	0,00E+00	0,00E+00	0,00E+00	0,00E+00	0,00E+00	0,00E+00	0,00E+00
	<i>PENRE</i>	<i>MJ</i>	0,00E+00	0,00E+00	0,00E+00	0,00E+00	0,00E+00	0,00E+00	0,00E+00	0,00E+00
	<i>PENRM</i>	<i>MJ</i>	0,00E+00	0,00E+00	0,00E+00	0,00E+00	0,00E+00	0,00E+00	0,00E+00	0,00E+00
	<i>PENRT</i>	<i>MJ</i>	0,00E+00	0,00E+00	0,00E+00	0,00E+00	0,00E+00	0,00E+00	0,00E+00	0,00E+00
	<i>SM</i>	<i>kg</i>	0,00E+00	0,00E+00	0,00E+00	0,00E+00	0,00E+00	0,00E+00	0,00E+00	0,00E+00
	<i>RSF</i>	<i>MJ</i>	0,00E+00	0,00E+00	0,00E+00	0,00E+00	0,00E+00	0,00E+00	0,00E+00	0,00E+00
	<i>NRSF</i>	<i>MJ</i>	0,00E+00	0,00E+00	0,00E+00	0,00E+00	0,00E+00	0,00E+00	0,00E+00	0,00E+00
	<i>FW</i>	<i>m3</i>	0,00E+00	0,00E+00	0,00E+00	0,00E+00	0,00E+00	0,00E+00	0,00E+00	0,00E+00
C2	<i>PERE</i>	<i>MJ</i>	8,77E-04	9,65E-04	1,06E-03	1,17E-03	1,28E-03	1,41E-03	1,55E-03	1,71E-03
	<i>PERM</i>	<i>MJ</i>	3,66E-04	4,03E-04	4,43E-04	4,87E-04	5,36E-04	5,90E-04	6,49E-04	7,14E-04
	<i>PERT</i>	<i>MJ</i>	1,24E-03	1,37E-03	1,50E-03	1,66E-03	1,82E-03	2,00E-03	2,20E-03	2,42E-03
	<i>PENRE</i>	<i>MJ</i>	1,06E-01	1,17E-01	1,29E-01	1,41E-01	1,56E-01	1,71E-01	1,88E-01	2,07E-01
	<i>PENRM</i>	<i>MJ</i>	0,00E+00	0,00E+00	0,00E+00	0,00E+00	0,00E+00	0,00E+00	0,00E+00	0,00E+00
	<i>PENRT</i>	<i>MJ</i>	1,06E-01	1,17E-01	1,29E-01	1,41E-01	1,56E-01	1,71E-01	1,88E-01	2,07E-01
	<i>SM</i>	<i>kg</i>	0,00E+00	0,00E+00	0,00E+00	0,00E+00	0,00E+00	0,00E+00	0,00E+00	0,00E+00
	<i>RSF</i>	<i>MJ</i>	0,00E+00	0,00E+00	0,00E+00	0,00E+00	0,00E+00	0,00E+00	0,00E+00	0,00E+00
	<i>NRSF</i>	<i>MJ</i>	0,00E+00	0,00E+00	0,00E+00	0,00E+00	0,00E+00	0,00E+00	0,00E+00	0,00E+00
	<i>FW</i>	<i>m3</i>	8,68E-05	9,54E-05	1,05E-04	1,15E-04	1,27E-04	1,40E-04	1,54E-04	1,69E-04
C3	<i>PERE</i>	<i>MJ</i>	0,00E+00	0,00E+00	0,00E+00	0,00E+00	0,00E+00	0,00E+00	0,00E+00	0,00E+00
	<i>PERM</i>	<i>MJ</i>	0,00E+00	0,00E+00	0,00E+00	0,00E+00	0,00E+00	0,00E+00	0,00E+00	0,00E+00
	<i>PERT</i>	<i>MJ</i>	0,00E+00	0,00E+00	0,00E+00	0,00E+00	0,00E+00	0,00E+00	0,00E+00	0,00E+00
	<i>PENRE</i>	<i>MJ</i>	0,00E+00	0,00E+00	0,00E+00	0,00E+00	0,00E+00	0,00E+00	0,00E+00	0,00E+00
	<i>PENRM</i>	<i>MJ</i>	0,00E+00	0,00E+00	0,00E+00	0,00E+00	0,00E+00	0,00E+00	0,00E+00	0,00E+00
	<i>PENRT</i>	<i>MJ</i>	0,00E+00	0,00E+00	0,00E+00	0,00E+00	0,00E+00	0,00E+00	0,00E+00	0,00E+00
	<i>SM</i>	<i>kg</i>	0,00E+00	0,00E+00	0,00E+00	0,00E+00	0,00E+00	0,00E+00	0,00E+00	0,00E+00
	<i>RSF</i>	<i>MJ</i>	0,00E+00	0,00E+00	0,00E+00	0,00E+00	0,00E+00	0,00E+00	0,00E+00	0,00E+00
	<i>NRSF</i>	<i>MJ</i>	0,00E+00	0,00E+00	0,00E+00	0,00E+00	0,00E+00	0,00E+00	0,00E+00	0,00E+00
	<i>FW</i>	<i>m3</i>	0,00E+00	0,00E+00	0,00E+00	0,00E+00	0,00E+00	0,00E+00	0,00E+00	0,00E+00
C4	<i>PERE</i>	<i>MJ</i>	7,95E-04	8,74E-04	9,62E-04	1,06E-03	1,16E-03	1,28E-03	1,41E-03	1,55E-03
	<i>PERM</i>	<i>MJ</i>	3,05E-04	3,35E-04	3,69E-04	4,06E-04	4,46E-04	4,91E-04	5,40E-04	5,94E-04
	<i>PERT</i>	<i>MJ</i>	1,10E-03	1,21E-03	1,33E-03	1,46E-03	1,61E-03	1,77E-03	1,95E-03	2,14E-03
	<i>PENRE</i>	<i>MJ</i>	5,24E-02	5,77E-02	6,34E-02	6,98E-02	7,67E-02	8,44E-02	9,29E-02	1,02E-01

Environmental performance of Sherwood and Soundwood Panels, thickness 14 mm – Waste production and output flows

Performance ambientali dei pannelli Sherwood and Soundwood, spessore 14 mm – Produzione di rifiuti e flussi in output

Class legend – Material and weight class (kg)

Legenda Classi – Materiale e Classe di peso (Kg)

A:	<i>Sherwood and Soundwood panels, fire resistant MDF</i>	<i>5,34<p<5,88</i>
B:	<i>Sherwood and Soundwood panels, fire resistant MDF</i>	<i>5,88<p<6,47</i>
C:	<i>Sherwood and Soundwood panels, fire resistant MDF</i>	<i>6,47<p<7,11</i>
D:	<i>Sherwood and Soundwood panels, fire resistant MDF</i>	<i>7,11<p<7,83</i>
E:	<i>Sherwood and Soundwood panels, fire resistant MDF</i>	<i>7,83<p<8,61</i>
F:	<i>Sherwood and Soundwood panels, fire resistant MDF</i>	<i>8,61<p<9,47</i>
G:	<i>Sherwood and Soundwood panels, fire resistant MDF</i>	<i>9,47<p<10,42</i>
H:	<i>Sherwood and Soundwood panels, fire resistant MDF</i>	<i>10,42 <p<11,47</i>

Legend – Potential environmental impact:

Legenda impatti:

PEI Potential environment impact

UM Unit of measure

GWP	Global warming potential, total
GWPf	Global warming potential, fossil
GWPb	Global warming potential, biogenic
GWPI	Global warming potential, land use
ODP	Ozone depletion potential
AP	Acidification potential of land and water
EPf	Eutrophication aquatic, freshwater
EPm	Eutrophication aquatic, marine
EPt	Eutrophication aquatic, terrestrial
POCP	Photochemical ozone creation potential
ADPe	Abiotic depletion potential, elements
ADPf	Abiotic depletion potential, fossil
WDP	Water depletion potential

Functional Unit: 1 m² of ceiling/wall covering

Unità funzionale: 1 m² di controsoffitto/rivestimento

PHASES FASI	WASTE RIFIUTI	UM	A	B	C	D	E	F	G	H
A1	HWD	kg	4,62E-06	5,09E-06	5,59E-06	6,15E-06	6,77E-06	7,45E-06	8,19E-06	9,01E-06
	NHWD	kg	3,55E-02	3,90E-02	4,29E-02	4,72E-02	5,19E-02	5,71E-02	6,28E-02	6,91E-02
	RWD	kg	8,60E-06	9,46E-06	1,04E-05	1,15E-05	1,26E-05	1,39E-05	1,52E-05	1,68E-05
A2	HWD	kg	4,34E-07	4,78E-07	5,26E-07	5,78E-07	6,36E-07	7,00E-07	7,70E-07	8,46E-07
	NHWD	kg	1,68E-02	1,85E-02	2,04E-02	2,24E-02	2,46E-02	2,71E-02	2,98E-02	3,28E-02
	RWD	kg	1,22E-06	1,34E-06	1,47E-06	1,62E-06	1,78E-06	1,96E-06	2,15E-06	2,37E-06
A3	HWD	kg	2,26E-06	2,48E-06	2,73E-06	3,01E-06	3,31E-06	3,64E-06	4,00E-06	4,40E-06
	NHWD	kg	4,49E-02	4,93E-02	5,43E-02	5,97E-02	6,57E-02	7,22E-02	7,95E-02	8,74E-02
	RWD	kg	1,43E-06	1,58E-06	1,74E-06	1,91E-06	2,10E-06	2,31E-06	2,54E-06	2,80E-06
A4	HWD	kg	1,10E-06	1,21E-06	1,33E-06	1,46E-06	1,61E-06	1,77E-06	1,95E-06	2,14E-06
	NHWD	kg	1,87E-02	2,05E-02	2,26E-02	2,49E-02	2,73E-02	3,01E-02	3,31E-02	3,64E-02
	RWD	kg	3,64E-06	4,01E-06	4,41E-06	4,85E-06	5,34E-06	5,87E-06	6,46E-06	7,10E-06
C1	HWD	kg	0,00E+00	0,00E+00	0,00E+00	0,00E+00	0,00E+00	0,00E+00	0,00E+00	0,00E+00
	NHWD	kg	0,00E+00	0,00E+00	0,00E+00	0,00E+00	0,00E+00	0,00E+00	0,00E+00	0,00E+00
	RWD	kg	0,00E+00	0,00E+00	0,00E+00	0,00E+00	0,00E+00	0,00E+00	0,00E+00	0,00E+00
C2	HWD	kg	2,84E-07	3,13E-07	3,44E-07	3,78E-07	4,16E-07	4,58E-07	5,04E-07	5,54E-07
	NHWD	kg	5,48E-03	6,02E-03	6,63E-03	7,29E-03	8,02E-03	8,82E-03	9,70E-03	1,07E-02
	RWD	kg	7,03E-07	7,73E-07	8,51E-07	9,36E-07	1,03E-06	1,13E-06	1,25E-06	1,37E-06
C3	HWD	kg	0,00E+00	0,00E+00	0,00E+00	0,00E+00	0,00E+00	0,00E+00	0,00E+00	0,00E+00
	NHWD	kg	0,00E+00	0,00E+00	0,00E+00	0,00E+00	0,00E+00	0,00E+00	0,00E+00	0,00E+00
	RWD	kg	0,00E+00	0,00E+00	0,00E+00	0,00E+00	0,00E+00	0,00E+00	0,00E+00	0,00E+00
C4	HWD	kg	9,70E-08	1,07E-07	1,17E-07	1,29E-07	1,42E-07	1,56E-07	1,72E-07	1,89E-07
	NHWD	kg	4,24E-01	4,66E-01	5,13E-01	5,64E-01	6,20E-01	6,82E-01	7,51E-01	8,26E-01
	RWD	kg	2,42E-07	2,66E-07	2,93E-07	3,22E-07	3,55E-07	3,90E-07	4,29E-07	4,72E-07
D	HWD	kg	0,00E+00	0,00E+00	0,00E+00	0,00E+00	0,00E+00	0,00E+00	0,00E+00	0,00E+00
	NHWD	kg	0,00E+00	0,00E+00	0,00E+00	0,00E+00	0,00E+00	0,00E+00	0,00E+00	0,00E+00
	RWD	kg	0,00E+00	0,00E+00	0,00E+00	0,00E+00	0,00E+00	0,00E+00	0,00E+00	0,00E+00
TOTAL TOTALE	HWD	kg	8,80E-06	9,68E-06	1,06E-05	1,17E-05	1,29E-05	1,42E-05	1,56E-05	1,71E-05
	NHWD	kg	5,45E-01	6,00E-01	6,60E-01	7,26E-01	7,98E-01	8,78E-01	9,66E-01	1,06E+00
	RWD	kg	1,58E-05	1,74E-05	1,92E-05	2,11E-05	2,32E-05	2,55E-05	2,81E-05	3,09E-05

Environmental performance of Sherwood and Soundwood Panels, thickness 15 mm - Impact *Performance ambientali dei pannelli Sherwood and Soundwood, spessore 15 mm - Impatti*

Class legend – Material and weight class (kg)

Legenda Classi – Materiale e Classe di peso (Kg)

A:	<i>Sherwood and Soundwood panels, fire resistant MDF</i>	<i>5,15<p<5,66</i>
B:	<i>Sherwood and Soundwood panels, fire resistant MDF</i>	<i>5,66<p<6,23</i>
C:	<i>Sherwood and Soundwood panels, fire resistant MDF</i>	<i>6,23<p<6,85</i>
D:	<i>Sherwood and Soundwood panels, fire resistant MDF</i>	<i>6,85<p<7,53</i>
E:	<i>Sherwood and Soundwood panels, fire resistant MDF</i>	<i>7,53<p<8,29</i>
F:	<i>Sherwood and Soundwood panels, fire resistant MDF</i>	<i>8,29<p<9,11</i>
G:	<i>Sherwood and Soundwood panels, fire resistant MDF</i>	<i>9,11<p<10,03</i>
H:	<i>Sherwood and Soundwood panels, fire resistant MDF</i>	<i>10,03 <p<11,03</i>
I:	<i>Sherwood and Soundwood panels, fire resistant MDF</i>	<i>11,03 <p<12,13</i>

Legend – Potential environmental impact:

Legenda impatti:

PEI Potential environment impact

UM Unit of measure

GWP	Global warming potential, total
GWPf	Global warming potential, fossil
GWPb	Global warming potential, biogenic
GWPI	Global warming potential, land use
ODP	Ozone depletion potential
AP	Acidification potential of land and water
EPf	Eutrophication aquatic, freshwater
EPm	Eutrophication aquatic, marine
EPT	Eutrophication aquatic, terrestrial
POCP	Photochemical ozone creation potential
ADPe	Abiotic depletion potential, elements
ADPf	Abiotic depletion potential, fossil
WDP	Water depletion potential

Functional Unit: 1 m² of ceiling/wall covering

Unità funzionale: 1 m² di controsoffitto/rivestimento

PHASES	PEI	UM	A	B	C	D	E	F	G	H	I
FASI											
A1	GWPf	kg CO2 eq	1,98E-01	2,18E-01	2,40E-01	2,64E-01	2,90E-01	3,19E-01	3,51E-01	3,86E-01	4,25E-01
	GWPb	kg CO2 eq	3,93E-04	4,32E-04	4,76E-04	5,23E-04	5,75E-04	6,33E-04	6,96E-04	7,66E-04	8,42E-04
	GWPI	kg CO2 eq	2,46E-04	2,71E-04	2,98E-04	3,28E-04	3,61E-04	3,97E-04	4,36E-04	4,80E-04	5,28E-04
	GWP	kg CO2 eq	1,99E-01	2,19E-01	2,41E-01	2,65E-01	2,91E-01	3,20E-01	3,52E-01	3,88E-01	4,26E-01
	AP	mol H+ eq	1,38E-03	1,52E-03	1,67E-03	1,84E-03	2,02E-03	2,23E-03	2,45E-03	2,69E-03	2,96E-03
	EPf	kg P eq	7,73E-05	8,51E-05	9,36E-05	1,03E-04	1,13E-04	1,25E-04	1,37E-04	1,51E-04	1,66E-04
	EPm	kg N eq	3,42E-04	3,76E-04	4,14E-04	4,55E-04	5,01E-04	5,51E-04	6,06E-04	6,66E-04	7,33E-04
	EPT	mol N eq	4,15E-03	4,56E-03	5,02E-03	5,52E-03	6,07E-03	6,68E-03	7,34E-03	8,08E-03	8,89E-03
	POCP	kg NMVOC	1,22E-03	1,35E-03	1,48E-03	1,63E-03	1,79E-03	1,97E-03	2,17E-03	2,38E-03	2,62E-03
	ADPe	kg Sb eq	2,04E-06	2,25E-06	2,47E-06	2,72E-06	2,99E-06	3,29E-06	3,62E-06	3,98E-06	4,38E-06
	ADPf	MJ	3,33E+00	3,67E+00	4,04E+00	4,44E+00	4,88E+00	5,37E+00	5,91E+00	6,50E+00	7,15E+00
	WDP	m3 eq	1,99E-01	2,19E-01	2,40E-01	2,64E-01	2,91E-01	3,20E-01	3,52E-01	3,87E-01	4,26E-01
ODP	kg CFC-11 eq	1,91E-08	2,10E-08	2,31E-08	2,55E-08	2,80E-08	3,08E-08	3,39E-08	3,73E-08	4,10E-08	
A2	GWPf	kg CO2 eq	4,59E-03	5,05E-03	5,55E-03	6,11E-03	6,72E-03	7,39E-03	8,13E-03	8,94E-03	9,83E-03
	GWPb	kg CO2 eq	1,35E-06	1,49E-06	1,64E-06	1,80E-06	1,98E-06	2,18E-06	2,40E-06	2,64E-06	2,90E-06
	GWPI	kg CO2 eq	1,71E-06	1,88E-06	2,07E-06	2,28E-06	2,51E-06	2,76E-06	3,03E-06	3,34E-06	3,67E-06
	GWP	kg CO2 eq	4,59E-03	5,05E-03	5,55E-03	6,11E-03	6,72E-03	7,39E-03	8,13E-03	8,95E-03	9,84E-03
	AP	mol H+ eq	2,35E-05	2,59E-05	2,85E-05	3,13E-05	3,45E-05	3,79E-05	4,17E-05	4,59E-05	5,05E-05
	EPf	kg P eq	2,91E-07	3,20E-07	3,52E-07	3,87E-07	4,26E-07	4,68E-07	5,15E-07	5,67E-07	6,23E-07
	EPm	kg N eq	8,08E-06	8,88E-06	9,77E-06	1,08E-05	1,18E-05	1,30E-05	1,43E-05	1,57E-05	1,73E-05
	EPT	mol N eq	8,84E-05	9,72E-05	1,07E-04	1,18E-04	1,29E-04	1,42E-04	1,57E-04	1,72E-04	1,89E-04
	POCP	kg NMVOC	2,64E-05	2,90E-05	3,19E-05	3,51E-05	3,87E-05	4,25E-05	4,68E-05	5,15E-05	5,66E-05
	ADPe	kg Sb eq	1,07E-08	1,18E-08	1,30E-08	1,43E-08	1,57E-08	1,73E-08	1,90E-08	2,09E-08	2,30E-08
ADPf	MJ	7,14E-02	7,85E-02	8,64E-02	9,50E-02	1,04E-01	1,15E-01	1,26E-01	1,39E-01	1,53E-01	
WDP	m3 depriv.	2,52E-04	2,77E-04	3,05E-04	3,35E-04	3,69E-04	4,06E-04	4,46E-04	4,91E-04	5,40E-04	
ODP	kg CFC-11 eq	8,83E-10	9,71E-10	1,07E-09	1,17E-09	1,29E-09	1,42E-09	1,56E-09	1,72E-09	1,89E-09	
A3	GWPf	kg CO2 eq	1,12E-01	1,23E-01	1,35E-01	1,48E-01	1,63E-01	1,80E-01	1,98E-01	2,17E-01	2,39E-01
	GWPb	kg CO2 eq	3,25E-04	3,57E-04	3,93E-04	4,32E-04	4,75E-04	5,23E-04	5,75E-04	6,32E-04	6,96E-04
	GWPI	kg CO2 eq	2,82E-05	3,10E-05	3,41E-05	3,75E-05	4,13E-05	4,54E-05	4,99E-05	5,49E-05	6,04E-05
	GWP	kg CO2 eq	1,12E-01	1,23E-01	1,35E-01	1,49E-01	1,64E-01	1,80E-01	1,98E-01	2,18E-01	2,40E-01
	AP	mol H+ eq	4,94E-04	5,43E-04	5,97E-04	6,57E-04	7,23E-04	7,95E-04	8,74E-04	9,62E-04	1,06E-03
	EPf	kg P eq	2,52E-05	2,77E-05	3,05E-05	3,35E-05	3,69E-05	4,05E-05	4,46E-05	4,91E-05	5,40E-05
	EPm	kg N eq	8,70E-05	9,57E-05	1,05E-04	1,16E-04	1,27E-04	1,40E-04	1,54E-04	1,70E-04	1,87E-04
	EPT	mol N eq	9,19E-04	1,01E-03	1,11E-03	1,22E-03	1,35E-03	1,48E-03	1,63E-03	1,79E-03	1,97E-03
	POCP	kg NMVOC	2,63E-04	2,89E-04	3,18E-04	3,50E-04	3,85E-04	4,24E-04	4,66E-04	5,13E-04	5,64E-04
	ADPe	kg Sb eq	1,45E-07	1,59E-07	1,75E-07	1,92E-07	2,12E-07	2,33E-07	2,56E-07	2,82E-07	3,10E-07
	ADPf	MJ	1,49E+00	1,64E+00	1,81E+00	1,99E+00	2,19E+00	2,40E+00	2,65E+00	2,91E+00	3,20E+00
WDP	m3 depriv.	3,09E-02	3,40E-02	3,74E-02	4,12E-02	4,53E-02	4,98E-02	5,48E-02	6,03E-02	6,63E-02	
ODP	kg CFC-11 eq	1,31E-08	1,44E-08	1,58E-08	1,74E-08	1,91E-08	2,11E-08	2,32E-08	2,55E-08	2,80E-08	

PHASES	PEI	UM	A	B	C	D	E	F	G	H	I
FASI											
A4	GWPf	kg CO2 eq	3,60E-02	3,95E-02	4,35E-02	4,78E-02	5,26E-02	5,79E-02	6,37E-02	7,01E-02	7,71E-02
	GWPb	kg CO2 eq	9,07E-06	9,98E-06	1,10E-05	1,21E-05	1,33E-05	1,46E-05	1,61E-05	1,77E-05	1,94E-05
	GWPI	kg CO2 eq	1,92E-05	2,11E-05	2,32E-05	2,55E-05	2,81E-05	3,09E-05	3,40E-05	3,74E-05	4,11E-05
	GWP	kg CO2 eq	3,60E-02	3,96E-02	4,35E-02	4,79E-02	5,27E-02	5,79E-02	6,37E-02	7,01E-02	7,71E-02
	AP	mol H+ eq	5,60E-04	6,16E-04	6,78E-04	7,45E-04	8,20E-04	9,02E-04	9,92E-04	1,09E-03	1,20E-03
	EPf	kg P eq	1,98E-06	2,18E-06	2,39E-06	2,63E-06	2,90E-06	3,19E-06	3,50E-06	3,85E-06	4,24E-06
	EPm	kg N eq	1,49E-04	1,64E-04	1,80E-04	1,98E-04	2,18E-04	2,40E-04	2,64E-04	2,90E-04	3,19E-04
	EPT	mol N eq	1,65E-03	1,81E-03	1,99E-03	2,19E-03	2,41E-03	2,65E-03	2,92E-03	3,21E-03	3,53E-03
	POCP	kg NMVOC	4,38E-04	4,82E-04	5,30E-04	5,83E-04	6,41E-04	7,05E-04	7,76E-04	8,53E-04	9,38E-04
	ADPe	kg Sb eq	9,75E-08	1,07E-07	1,18E-07	1,30E-07	1,43E-07	1,57E-07	1,73E-07	1,90E-07	2,09E-07
	ADPf	MJ	5,10E-01	5,60E-01	6,17E-01	6,78E-01	7,46E-01	8,21E-01	9,03E-01	9,93E-01	1,09E+00
	WDP	m3 depriv.	1,38E-03	1,52E-03	1,67E-03	1,84E-03	2,03E-03	2,23E-03	2,45E-03	2,70E-03	2,97E-03
ODP	kg CFC-11 eq	6,25E-09	6,87E-09	7,56E-09	8,32E-09	9,15E-09	1,01E-08	1,11E-08	1,22E-08	1,34E-08	
C1	GWPf	kg CO2 eq	0,00E+00	0,00E+00	0,00E+00	0,00E+00	0,00E+00	0,00E+00	0,00E+00	0,00E+00	0,00E+00
	GWPb	kg CO2 eq	0,00E+00	0,00E+00	0,00E+00	0,00E+00	0,00E+00	0,00E+00	0,00E+00	0,00E+00	0,00E+00
	GWPI	kg CO2 eq	0,00E+00	0,00E+00	0,00E+00	0,00E+00	0,00E+00	0,00E+00	0,00E+00	0,00E+00	0,00E+00
	GWP	kg CO2 eq	0,00E+00	0,00E+00	0,00E+00	0,00E+00	0,00E+00	0,00E+00	0,00E+00	0,00E+00	0,00E+00
	AP	mol H+ eq	0,00E+00	0,00E+00	0,00E+00	0,00E+00	0,00E+00	0,00E+00	0,00E+00	0,00E+00	0,00E+00
	EPf	kg P eq	0,00E+00	0,00E+00	0,00E+00	0,00E+00	0,00E+00	0,00E+00	0,00E+00	0,00E+00	0,00E+00
	EPm	kg N eq	0,00E+00	0,00E+00	0,00E+00	0,00E+00	0,00E+00	0,00E+00	0,00E+00	0,00E+00	0,00E+00
	EPT	mol N eq	0,00E+00	0,00E+00	0,00E+00	0,00E+00	0,00E+00	0,00E+00	0,00E+00	0,00E+00	0,00E+00
	POCP	kg NMVOC	0,00E+00	0,00E+00	0,00E+00	0,00E+00	0,00E+00	0,00E+00	0,00E+00	0,00E+00	0,00E+00
	ADPe	kg Sb eq	0,00E+00	0,00E+00	0,00E+00	0,00E+00	0,00E+00	0,00E+00	0,00E+00	0,00E+00	0,00E+00
	ADPf	MJ	0,00E+00	0,00E+00	0,00E+00	0,00E+00	0,00E+00	0,00E+00	0,00E+00	0,00E+00	0,00E+00
	WDP	m3 depriv.	0,00E+00	0,00E+00	0,00E+00	0,00E+00	0,00E+00	0,00E+00	0,00E+00	0,00E+00	0,00E+00
ODP	kg CFC-11 eq	0,00E+00	0,00E+00	0,00E+00	0,00E+00	0,00E+00	0,00E+00	0,00E+00	0,00E+00	0,00E+00	
C2	GWPf	kg CO2 eq	6,90E-03	7,59E-03	8,35E-03	9,18E-03	1,01E-02	1,11E-02	1,22E-02	1,34E-02	1,48E-02
	GWPb	kg CO2 eq	1,91E-06	2,10E-06	2,31E-06	2,54E-06	2,80E-06	3,08E-06	3,38E-06	3,72E-06	4,09E-06
	GWPI	kg CO2 eq	2,98E-06	3,28E-06	3,61E-06	3,97E-06	4,36E-06	4,80E-06	5,28E-06	5,81E-06	6,39E-06
	GWP	kg CO2 eq	6,90E-03	7,59E-03	8,35E-03	9,19E-03	1,01E-02	1,11E-02	1,22E-02	1,34E-02	1,48E-02
	AP	mol H+ eq	3,54E-05	3,89E-05	4,28E-05	4,71E-05	5,18E-05	5,70E-05	6,27E-05	6,90E-05	7,59E-05
	EPf	kg P eq	5,24E-07	5,77E-07	6,35E-07	6,98E-07	7,68E-07	8,45E-07	9,29E-07	1,02E-06	1,12E-06
	EPm	kg N eq	1,20E-05	1,32E-05	1,45E-05	1,59E-05	1,75E-05	1,93E-05	2,12E-05	2,33E-05	2,57E-05
	EPT	mol N eq	1,31E-04	1,44E-04	1,58E-04	1,74E-04	1,92E-04	2,11E-04	2,32E-04	2,55E-04	2,81E-04
	POCP	kg NMVOC	3,73E-05	4,10E-05	4,51E-05	4,96E-05	5,46E-05	6,00E-05	6,60E-05	7,26E-05	7,99E-05
	ADPe	kg Sb eq	2,40E-08	2,63E-08	2,90E-08	3,19E-08	3,51E-08	3,86E-08	4,24E-08	4,67E-08	5,13E-08
	ADPf	MJ	1,02E-01	1,12E-01	1,24E-01	1,36E-01	1,50E-01	1,65E-01	1,81E-01	1,99E-01	2,19E-01
	WDP	m3 depriv.	3,61E-04	3,97E-04	4,37E-04	4,80E-04	5,28E-04	5,81E-04	6,39E-04	7,03E-04	7,73E-04
ODP	kg CFC-11 eq	1,20E-09	1,32E-09	1,45E-09	1,60E-09	1,76E-09	1,93E-09	2,13E-09	2,34E-09	2,57E-09	

Environmental performance of Sherwood and Soundwood Panels, thickness 15 mm – Use of resources

Performance ambientali dei pannelli Sherwood and Soundwood, spessore 15 mm – Consumo di risorse

Class legend – Material and weight class (kg)

Legenda Classi – Materiale e Classe di peso (Kg)

A:	<i>Sherwood and Soundwood panels, fire resistant MDF</i>	<i>5,15<p<5,66</i>
B:	<i>Sherwood and Soundwood panels, fire resistant MDF</i>	<i>5,66<p<6,23</i>
C:	<i>Sherwood and Soundwood panels, fire resistant MDF</i>	<i>6,23<p<6,85</i>
D:	<i>Sherwood and Soundwood panels, fire resistant MDF</i>	<i>6,85<p<7,53</i>
E:	<i>Sherwood and Soundwood panels, fire resistant MDF</i>	<i>7,53<p<8,29</i>
F:	<i>Sherwood and Soundwood panels, fire resistant MDF</i>	<i>8,29<p<9,11</i>
G:	<i>Sherwood and Soundwood panels, fire resistant MDF</i>	<i>9,11<p<10,03</i>
H:	<i>Sherwood and Soundwood panels, fire resistant MDF</i>	<i>10,03 <p<11,03</i>
I:	<i>Sherwood and Soundwood panels, fire resistant MDF</i>	<i>11,03 <p<12,13</i>

Legend – Potential environmental impact:

Legenda impatti:

PEI Potential environment impact

UM Unit of measure

GWP	Global warming potential, total
GWPf	Global warming potential, fossil
GWPb	Global warming potential, biogenic
GWPI	Global warming potential, land use
ODP	Ozone depletion potential
AP	Acidification potential of land and water
EPf	Eutrophication aquatic, freshwater
EPm	Eutrophication aquatic, marine
EPT	Eutrophication aquatic, terrestrial
POCP	Photochemical ozone creation potential
ADPe	Abiotic depletion potential, elements
ADPf	Abiotic depletion potential, fossil
WDP	Water depletion potential

Functional Unit: 1 m² of ceiling/wall covering

Unità funzionale: 1 m² di controsoffitto/rivestimento

PHASES FASI	PEI	UM	A	B	C	D	E	F	G	H	I
	<i>RSF</i>	<i>MJ</i>	0,00E+00	0,00E+00	0,00E+00	0,00E+00	0,00E+00	0,00E+00	0,00E+00	0,00E+00	0,00E+00
	<i>NRSF</i>	<i>MJ</i>	0,00E+00	0,00E+00	0,00E+00	0,00E+00	0,00E+00	0,00E+00	0,00E+00	0,00E+00	0,00E+00
	<i>FW</i>	<i>m3</i>	3,69E-04	4,06E-04	4,47E-04	4,91E-04	5,41E-04	5,95E-04	6,54E-04	7,20E-04	7,92E-04
C1	<i>PERE</i>	<i>MJ</i>	0,00E+00	0,00E+00	0,00E+00	0,00E+00	0,00E+00	0,00E+00	0,00E+00	0,00E+00	0,00E+00
	<i>PERM</i>	<i>MJ</i>	0,00E+00	0,00E+00	0,00E+00	0,00E+00	0,00E+00	0,00E+00	0,00E+00	0,00E+00	0,00E+00
	<i>PERT</i>	<i>MJ</i>	0,00E+00	0,00E+00	0,00E+00	0,00E+00	0,00E+00	0,00E+00	0,00E+00	0,00E+00	0,00E+00
	<i>PENRE</i>	<i>MJ</i>	0,00E+00	0,00E+00	0,00E+00	0,00E+00	0,00E+00	0,00E+00	0,00E+00	0,00E+00	0,00E+00
	<i>PENRM</i>	<i>MJ</i>	0,00E+00	0,00E+00	0,00E+00	0,00E+00	0,00E+00	0,00E+00	0,00E+00	0,00E+00	0,00E+00
	<i>PENRT</i>	<i>MJ</i>	0,00E+00	0,00E+00	0,00E+00	0,00E+00	0,00E+00	0,00E+00	0,00E+00	0,00E+00	0,00E+00
	<i>SM</i>	<i>kg</i>	0,00E+00	0,00E+00	0,00E+00	0,00E+00	0,00E+00	0,00E+00	0,00E+00	0,00E+00	0,00E+00
	<i>RSF</i>	<i>MJ</i>	0,00E+00	0,00E+00	0,00E+00	0,00E+00	0,00E+00	0,00E+00	0,00E+00	0,00E+00	0,00E+00
	<i>NRSF</i>	<i>MJ</i>	0,00E+00	0,00E+00	0,00E+00	0,00E+00	0,00E+00	0,00E+00	0,00E+00	0,00E+00	0,00E+00
	<i>FW</i>	<i>m3</i>	0,00E+00	0,00E+00	0,00E+00	0,00E+00	0,00E+00	0,00E+00	0,00E+00	0,00E+00	0,00E+00
C2	<i>PERE</i>	<i>MJ</i>	8,45E-04	9,29E-04	1,02E-03	1,12E-03	1,24E-03	1,36E-03	1,50E-03	1,65E-03	1,81E-03
	<i>PERM</i>	<i>MJ</i>	3,52E-04	3,88E-04	4,27E-04	4,69E-04	5,16E-04	5,68E-04	6,24E-04	6,87E-04	7,56E-04
	<i>PERT</i>	<i>MJ</i>	1,20E-03	1,32E-03	1,45E-03	1,59E-03	1,75E-03	1,93E-03	2,12E-03	2,33E-03	2,57E-03
	<i>PENRE</i>	<i>MJ</i>	1,02E-01	1,12E-01	1,24E-01	1,36E-01	1,50E-01	1,65E-01	1,81E-01	1,99E-01	2,19E-01
	<i>PENRM</i>	<i>MJ</i>	0,00E+00	0,00E+00	0,00E+00	0,00E+00	0,00E+00	0,00E+00	0,00E+00	0,00E+00	0,00E+00
	<i>PENRT</i>	<i>MJ</i>	1,02E-01	1,12E-01	1,24E-01	1,36E-01	1,50E-01	1,65E-01	1,81E-01	1,99E-01	2,19E-01
	<i>SM</i>	<i>kg</i>	0,00E+00	0,00E+00	0,00E+00	0,00E+00	0,00E+00	0,00E+00	0,00E+00	0,00E+00	0,00E+00
	<i>RSF</i>	<i>MJ</i>	0,00E+00	0,00E+00	0,00E+00	0,00E+00	0,00E+00	0,00E+00	0,00E+00	0,00E+00	0,00E+00
	<i>NRSF</i>	<i>MJ</i>	0,00E+00	0,00E+00	0,00E+00	0,00E+00	0,00E+00	0,00E+00	0,00E+00	0,00E+00	0,00E+00
	<i>FW</i>	<i>m3</i>	8,35E-05	9,19E-05	1,01E-04	1,11E-04	1,22E-04	1,34E-04	1,48E-04	1,63E-04	1,79E-04
C3	<i>PERE</i>	<i>MJ</i>	0,00E+00	0,00E+00	0,00E+00	0,00E+00	0,00E+00	0,00E+00	0,00E+00	0,00E+00	0,00E+00
	<i>PERM</i>	<i>MJ</i>	0,00E+00	0,00E+00	0,00E+00	0,00E+00	0,00E+00	0,00E+00	0,00E+00	0,00E+00	0,00E+00
	<i>PERT</i>	<i>MJ</i>	0,00E+00	0,00E+00	0,00E+00	0,00E+00	0,00E+00	0,00E+00	0,00E+00	0,00E+00	0,00E+00
	<i>PENRE</i>	<i>MJ</i>	0,00E+00	0,00E+00	0,00E+00	0,00E+00	0,00E+00	0,00E+00	0,00E+00	0,00E+00	0,00E+00
	<i>PENRM</i>	<i>MJ</i>	0,00E+00	0,00E+00	0,00E+00	0,00E+00	0,00E+00	0,00E+00	0,00E+00	0,00E+00	0,00E+00
	<i>PENRT</i>	<i>MJ</i>	0,00E+00	0,00E+00	0,00E+00	0,00E+00	0,00E+00	0,00E+00	0,00E+00	0,00E+00	0,00E+00
	<i>SM</i>	<i>kg</i>	0,00E+00	0,00E+00	0,00E+00	0,00E+00	0,00E+00	0,00E+00	0,00E+00	0,00E+00	0,00E+00
	<i>RSF</i>	<i>MJ</i>	0,00E+00	0,00E+00	0,00E+00	0,00E+00	0,00E+00	0,00E+00	0,00E+00	0,00E+00	0,00E+00
	<i>NRSF</i>	<i>MJ</i>	0,00E+00	0,00E+00	0,00E+00	0,00E+00	0,00E+00	0,00E+00	0,00E+00	0,00E+00	0,00E+00
	<i>FW</i>	<i>m3</i>	0,00E+00	0,00E+00	0,00E+00	0,00E+00	0,00E+00	0,00E+00	0,00E+00	0,00E+00	0,00E+00
C4	<i>PERE</i>	<i>MJ</i>	7,65E-04	8,41E-04	9,26E-04	1,02E-03	1,12E-03	1,23E-03	1,36E-03	1,49E-03	1,64E-03
	<i>PERM</i>	<i>MJ</i>	2,93E-04	3,23E-04	3,55E-04	3,91E-04	4,30E-04	4,73E-04	5,20E-04	5,72E-04	6,29E-04
	<i>PERT</i>	<i>MJ</i>	1,06E-03	1,16E-03	1,28E-03	1,41E-03	1,55E-03	1,70E-03	1,88E-03	2,06E-03	2,27E-03
	<i>PENRE</i>	<i>MJ</i>	5,05E-02	5,55E-02	6,11E-02	6,72E-02	7,39E-02	8,13E-02	8,94E-02	9,83E-02	1,08E-01

Environmental performance of Sherwood and Soundwood Panels, thickness 15 mm - Waste production and output flows

Performance ambientali dei pannelli Sherwood and Soundwood, spessore 15 mm - Produzione di rifiuti e flussi in output

Class legend – Material and weight class (kg)

Legenda Classi – Materiale e Classe di peso (Kg)

A:	<i>Sherwood and Soundwood panels, fire resistant MDF</i>	<i>5,15<p<5,66</i>
B:	<i>Sherwood and Soundwood panels, fire resistant MDF</i>	<i>5,66<p<6,23</i>
C:	<i>Sherwood and Soundwood panels, fire resistant MDF</i>	<i>6,23<p<6,85</i>
D:	<i>Sherwood and Soundwood panels, fire resistant MDF</i>	<i>6,85<p<7,53</i>
E:	<i>Sherwood and Soundwood panels, fire resistant MDF</i>	<i>7,53<p<8,29</i>
F:	<i>Sherwood and Soundwood panels, fire resistant MDF</i>	<i>8,29<p<9,11</i>
G:	<i>Sherwood and Soundwood panels, fire resistant MDF</i>	<i>9,11<p<10,03</i>
H:	<i>Sherwood and Soundwood panels, fire resistant MDF</i>	<i>10,03 <p<11,03</i>
I:	<i>Sherwood and Soundwood panels, fire resistant MDF</i>	<i>11,03 <p<12,13</i>

Legend – Potential environmental impact:

Legenda impatti:

PEI Potential environment impact

UM Unit of measure

GWP	Global warming potential, total
GWPf	Global warming potential, fossil
GWPb	Global warming potential, biogenic
GWPI	Global warming potential, land use
ODP	Ozone depletion potential
AP	Acidification potential of land and water
EPf	Eutrophication aquatic, freshwater
EPm	Eutrophication aquatic, marine
EPT	Eutrophication aquatic, terrestrial
POCP	Photochemical ozone creation potential
ADPe	Abiotic depletion potential, elements
ADPf	Abiotic depletion potential, fossil
WDP	Water depletion potential

Functional Unit: 1 m² of ceiling/wall covering

Unità funzionale: 1 m² di controsoffitto/rivestimento

Environmental performance of Acoustik Plus Panels, thickness 14 mm - Impact *Performance ambientali dei pannelli Acoustik Plus, spessore 14 mm - Impatti*

Class legend – Material and weight class (kg)

Legenda Classi – Materiale e Classe di peso (Kg)

A:	Acoustik Plus panels, fire -proof plaster fireboard	9,03 <p<9,93
B:	Acoustik Plus panels, fire -proof plaster fireboard	9,93<p<10,92
C:	Acoustik Plus panels, fire -proof plaster fireboard	10,92<p<12,02
D:	Acoustik Plus panels, fire -proof plaster fireboard	12,02<p<13,22
E:	Acoustik Plus panels, fire -proof plaster fireboard	13,22<p<14,54
F:	Acoustik Plus panels, fire -proof plaster fireboard	14,54<p<15,99

Legend – Potential environmental impact:

Legenda impatti:

PEI Potential environment impact

UM Unit of measure

GWP	Global warming potential, total
GWPf	Global warming potential, fossil
GWPb	Global warming potential, biogenic
GWPI	Global warming potential, land use
ODP	Ozone depletion potential
AP	Acidification potential of land and water
EPf	Eutrophication aquatic, freshwater
EPm	Eutrophication aquatic, marine
EPT	Eutrophication aquatic, terrestrial
POCP	Photochemical ozone creation potential
ADPe	Abiotic depletion potential, elements
ADPf	Abiotic depletion potential, fossil
WDP	Water depletion potential

Functional Unit: 1 m² of ceiling/wall covering

Unità funzionale: 1 m² di
controsoffitto/rivestimento

PHASES FASI	PEI	UM	A	B	C	D	E	F
A1	GWPf	kg CO2 eq	6,28E-02	6,91E-02	7,60E-02	8,36E-02	9,20E-02	1,01E-01
	GWPb	kg CO2 eq	1,63E-03	1,80E-03	1,98E-03	2,17E-03	2,39E-03	2,63E-03
	GWPI	kg CO2 eq	2,23E-04	2,45E-04	2,70E-04	2,97E-04	3,27E-04	3,59E-04
	GWP	kg CO2 eq	6,47E-02	7,12E-02	7,83E-02	8,61E-02	9,47E-02	1,04E-01
	AP	mol H+ eq	4,13E-04	4,54E-04	4,99E-04	5,49E-04	6,04E-04	6,64E-04
	EPf	kg P eq	1,97E-05	2,17E-05	2,38E-05	2,62E-05	2,88E-05	3,17E-05
	EPm	kg N eq	1,41E-04	1,55E-04	1,71E-04	1,88E-04	2,06E-04	2,27E-04
	EPt	mol N eq	1,22E-03	1,34E-03	1,48E-03	1,62E-03	1,79E-03	1,97E-03
	POCP	kg NMVOC	2,84E-04	3,12E-04	3,43E-04	3,78E-04	4,15E-04	4,57E-04
	ADPe	kg Sb eq	2,93E-07	3,22E-07	3,54E-07	3,90E-07	4,29E-07	4,71E-07
	ADPf	MJ	8,02E-01	8,82E-01	9,70E-01	1,07E+00	1,17E+00	1,29E+00
	WDP	m3 eq	2,24E-02	2,47E-02	2,71E-02	2,98E-02	3,28E-02	3,61E-02
	ODP	kg CFC-11 eq	6,35E-09	6,99E-09	7,68E-09	8,45E-09	9,30E-09	1,02E-08
A2	GWPf	kg CO2 eq	1,37E-01	1,51E-01	1,66E-01	1,83E-01	2,01E-01	2,21E-01
	GWPb	kg CO2 eq	4,04E-05	4,45E-05	4,89E-05	5,38E-05	5,92E-05	6,51E-05
	GWPI	kg CO2 eq	5,14E-05	5,65E-05	6,22E-05	6,84E-05	7,52E-05	8,27E-05
	GWP	kg CO2 eq	1,37E-01	1,51E-01	1,66E-01	1,83E-01	2,01E-01	2,21E-01
	AP	mol H+ eq	7,14E-04	7,86E-04	8,65E-04	9,51E-04	1,05E-03	1,15E-03
	EPf	kg P eq	8,69E-06	9,55E-06	1,05E-05	1,16E-05	1,27E-05	1,40E-05
	EPm	kg N eq	2,44E-04	2,68E-04	2,95E-04	3,25E-04	3,57E-04	3,93E-04
	EPt	mol N eq	2,67E-03	2,94E-03	3,23E-03	3,55E-03	3,91E-03	4,30E-03
	POCP	kg NMVOC	7,96E-04	8,76E-04	9,63E-04	1,06E-03	1,17E-03	1,28E-03
	ADPe	kg Sb eq	3,20E-07	3,52E-07	3,87E-07	4,26E-07	4,69E-07	5,15E-07
	ADPf	MJ	2,13E+00	2,35E+00	2,58E+00	2,84E+00	3,12E+00	3,44E+00
	WDP	m3 depriv.	7,52E-03	8,27E-03	9,10E-03	1,00E-02	1,10E-02	1,21E-02
	ODP	kg CFC-11 eq	2,64E-08	2,90E-08	3,19E-08	3,51E-08	3,86E-08	4,25E-08
A3	GWPf	kg CO2 eq	1,96E-01	2,15E-01	2,37E-01	2,61E-01	2,87E-01	3,15E-01
	GWPb	kg CO2 eq	5,69E-04	6,26E-04	6,89E-04	7,58E-04	8,34E-04	9,17E-04
	GWPI	kg CO2 eq	4,94E-05	5,44E-05	5,98E-05	6,58E-05	7,24E-05	7,96E-05
	GWP	kg CO2 eq	1,96E-01	2,16E-01	2,38E-01	2,61E-01	2,88E-01	3,16E-01
	AP	mol H+ eq	8,66E-04	9,53E-04	1,05E-03	1,15E-03	1,27E-03	1,39E-03
	EPf	kg P eq	4,42E-05	4,86E-05	5,34E-05	5,88E-05	6,47E-05	7,11E-05
	EPm	kg N eq	1,53E-04	1,68E-04	1,85E-04	2,03E-04	2,24E-04	2,46E-04
	EPt	mol N eq	1,61E-03	1,77E-03	1,95E-03	2,15E-03	2,36E-03	2,60E-03
	POCP	kg NMVOC	4,62E-04	5,08E-04	5,59E-04	6,14E-04	6,76E-04	7,44E-04
	ADPe	kg Sb eq	2,54E-07	2,79E-07	3,07E-07	3,38E-07	3,71E-07	4,09E-07
	ADPf	MJ	2,62E+00	2,88E+00	3,17E+00	3,49E+00	3,84E+00	4,22E+00

PHASES FASI	PEI	UM	A	B	C	D	E	F
	WDP	m3 depriv.	5,43E-02	5,97E-02	6,57E-02	7,23E-02	7,95E-02	8,74E-02
	ODP	kg CFC-11 eq	2,30E-08	2,52E-08	2,78E-08	3,05E-08	3,36E-08	3,70E-08
A4	GWPf	kg CO2 eq	6,31E-02	6,94E-02	7,63E-02	8,40E-02	9,24E-02	1,02E-01
	GWPb	kg CO2 eq	1,59E-05	1,75E-05	1,93E-05	2,12E-05	2,33E-05	2,56E-05
	GWPI	kg CO2 eq	3,37E-05	3,70E-05	4,08E-05	4,48E-05	4,93E-05	5,42E-05
	GWP	kg CO2 eq	6,31E-02	6,94E-02	7,64E-02	8,40E-02	9,24E-02	1,02E-01
	AP	mol H+ eq	9,83E-04	1,08E-03	1,19E-03	1,31E-03	1,44E-03	1,58E-03
	EPf	kg P eq	3,47E-06	3,82E-06	4,20E-06	4,62E-06	5,08E-06	5,59E-06
	EPm	kg N eq	2,61E-04	2,87E-04	3,16E-04	3,48E-04	3,82E-04	4,21E-04
	EPt	mol N eq	2,89E-03	3,18E-03	3,50E-03	3,85E-03	4,23E-03	4,65E-03
	POCP	kg NMVOC	7,68E-04	8,45E-04	9,29E-04	1,02E-03	1,12E-03	1,24E-03
	ADPe	kg Sb eq	1,71E-07	1,88E-07	2,07E-07	2,28E-07	2,51E-07	2,76E-07
	ADPf	MJ	8,94E-01	9,84E-01	1,08E+00	1,19E+00	1,31E+00	1,44E+00
	WDP	m3 depriv.	2,43E-03	2,67E-03	2,94E-03	3,23E-03	3,55E-03	3,91E-03
	ODP	kg CFC-11 eq	1,10E-08	1,21E-08	1,33E-08	1,46E-08	1,61E-08	1,77E-08
	C1	GWPf	kg CO2 eq	0,00E+00	0,00E+00	0,00E+00	0,00E+00	0,00E+00
GWPb		kg CO2 eq	0,00E+00	0,00E+00	0,00E+00	0,00E+00	0,00E+00	0,00E+00
GWPI		kg CO2 eq	0,00E+00	0,00E+00	0,00E+00	0,00E+00	0,00E+00	0,00E+00
GWP		kg CO2 eq	0,00E+00	0,00E+00	0,00E+00	0,00E+00	0,00E+00	0,00E+00
AP		mol H+ eq	0,00E+00	0,00E+00	0,00E+00	0,00E+00	0,00E+00	0,00E+00
EPf		kg P eq	0,00E+00	0,00E+00	0,00E+00	0,00E+00	0,00E+00	0,00E+00
EPm		kg N eq	0,00E+00	0,00E+00	0,00E+00	0,00E+00	0,00E+00	0,00E+00
EPt		mol N eq	0,00E+00	0,00E+00	0,00E+00	0,00E+00	0,00E+00	0,00E+00
POCP		kg NMVOC	0,00E+00	0,00E+00	0,00E+00	0,00E+00	0,00E+00	0,00E+00
ADPe		kg Sb eq	0,00E+00	0,00E+00	0,00E+00	0,00E+00	0,00E+00	0,00E+00
ADPf		MJ	0,00E+00	0,00E+00	0,00E+00	0,00E+00	0,00E+00	0,00E+00
WDP		m3 depriv.	0,00E+00	0,00E+00	0,00E+00	0,00E+00	0,00E+00	0,00E+00
ODP		kg CFC-11 eq	0,00E+00	0,00E+00	0,00E+00	0,00E+00	0,00E+00	0,00E+00
C2		GWPf	kg CO2 eq	1,21E-02	1,33E-02	1,46E-02	1,61E-02	1,77E-02
	GWPb	kg CO2 eq	3,35E-06	3,69E-06	4,06E-06	4,46E-06	4,91E-06	5,40E-06
	GWPI	kg CO2 eq	5,23E-06	5,75E-06	6,33E-06	6,96E-06	7,66E-06	8,43E-06
	GWP	kg CO2 eq	1,21E-02	1,33E-02	1,47E-02	1,61E-02	1,77E-02	1,95E-02
	AP	mol H+ eq	6,21E-05	6,83E-05	7,51E-05	8,26E-05	9,09E-05	1,00E-04
	EPf	kg P eq	9,20E-07	1,01E-06	1,11E-06	1,22E-06	1,35E-06	1,48E-06
	EPm	kg N eq	2,10E-05	2,31E-05	2,54E-05	2,80E-05	3,08E-05	3,38E-05
	EPt	mol N eq	2,30E-04	2,53E-04	2,78E-04	3,06E-04	3,36E-04	3,70E-04
	POCP	kg NMVOC	6,54E-05	7,19E-05	7,91E-05	8,70E-05	9,57E-05	1,05E-04

Environmental performance of Acoustik Plus Panels, thickness 14 mm – Use of resources *Performance ambientali dei pannelli Acoustik Plus, spessore 14 mm – Consumo di risorse*

Class legend – Material and weight class (kg)

Legenda Classi – Materiale e Classe di peso (Kg)

A:	Acoustik Plus panels, fire -proof plaster fireboard	9,03 <p<9,93
B:	Acoustik Plus panels, fire -proof plaster fireboard	9,93<p<10,92
C:	Acoustik Plus panels, fire -proof plaster fireboard	10,92<p<12,02
D:	Acoustik Plus panels, fire -proof plaster fireboard	12,02<p<13,22
E:	Acoustik Plus panels, fire -proof plaster fireboard	13,22<p<14,54
F:	Acoustik Plus panels, fire -proof plaster fireboard	14,54<p<15,99

Legend – Potential environmental impact:

Legenda impatti:

PEI Potential environment impact

UM Unit of measure

GWP	Global warming potential, total
GWPf	Global warming potential, fossil
GWPb	Global warming potential, biogenic
GWPI	Global warming potential, land use
ODP	Ozone depletion potential
AP	Acidification potential of land and water
EPf	Eutrophication aquatic, freshwater
EPm	Eutrophication aquatic, marine
EPT	Eutrophication aquatic, terrestrial
POCP	Photochemical ozone creation potential
ADPe	Abiotic depletion potential, elements
ADPf	Abiotic depletion potential, fossil
WDP	Water depletion potential

Functional Unit: 1 m² of ceiling/wall covering

Unità funzionale: 1 m² di controsoffitto/rivestimento

PHASES FASI	PEI	UM	A	B	C	D	E	F
	<i>RSF</i>	<i>MJ</i>	0,00E+00	0,00E+00	0,00E+00	0,00E+00	0,00E+00	0,00E+00
	<i>NRSF</i>	<i>MJ</i>	0,00E+00	0,00E+00	0,00E+00	0,00E+00	0,00E+00	0,00E+00
	<i>FW</i>	<i>m3</i>	6,48E-04	7,13E-04	7,84E-04	8,62E-04	9,49E-04	1,04E-03
C1	<i>PERE</i>	<i>MJ</i>	0,00E+00	0,00E+00	0,00E+00	0,00E+00	0,00E+00	0,00E+00
	<i>PERM</i>	<i>MJ</i>	0,00E+00	0,00E+00	0,00E+00	0,00E+00	0,00E+00	0,00E+00
	<i>PERT</i>	<i>MJ</i>	0,00E+00	0,00E+00	0,00E+00	0,00E+00	0,00E+00	0,00E+00
	<i>PENRE</i>	<i>MJ</i>	0,00E+00	0,00E+00	0,00E+00	0,00E+00	0,00E+00	0,00E+00
	<i>PENRM</i>	<i>MJ</i>	0,00E+00	0,00E+00	0,00E+00	0,00E+00	0,00E+00	0,00E+00
	<i>PENRT</i>	<i>MJ</i>	0,00E+00	0,00E+00	0,00E+00	0,00E+00	0,00E+00	0,00E+00
	<i>SM</i>	<i>kg</i>	0,00E+00	0,00E+00	0,00E+00	0,00E+00	0,00E+00	0,00E+00
	<i>RSF</i>	<i>MJ</i>	0,00E+00	0,00E+00	0,00E+00	0,00E+00	0,00E+00	0,00E+00
	<i>NRSF</i>	<i>MJ</i>	0,00E+00	0,00E+00	0,00E+00	0,00E+00	0,00E+00	0,00E+00
	<i>FW</i>	<i>m3</i>	0,00E+00	0,00E+00	0,00E+00	0,00E+00	0,00E+00	0,00E+00
C2	<i>PERE</i>	<i>MJ</i>	1,48E-03	1,63E-03	1,79E-03	1,97E-03	2,17E-03	2,39E-03
	<i>PERM</i>	<i>MJ</i>	6,18E-04	6,80E-04	7,48E-04	8,23E-04	9,05E-04	9,96E-04
	<i>PERT</i>	<i>MJ</i>	2,10E-03	2,31E-03	2,54E-03	2,80E-03	3,08E-03	3,38E-03
	<i>PENRE</i>	<i>MJ</i>	1,79E-01	1,97E-01	2,17E-01	2,39E-01	2,63E-01	2,89E-01
	<i>PENRM</i>	<i>MJ</i>	0,00E+00	0,00E+00	0,00E+00	0,00E+00	0,00E+00	0,00E+00
	<i>PENRT</i>	<i>MJ</i>	1,79E-01	1,97E-01	2,17E-01	2,39E-01	2,63E-01	2,89E-01
	<i>SM</i>	<i>kg</i>	0,00E+00	0,00E+00	0,00E+00	0,00E+00	0,00E+00	0,00E+00
	<i>RSF</i>	<i>MJ</i>	0,00E+00	0,00E+00	0,00E+00	0,00E+00	0,00E+00	0,00E+00
	<i>NRSF</i>	<i>MJ</i>	0,00E+00	0,00E+00	0,00E+00	0,00E+00	0,00E+00	0,00E+00
	<i>FW</i>	<i>m3</i>	1,47E-04	1,61E-04	1,77E-04	1,95E-04	2,15E-04	2,36E-04
C3	<i>PERE</i>	<i>MJ</i>	0,00E+00	0,00E+00	0,00E+00	0,00E+00	0,00E+00	0,00E+00
	<i>PERM</i>	<i>MJ</i>	0,00E+00	0,00E+00	0,00E+00	0,00E+00	0,00E+00	0,00E+00
	<i>PERT</i>	<i>MJ</i>	0,00E+00	0,00E+00	0,00E+00	0,00E+00	0,00E+00	0,00E+00
	<i>PENRE</i>	<i>MJ</i>	0,00E+00	0,00E+00	0,00E+00	0,00E+00	0,00E+00	0,00E+00
	<i>PENRM</i>	<i>MJ</i>	0,00E+00	0,00E+00	0,00E+00	0,00E+00	0,00E+00	0,00E+00
	<i>PENRT</i>	<i>MJ</i>	0,00E+00	0,00E+00	0,00E+00	0,00E+00	0,00E+00	0,00E+00
	<i>SM</i>	<i>kg</i>	0,00E+00	0,00E+00	0,00E+00	0,00E+00	0,00E+00	0,00E+00
	<i>RSF</i>	<i>MJ</i>	0,00E+00	0,00E+00	0,00E+00	0,00E+00	0,00E+00	0,00E+00
	<i>NRSF</i>	<i>MJ</i>	0,00E+00	0,00E+00	0,00E+00	0,00E+00	0,00E+00	0,00E+00
	<i>FW</i>	<i>m3</i>	0,00E+00	0,00E+00	0,00E+00	0,00E+00	0,00E+00	0,00E+00
C4	<i>PERE</i>	<i>MJ</i>	4,07E-04	4,48E-04	4,93E-04	5,42E-04	5,96E-04	6,56E-04
	<i>PERM</i>	<i>MJ</i>	2,04E-04	2,24E-04	2,47E-04	2,71E-04	2,98E-04	3,28E-04
	<i>PERT</i>	<i>MJ</i>	6,11E-04	6,72E-04	7,39E-04	8,13E-04	8,94E-04	9,84E-04
	<i>PENRE</i>	<i>MJ</i>	6,85E-02	7,53E-02	8,29E-02	9,11E-02	1,00E-01	1,10E-01

Environmental performance of Acoustik Plus Panels, thickness 14 mm - Waste production and output flows

Performance ambientali dei pannelli Acoustik Plus, spessore 14 mm - Produzione di rifiuti e flussi in output

Class legend – Material and weight class (kg)

Legenda Classi – Materiale e Classe di peso (Kg)

A:	Acoustik Plus panels, fire -proof plaster fireboard	9,03 <p<9,93
B:	Acoustik Plus panels, fire -proof plaster fireboard	9,93<p<10,92
C:	Acoustik Plus panels, fire -proof plaster fireboard	10,92<p<12,02
D:	Acoustik Plus panels, fire -proof plaster fireboard	12,02<p<13,22
E:	Acoustik Plus panels, fire -proof plaster fireboard	13,22<p<14,54
F:	Acoustik Plus panels, fire -proof plaster fireboard	14,54<p<15,99

Legend – Potential environmental impact:

Legenda impatti:

PEI Potential environment impact

UM Unit of measure

GWP	Global warming potential, total
GWPf	Global warming potential, fossil
GWPb	Global warming potential, biogenic
GWPI	Global warming potential, land use
ODP	Ozone depletion potential
AP	Acidification potential of land and water
EPf	Eutrophication aquatic, freshwater
EPm	Eutrophication aquatic, marine
EPT	Eutrophication aquatic, terrestrial
POCP	Photochemical ozone creation potential
ADPe	Abiotic depletion potential, elements
ADPf	Abiotic depletion potential, fossil
WDP	Water depletion potential

Functional Unit: 1 m² of ceiling/wall covering

Unità funzionale: 1 m² di controsoffitto/rivestimento

PHASES FASI	WASTE RIFIUTI	UM	A	B	C	D	E	F
A1	HWD	kg	1,81E-06	1,99E-06	2,19E-06	2,41E-06	2,65E-06	2,92E-06
	NHWD	kg	1,51E-02	1,66E-02	1,82E-02	2,01E-02	2,21E-02	2,43E-02
	RWD	kg	4,72E-06	5,19E-06	5,71E-06	6,28E-06	6,90E-06	7,59E-06
A2	HWD	kg	5,26E-06	5,78E-06	6,36E-06	6,99E-06	7,69E-06	0,00E+00
	NHWD	kg	2,03E-01	2,24E-01	2,46E-01	2,71E-01	2,98E-01	0,00E+00
	RWD	kg	1,47E-05	1,62E-05	1,78E-05	1,96E-05	2,16E-05	0,00E+00
A3	HWD	kg	3,81E-06	4,20E-06	4,62E-06	5,08E-06	5,59E-06	0,00E+00
	NHWD	kg	7,58E-02	8,33E-02	9,17E-02	1,01E-01	1,11E-01	0,00E+00
	RWD	kg	2,42E-06	2,67E-06	2,93E-06	3,22E-06	3,55E-06	0,00E+00
A4	HWD	kg	1,86E-06	2,04E-06	2,25E-06	2,47E-06	2,72E-06	0,00E+00
	NHWD	kg	3,15E-02	3,47E-02	3,82E-02	4,20E-02	4,62E-02	0,00E+00
	RWD	kg	6,15E-06	6,77E-06	7,45E-06	8,19E-06	9,01E-06	0,00E+00
C1	HWD	kg	0,00E+00	0,00E+00	0,00E+00	0,00E+00	0,00E+00	0,00E+00
	NHWD	kg	0,00E+00	0,00E+00	0,00E+00	0,00E+00	0,00E+00	0,00E+00
	RWD	kg	0,00E+00	0,00E+00	0,00E+00	0,00E+00	0,00E+00	0,00E+00
C2	HWD	kg	4,80E-07	5,28E-07	5,81E-07	6,39E-07	7,03E-07	0,00E+00
	NHWD	kg	9,25E-03	1,02E-02	1,12E-02	1,23E-02	1,35E-02	0,00E+00
	RWD	kg	1,19E-06	1,31E-06	1,44E-06	1,58E-06	1,74E-06	0,00E+00
C3	HWD	kg	0,00E+00	0,00E+00	0,00E+00	0,00E+00	0,00E+00	0,00E+00
	NHWD	kg	0,00E+00	0,00E+00	0,00E+00	0,00E+00	0,00E+00	0,00E+00
	RWD	kg	0,00E+00	0,00E+00	0,00E+00	0,00E+00	0,00E+00	0,00E+00
C4	HWD	kg	1,05E-07	1,15E-07	1,27E-07	1,39E-07	1,53E-07	0,00E+00
	NHWD	kg	9,42E-01	1,04E+00	1,14E+00	1,25E+00	1,38E+00	0,00E+00
	RWD	kg	4,53E-07	4,98E-07	5,48E-07	6,03E-07	6,63E-07	0,00E+00
D	HWD	kg	0,00E+00	0,00E+00	0,00E+00	0,00E+00	0,00E+00	0,00E+00
	NHWD	kg	2,96E-01	3,26E-01	3,58E-01	3,94E-01	4,33E-01	0,00E+00
	RWD	kg	0,00E+00	0,00E+00	0,00E+00	0,00E+00	0,00E+00	0,00E+00
TOTAL TOTALE	HWD	kg	1,33E-05	1,47E-05	1,61E-05	1,77E-05	1,95E-05	0,00E+00
	NHWD	kg	1,57E+00	1,73E+00	1,90E+00	2,09E+00	2,30E+00	0,00E+00
	RWD	kg	2,97E-05	3,26E-05	3,59E-05	3,95E-05	4,34E-05	0,00E+00

Environmental performance of Sherwood and Soundwood Lamella, thickness 14 mm – Impact

Performance ambientali delle lamelle Sherwood and Soundwood, spessore 14 mm - Impatti

Class legend – Material and weight class (kg)

Legenda Classi – Materiale e Classe di peso (Kg)

A:	<i>Sherwood and Soundwood lamella, fire resistant MDF</i>	<i>81,923kg/mq</i>
B:	<i>Sherwood and Soundwood lamella, fire resistant MDF</i>	<i>122,885 kg/mq</i>
C:	<i>Sherwood and Soundwood lamella, fire resistant MDF</i>	<i>163,846 kg/mq</i>

Legend – Potential environmental impact:

Legenda impatti:

PEI Potential environment impact

UM Unit of measure

GWP	Global warming potential, total
GWPf	Global warming potential, fossil
GWPb	Global warming potential, biogenic
GWPI	Global warming potential, land use
ODP	Ozone depletion potential
AP	Acidification potential of land and water
EPf	Eutrophication aquatic, freshwater
EPm	Eutrophication aquatic, marine
EPT	Eutrophication aquatic, terrestrial
POCP	Photochemical ozone creation potential
ADPe	Abiotic depletion potential, elements
ADPf	Abiotic depletion potential, fossil
WDP	Water depletion potential

Functional Unit: 1 m² of ceiling/wall covering

Unità funzionale: 1 m² di controsoffitto/rivestimento

PHASES FASI	PEI	UM	A	B	C
A1	<i>GWPf</i>	<i>kg CO2 eq</i>	3,01E+00	4,51E+00	6,01E+00
	<i>GWPb</i>	<i>kg CO2 eq</i>	5,96E-03	8,94E-03	1,19E-02
	<i>GWPI</i>	<i>kg CO2 eq</i>	3,74E-03	5,60E-03	7,47E-03
	<i>GWP</i>	<i>kg CO2 eq</i>	3,02E+00	4,53E+00	6,03E+00
	<i>AP</i>	<i>mol H+ eq</i>	2,10E-02	3,14E-02	4,19E-02
	<i>EPf</i>	<i>kg P eq</i>	1,17E-03	1,76E-03	2,35E-03
	<i>EPm</i>	<i>kg N eq</i>	5,18E-03	7,78E-03	1,04E-02
	<i>EPt</i>	<i>mol N eq</i>	6,29E-02	9,43E-02	1,26E-01
	<i>POCP</i>	<i>kg NMVOC</i>	1,85E-02	2,78E-02	3,71E-02
	<i>ADPe</i>	<i>kg Sb eq</i>	3,10E-05	4,65E-05	6,20E-05
	<i>ADPf</i>	<i>MJ</i>	5,06E+01	7,59E+01	1,01E+02
	<i>WDP</i>	<i>m3 eq</i>	3,01E+00	4,52E+00	6,03E+00
	<i>ODP</i>	<i>kg CFC-11 eq</i>	2,90E-07	4,35E-07	5,80E-07
	A2	<i>GWPf</i>	<i>kg CO2 eq</i>	6,96E-02	1,04E-01
<i>GWPb</i>		<i>kg CO2 eq</i>	2,05E-05	3,08E-05	4,10E-05
<i>GWPI</i>		<i>kg CO2 eq</i>	2,60E-05	3,90E-05	5,20E-05
<i>GWP</i>		<i>kg CO2 eq</i>	6,96E-02	1,04E-01	1,39E-01
<i>AP</i>		<i>mol H+ eq</i>	3,57E-04	5,36E-04	7,14E-04
<i>EPf</i>		<i>kg P eq</i>	4,41E-06	6,61E-06	8,82E-06
<i>EPm</i>		<i>kg N eq</i>	1,22E-04	1,84E-04	2,45E-04
<i>EPt</i>		<i>mol N eq</i>	1,34E-03	2,01E-03	2,68E-03
<i>POCP</i>		<i>kg NMVOC</i>	4,00E-04	6,01E-04	8,01E-04
<i>ADPe</i>		<i>kg Sb eq</i>	1,62E-07	2,44E-07	3,25E-07
<i>ADPf</i>		<i>MJ</i>	1,08E+00	1,62E+00	2,16E+00
<i>WDP</i>		<i>m3 depriv.</i>	3,82E-03	5,73E-03	7,64E-03
<i>ODP</i>		<i>kg CFC-11 eq</i>	1,34E-08	2,01E-08	2,68E-08
A3		<i>GWPf</i>	<i>kg CO2 eq</i>	1,69E+00	2,54E+00
	<i>GWPb</i>	<i>kg CO2 eq</i>	4,92E-03	7,38E-03	9,84E-03
	<i>GWPI</i>	<i>kg CO2 eq</i>	4,27E-04	6,41E-04	8,55E-04
	<i>GWP</i>	<i>kg CO2 eq</i>	1,70E+00	2,55E+00	3,39E+00
	<i>AP</i>	<i>mol H+ eq</i>	7,48E-03	1,12E-02	1,50E-02
	<i>EPf</i>	<i>kg P eq</i>	3,82E-04	5,73E-04	7,64E-04
	<i>EPm</i>	<i>kg N eq</i>	1,32E-03	1,98E-03	2,64E-03
	<i>EPt</i>	<i>mol N eq</i>	1,39E-02	2,09E-02	2,79E-02
	<i>POCP</i>	<i>kg NMVOC</i>	3,99E-03	5,99E-03	7,98E-03
	<i>ADPe</i>	<i>kg Sb eq</i>	2,19E-06	3,29E-06	4,39E-06
	<i>ADPf</i>	<i>MJ</i>	2,26E+01	3,40E+01	4,53E+01

PHASES FASI	PEI	UM	A	B	C
	WDP	m3 depriv.	4,69E-01	7,04E-01	9,38E-01
	ODP	kg CFC-11 eq	1,98E-07	2,98E-07	3,97E-07
A4	GWPf	kg CO2 eq	5,45E-01	8,18E-01	1,09E+00
	GWPb	kg CO2 eq	1,38E-04	2,06E-04	2,75E-04
	GWPI	kg CO2 eq	2,91E-04	4,37E-04	5,82E-04
	GWP	kg CO2 eq	5,46E-01	8,18E-01	1,09E+00
	AP	mol H+ eq	8,49E-03	1,27E-02	1,70E-02
	EPf	kg P eq	3,00E-05	4,50E-05	6,00E-05
	EPm	kg N eq	2,26E-03	3,39E-03	4,52E-03
	EPt	mol N eq	2,50E-02	3,75E-02	5,00E-02
	POCP	kg NMVOC	6,64E-03	9,96E-03	1,33E-02
	ADPe	kg Sb eq	1,48E-06	2,22E-06	2,96E-06
	ADPf	MJ	7,73E+00	1,16E+01	1,55E+01
	WDP	m3 depriv.	2,10E-02	3,15E-02	4,20E-02
	ODP	kg CFC-11 eq	9,48E-08	1,42E-07	1,90E-07
	C1	GWPf	kg CO2 eq	0,00E+00	0,00E+00
GWPb		kg CO2 eq	0,00E+00	0,00E+00	0,00E+00
GWPI		kg CO2 eq	0,00E+00	0,00E+00	0,00E+00
GWP		kg CO2 eq	0,00E+00	0,00E+00	0,00E+00
AP		mol H+ eq	0,00E+00	0,00E+00	0,00E+00
EPf		kg P eq	0,00E+00	0,00E+00	0,00E+00
EPm		kg N eq	0,00E+00	0,00E+00	0,00E+00
EPt		mol N eq	0,00E+00	0,00E+00	0,00E+00
POCP		kg NMVOC	0,00E+00	0,00E+00	0,00E+00
ADPe		kg Sb eq	0,00E+00	0,00E+00	0,00E+00
ADPf		MJ	0,00E+00	0,00E+00	0,00E+00
WDP		m3 depriv.	0,00E+00	0,00E+00	0,00E+00
ODP		kg CFC-11 eq	0,00E+00	0,00E+00	0,00E+00
C2		GWPf	kg CO2 eq	1,05E-01	1,57E-01
	GWPb	kg CO2 eq	2,90E-05	4,34E-05	5,79E-05
	GWPI	kg CO2 eq	4,52E-05	6,78E-05	9,04E-05
	GWP	kg CO2 eq	1,05E-01	1,57E-01	2,09E-01
	AP	mol H+ eq	5,37E-04	8,05E-04	1,07E-03
	EPf	kg P eq	7,95E-06	1,19E-05	1,59E-05
	EPm	kg N eq	1,82E-04	2,72E-04	3,63E-04
	EPt	mol N eq	1,98E-03	2,98E-03	3,97E-03
	POCP	kg NMVOC	5,65E-04	8,48E-04	1,13E-03

PHASES FASI	PEI	UM	A	B	C
	ADPe	kg Sb eq	3,63E-07	5,45E-07	7,27E-07
	ADPf	MJ	1,55E+00	2,33E+00	3,10E+00
	WDP	m3 depriv.	5,47E-03	8,21E-03	1,09E-02
	ODP	kg CFC-11 eq	1,82E-08	2,73E-08	3,64E-08
C3	GWPf	kg CO2 eq	0,00E+00	0,00E+00	0,00E+00
	GWPb	kg CO2 eq	0,00E+00	0,00E+00	0,00E+00
	GWPI	kg CO2 eq	0,00E+00	0,00E+00	0,00E+00
	GWP	kg CO2 eq	0,00E+00	0,00E+00	0,00E+00
	AP	mol H+ eq	0,00E+00	0,00E+00	0,00E+00
	EPf	kg P eq	0,00E+00	0,00E+00	0,00E+00
	EPm	kg N eq	0,00E+00	0,00E+00	0,00E+00
	EPT	mol N eq	0,00E+00	0,00E+00	0,00E+00
	POCP	kg NMVOC	0,00E+00	0,00E+00	0,00E+00
	ADPe	kg Sb eq	0,00E+00	0,00E+00	0,00E+00
	ADPf	MJ	0,00E+00	0,00E+00	0,00E+00
	WDP	m3 depriv.	0,00E+00	0,00E+00	0,00E+00
	ODP	kg CFC-11 eq	0,00E+00	0,00E+00	0,00E+00
	C4	GWPf	kg CO2 eq	5,14E-02	7,72E-02
GWPb		kg CO2 eq	1,33E-01	1,99E-01	2,65E-01
GWPI		kg CO2 eq	3,39E-05	5,09E-05	6,78E-05
GWP		kg CO2 eq	1,84E-01	2,76E-01	3,68E-01
AP		mol H+ eq	5,22E-04	7,83E-04	1,04E-03
EPf		kg P eq	1,87E-05	2,80E-05	3,73E-05
EPm		kg N eq	9,47E-04	1,42E-03	1,89E-03
EPT		mol N eq	2,38E-03	3,58E-03	4,77E-03
POCP		kg NMVOC	6,70E-04	1,00E-03	1,34E-03
ADPe		kg Sb eq	1,50E-07	2,25E-07	3,01E-07
ADPf		MJ	7,65E-01	1,15E+00	1,53E+00
WDP		m3 depriv.	-7,49E-04	-1,12E-03	-1,50E-03
ODP		kg CFC-11 eq	7,10E-09	1,06E-08	1,42E-08
D		GWPf	kg CO2 eq	0,00E+00	0,00E+00
	GWPb	kg CO2 eq	0,00E+00	0,00E+00	0,00E+00
	GWPI	kg CO2 eq	0,00E+00	0,00E+00	0,00E+00
	GWP	kg CO2 eq	0,00E+00	0,00E+00	0,00E+00
	AP	mol H+ eq	0,00E+00	0,00E+00	0,00E+00
	EPf	kg P eq	0,00E+00	0,00E+00	0,00E+00
	EPm	kg N eq	0,00E+00	0,00E+00	0,00E+00

PHASES FASI	PEI	UM	A	B	C
	<i>EPt</i>	<i>mol N eq</i>	0,00E+00	0,00E+00	0,00E+00
	<i>POCP</i>	<i>kg NMVOC</i>	0,00E+00	0,00E+00	0,00E+00
	<i>ADPe</i>	<i>kg Sb eq</i>	0,00E+00	0,00E+00	0,00E+00
	<i>ADPf</i>	<i>MJ</i>	0,00E+00	0,00E+00	0,00E+00
	<i>WDP</i>	<i>m3 depriv.</i>	0,00E+00	0,00E+00	0,00E+00
	<i>ODP</i>	<i>kg CFC-11 eq</i>	0,00E+00	0,00E+00	0,00E+00

Environmental performance of Sherwood and Soundwood Lamella, thickness 14 mm – Use of resources

Performance ambientali delle lamelle Sherwood and Soundwood, spessore 14 mm – Consumo di risorse

Class legend – Material and weight class (kg)

Legenda Classi – Materiale e Classe di peso (Kg)

A:	<i>Sherwood and Soundwood lamella, fire resistant MDF</i>	<i>81,923kg/mq</i>
B:	<i>Sherwood and Soundwood lamella, fire resistant MDF</i>	<i>122,885 kg/mq</i>
C:	<i>Sherwood and Soundwood lamella, fire resistant MDF</i>	<i>163,846 kg/mq</i>

Legend – Potential environmental impact:

Legenda impatti:

PEI Potential environment impact

UM Unit of measure

GWP	Global warming potential, total
GWPf	Global warming potential, fossil
GWPb	Global warming potential, biogenic
GWPI	Global warming potential, land use
ODP	Ozone depletion potential
AP	Acidification potential of land and water
EPf	Eutrophication aquatic, freshwater
EPm	Eutrophication aquatic, marine
EPt	Eutrophication aquatic, terrestrial
POCP	Photochemical ozone creation potential
ADPe	Abiotic depletion potential, elements
ADPf	Abiotic depletion potential, fossil
WDP	Water depletion potential

Functional Unit: 1 m² of ceiling/wall covering

Unità funzionale: 1 m² di controsoffitto/rivestimento

PHASES FASI	PEI	UM	A	B	C
A1	PERE	MJ	2,08E+00	3,13E+00	4,17E+00
	PERM	MJ	4,21E+01	6,32E+01	8,43E+01
	PERT	MJ	4,42E+01	6,63E+01	8,84E+01
	PENRE	MJ	5,06E+01	7,59E+01	1,01E+02
	PENRM	MJ	0,00E+00	0,00E+00	0,00E+00
	PENRT	MJ	5,06E+01	7,59E+01	1,01E+02
	SM	kg	0,00E+00	0,00E+00	0,00E+00
	RSF	MJ	0,00E+00	0,00E+00	0,00E+00
	NRSF	MJ	0,00E+00	0,00E+00	0,00E+00
	FW	m3	3,38E-01	5,07E-01	6,76E-01
A2	PERE	MJ	1,09E-02	1,63E-02	2,18E-02
	PERM	MJ	3,21E-03	4,81E-03	6,41E-03
	PERT	MJ	1,41E-02	2,11E-02	2,82E-02
	PENRE	MJ	1,08E+00	1,62E+00	2,16E+00
	PENRM	MJ	0,00E+00	0,00E+00	0,00E+00
	PENRT	MJ	1,08E+00	1,62E+00	2,16E+00
	SM	kg	0,00E+00	0,00E+00	0,00E+00
	RSF	MJ	0,00E+00	0,00E+00	0,00E+00
	NRSF	MJ	0,00E+00	0,00E+00	0,00E+00
	FW	m3	9,83E-04	1,47E-03	1,97E-03
A3	PERE	MJ	1,40E+00	2,10E+00	2,80E+00
	PERM	MJ	7,40E-01	1,11E+00	1,48E+00
	PERT	MJ	2,14E+00	3,21E+00	4,28E+00
	PENRE	MJ	2,26E+01	3,40E+01	4,53E+01
	PENRM	MJ	4,30E+00	6,45E+00	8,60E+00
	PENRT	MJ	2,69E+01	4,04E+01	5,39E+01
	SM	kg	0,00E+00	0,00E+00	0,00E+00
	RSF	MJ	0,00E+00	0,00E+00	0,00E+00
	NRSF	MJ	0,00E+00	0,00E+00	0,00E+00
	FW	m3	1,41E-01	2,12E-01	2,82E-01
A4	PERE	MJ	6,33E-02	9,50E-02	1,27E-01
	PERM	MJ	2,45E-02	3,68E-02	4,90E-02
	PERT	MJ	8,78E-02	1,32E-01	1,76E-01
	PENRE	MJ	7,73E+00	1,16E+01	1,55E+01
	PENRM	MJ	0,00E+00	0,00E+00	0,00E+00
	PENRT	MJ	7,73E+00	1,16E+01	1,55E+01
	SM	kg	0,00E+00	0,00E+00	0,00E+00

PHASES FASI	PEI	UM	A	B	C
	RSF	MJ	0,00E+00	0,00E+00	0,00E+00
	NRSF	MJ	0,00E+00	0,00E+00	0,00E+00
	FW	m3	5,60E-03	8,40E-03	1,12E-02
C1	PERE	MJ	0,00E+00	0,00E+00	0,00E+00
	PERM	MJ	0,00E+00	0,00E+00	0,00E+00
	PERT	MJ	0,00E+00	0,00E+00	0,00E+00
	PENRE	MJ	0,00E+00	0,00E+00	0,00E+00
	PENRM	MJ	0,00E+00	0,00E+00	0,00E+00
	PENRT	MJ	0,00E+00	0,00E+00	0,00E+00
	SM	kg	0,00E+00	0,00E+00	0,00E+00
	RSF	MJ	0,00E+00	0,00E+00	0,00E+00
	NRSF	MJ	0,00E+00	0,00E+00	0,00E+00
	FW	m3	0,00E+00	0,00E+00	0,00E+00
	C2	PERE	MJ	1,28E-02	1,92E-02
PERM		MJ	5,35E-03	8,02E-03	1,07E-02
PERT		MJ	1,82E-02	2,72E-02	3,63E-02
PENRE		MJ	1,55E+00	2,33E+00	3,10E+00
PENRM		MJ	0,00E+00	0,00E+00	0,00E+00
PENRT		MJ	1,55E+00	2,33E+00	3,10E+00
SM		kg	0,00E+00	0,00E+00	0,00E+00
RSF		MJ	0,00E+00	0,00E+00	0,00E+00
NRSF		MJ	0,00E+00	0,00E+00	0,00E+00
FW		m3	1,27E-03	1,90E-03	2,53E-03
C3		PERE	MJ	0,00E+00	0,00E+00
	PERM	MJ	0,00E+00	0,00E+00	0,00E+00
	PERT	MJ	0,00E+00	0,00E+00	0,00E+00
	PENRE	MJ	0,00E+00	0,00E+00	0,00E+00
	PENRM	MJ	0,00E+00	0,00E+00	0,00E+00
	PENRT	MJ	0,00E+00	0,00E+00	0,00E+00
	SM	kg	0,00E+00	0,00E+00	0,00E+00
	RSF	MJ	0,00E+00	0,00E+00	0,00E+00
	NRSF	MJ	0,00E+00	0,00E+00	0,00E+00
	FW	m3	0,00E+00	0,00E+00	0,00E+00
C4	PERE	MJ	1,16E-02	1,74E-02	2,32E-02
	PERM	MJ	4,45E-03	6,67E-03	8,90E-03
	PERT	MJ	1,61E-02	2,41E-02	3,21E-02
	PENRE	MJ	7,65E-01	1,15E+00	1,53E+00

PHASES FASI	PEI	UM	A	B	C
	<i>PENRM</i>	<i>MJ</i>	0,00E+00	0,00E+00	0,00E+00
	<i>PENRT</i>	<i>MJ</i>	7,65E-01	1,15E+00	1,53E+00
	<i>SM</i>	<i>kg</i>	0,00E+00	0,00E+00	0,00E+00
	<i>RSF</i>	<i>MJ</i>	0,00E+00	0,00E+00	0,00E+00
	<i>NRSF</i>	<i>MJ</i>	0,00E+00	0,00E+00	0,00E+00
	<i>FW</i>	<i>m3</i>	2,38E-03	3,56E-03	4,75E-03
D	<i>PERE</i>	<i>MJ</i>	0,00E+00	0,00E+00	0,00E+00
	<i>PERM</i>	<i>MJ</i>	0,00E+00	0,00E+00	0,00E+00
	<i>PERT</i>	<i>MJ</i>	0,00E+00	0,00E+00	0,00E+00
	<i>PENRE</i>	<i>MJ</i>	0,00E+00	0,00E+00	0,00E+00
	<i>PENRM</i>	<i>MJ</i>	0,00E+00	0,00E+00	0,00E+00
	<i>PENRT</i>	<i>MJ</i>	0,00E+00	0,00E+00	0,00E+00
	<i>SM</i>	<i>kg</i>	0,00E+00	0,00E+00	0,00E+00
	<i>RSF</i>	<i>MJ</i>	0,00E+00	0,00E+00	0,00E+00
	<i>NRSF</i>	<i>MJ</i>	0,00E+00	0,00E+00	0,00E+00
	<i>FW</i>	<i>m3</i>	0,00E+00	0,00E+00	0,00E+00

Environmental performance of Sherwood and Soundwood Lamella, thickness 14 mm – Waste production and output flows

Performance ambientali delle lamelle Sherwood and Soundwood, spessore 14 mm – Produzione di rifiuti e flussi in output

Class legend – Material and weight class (kg)

Legenda Classi – Materiale e Classe di peso (Kg)

- A:** Sherwood and Soundwood lamella, fire resistant MDF 81,923kg/mq
B: Sherwood and Soundwood lamella, fire resistant MDF 122,885 kg/mq
C: Sherwood and Soundwood lamella, fire resistant MDF 163,846 kg/mq

Legend – Potential environmental impact:

Legenda impatti:

PEI Potential environment impact

UM Unit of measure

- GWP** Global warming potential, total
GWPf Global warming potential, fossil
GWPb Global warming potential, biogenic
GWPI Global warming potential, land use
ODP Ozone depletion potential
AP Acidification potential of land and water
EPf Eutrophication aquatic, freshwater
EPm Eutrophication aquatic, marine
EPT Eutrophication aquatic, terrestrial
POCP Photochemical ozone creation potential
ADPe Abiotic depletion potential, elements
ADPf Abiotic depletion potential, fossil
WDP Water depletion potential

Functional Unit: 1 m² of ceiling/wall covering

Unità funzionale: 1 m² di controsoffitto/rivestimento

PHASES FASI	WASTE RIFIUTI	UM	A	B	C
A1	HWD	kg	6,75E-05	1,01E-04	1,35E-04
	NHWD	kg	5,18E-01	7,77E-01	1,04E+00
	RWD	kg	1,26E-04	1,88E-04	2,51E-04
A2	HWD	kg	2,67E-06	4,00E-06	5,34E-06
	NHWD	kg	1,03E-01	1,55E-01	2,07E-01
	RWD	kg	7,47E-06	1,12E-05	1,49E-05
A3	HWD	kg	3,30E-05	4,95E-05	6,59E-05
	NHWD	kg	6,55E-01	9,82E-01	1,31E+00
	RWD	kg	2,09E-05	3,14E-05	4,19E-05
A4	HWD	kg	1,61E-05	2,41E-05	3,21E-05
	NHWD	kg	2,73E-01	4,09E-01	5,45E-01
	RWD	kg	5,32E-05	7,98E-05	1,06E-04
C1	HWD	kg	0,00E+00	0,00E+00	0,00E+00
	NHWD	kg	0,00E+00	0,00E+00	0,00E+00
	RWD	kg	0,00E+00	0,00E+00	0,00E+00
C2	HWD	kg	4,15E-06	6,22E-06	8,30E-06
	NHWD	kg	7,99E-02	1,20E-01	1,60E-01
	RWD	kg	1,03E-05	1,54E-05	2,05E-05
C3	HWD	kg	0,00E+00	0,00E+00	0,00E+00
	NHWD	kg	0,00E+00	0,00E+00	0,00E+00
	RWD	kg	0,00E+00	0,00E+00	0,00E+00
C4	HWD	kg	1,42E-06	2,12E-06	2,83E-06
	NHWD	kg	6,19E+00	9,28E+00	1,24E+01
	RWD	kg	3,54E-06	5,30E-06	7,07E-06
D	HWD	kg	0,00E+00	0,00E+00	0,00E+00
	NHWD	kg	0,00E+00	0,00E+00	0,00E+00
	RWD	kg	0,00E+00	0,00E+00	0,00E+00
TOTAL TOTALE	HWD	kg	1,25E-04	1,87E-04	2,49E-04
	NHWD	kg	7,81E+00	1,17E+01	1,56E+01
	RWD	kg	2,21E-04	3,31E-04	4,42E-04

PHASES FASI	OUTPUT FLOWS FLUSSI IN OUTPUT	Unità	A	B	C
A1	CRU	kg	0,00E+00	0,00E+00	0,00E+00

PHASES FASI	OUTPUT FLOWS FLUSSI IN OUTPUT	Unità	A	B	C
	MFR	kg	0,00E+00	0,00E+00	0,00E+00
	MER	kg	0,00E+00	0,00E+00	0,00E+00
	EEE	MJ	0,00E+00	0,00E+00	0,00E+00
	EET	MJ	0,00E+00	0,00E+00	0,00E+00
A2	CRU	kg	0,00E+00	0,00E+00	0,00E+00
	MFR	kg	0,00E+00	0,00E+00	0,00E+00
	MER	kg	0,00E+00	0,00E+00	0,00E+00
	EEE	MJ	0,00E+00	0,00E+00	0,00E+00
A3	EET	MJ	0,00E+00	0,00E+00	0,00E+00
	CRU	kg	0,00E+00	0,00E+00	0,00E+00
	MFR	kg	0,00E+00	0,00E+00	0,00E+00
	MER	kg	0,00E+00	0,00E+00	0,00E+00
A4	EEE	MJ	0,00E+00	0,00E+00	0,00E+00
	EET	MJ	0,00E+00	0,00E+00	0,00E+00
	CRU	kg	0,00E+00	0,00E+00	0,00E+00
	MFR	kg	0,00E+00	0,00E+00	0,00E+00
C1	MER	kg	0,00E+00	0,00E+00	0,00E+00
	EEE	MJ	0,00E+00	0,00E+00	0,00E+00
	EET	MJ	0,00E+00	0,00E+00	0,00E+00
	CRU	kg	0,00E+00	0,00E+00	0,00E+00
C2	MFR	kg	0,00E+00	0,00E+00	0,00E+00
	MER	kg	0,00E+00	0,00E+00	0,00E+00
	EEE	MJ	0,00E+00	0,00E+00	0,00E+00
	EET	MJ	0,00E+00	0,00E+00	0,00E+00
C3	CRU	kg	0,00E+00	0,00E+00	0,00E+00
	MFR	kg	0,00E+00	0,00E+00	0,00E+00
	MER	kg	0,00E+00	0,00E+00	0,00E+00
	EEE	MJ	0,00E+00	0,00E+00	0,00E+00
C4	EET	MJ	0,00E+00	0,00E+00	0,00E+00
	CRU	kg	0,00E+00	0,00E+00	0,00E+00
	MFR	kg	0,00E+00	0,00E+00	0,00E+00
	MER	kg	0,00E+00	0,00E+00	0,00E+00

PHASES FASI	OUTPUT FLOWS FLUSSI IN OUTPUT	Unità	A	B	C
	<i>EEE</i>	<i>MJ</i>	0,00E+00	0,00E+00	0,00E+00
	<i>EET</i>	<i>MJ</i>	0,00E+00	0,00E+00	0,00E+00
D	<i>CRU</i>	<i>kg</i>	0,00E+00	0,00E+00	0,00E+00
	<i>MFR</i>	<i>kg</i>	0,00E+00	0,00E+00	0,00E+00
	<i>MER</i>	<i>kg</i>	0,00E+00	0,00E+00	0,00E+00
	<i>EEE</i>	<i>MJ</i>	0,00E+00	0,00E+00	0,00E+00
	<i>EET</i>	<i>MJ</i>	0,00E+00	0,00E+00	0,00E+00

Environmental performance of Sherwood and Soundwood Lamella, thickness 15 mm – Impact

Performance ambientali delle lamelle Sherwood and Soundwood, spessore 15 mm - Impatti

Class legend – Material and weight class (kg)

Legenda Classi – Materiale e Classe di peso (Kg)

A:	<i>Sherwood and Soundwood lamella, fire resistant MDF</i>	<i>81,857 kg/mq</i>
B:	<i>Sherwood and Soundwood lamella, fire resistant MDF</i>	<i>122,786kg/mq</i>
C:	<i>Sherwood and Soundwood lamella, fire resistant MDF</i>	<i>163,714 kg/mq</i>

Legend – Potential environmental impact:

Legenda impatti:

PEI Potential environment impact

UM Unit of measure

GWP	Global warming potential, total
GWPf	Global warming potential, fossil
GWPb	Global warming potential, biogenic
GWPI	Global warming potential, land use
ODP	Ozone depletion potential
AP	Acidification potential of land and water
EPf	Eutrophication aquatic, freshwater
EPm	Eutrophication aquatic, marine
EPT	Eutrophication aquatic, terrestrial
POCP	Photochemical ozone creation potential
ADPe	Abiotic depletion potential, elements
ADPf	Abiotic depletion potential, fossil
WDP	Water depletion potential

Functional Unit: 1 m² of ceiling/wall covering

Unità funzionale: 1 m² di controsoffitto/rivestimento

PHASES FASI	PEI	UM	A	B	C
A1	<i>GWPf</i>	<i>kg CO2 eq</i>	3,01E+00	4,51E+00	6,01E+00
	<i>GWPb</i>	<i>kg CO2 eq</i>	5,96E-03	8,93E-03	1,19E-02
	<i>GWPI</i>	<i>kg CO2 eq</i>	3,73E-03	5,60E-03	7,47E-03
	GWP	kg CO2 eq	3,02E+00	4,52E+00	6,03E+00
	<i>AP</i>	<i>mol H+ eq</i>	2,09E-02	3,14E-02	4,19E-02
	<i>EPf</i>	<i>kg P eq</i>	1,17E-03	1,76E-03	2,34E-03
	<i>EPm</i>	<i>kg N eq</i>	5,18E-03	7,77E-03	1,04E-02
	<i>EPt</i>	<i>mol N eq</i>	6,28E-02	9,43E-02	1,26E-01
	<i>POCP</i>	<i>kg NMVOC</i>	1,85E-02	2,78E-02	3,71E-02
	<i>ADPe</i>	<i>kg Sb eq</i>	3,10E-05	4,65E-05	6,19E-05
	<i>ADPf</i>	<i>MJ</i>	5,05E+01	7,58E+01	1,01E+02
	<i>WDP</i>	<i>m3 eq</i>	3,01E+00	4,52E+00	6,02E+00
	<i>ODP</i>	<i>kg CFC-11 eq</i>	2,90E-07	4,35E-07	5,80E-07
A2	<i>GWPf</i>	<i>kg CO2 eq</i>	1,65E-01	2,48E-01	3,30E-01
	<i>GWPb</i>	<i>kg CO2 eq</i>	4,87E-05	7,31E-05	9,74E-05
	<i>GWPI</i>	<i>kg CO2 eq</i>	6,17E-05	9,25E-05	1,23E-04
	GWP	kg CO2 eq	1,65E-01	2,48E-01	3,30E-01
	<i>AP</i>	<i>mol H+ eq</i>	8,48E-04	1,27E-03	1,70E-03
	<i>EPf</i>	<i>kg P eq</i>	1,05E-05	1,57E-05	2,09E-05
	<i>EPm</i>	<i>kg N eq</i>	2,91E-04	4,36E-04	5,82E-04
	<i>EPt</i>	<i>mol N eq</i>	3,18E-03	4,77E-03	6,36E-03
	<i>POCP</i>	<i>kg NMVOC</i>	9,50E-04	1,43E-03	1,90E-03
	<i>ADPe</i>	<i>kg Sb eq</i>	3,86E-07	5,78E-07	7,71E-07
	<i>ADPf</i>	<i>MJ</i>	2,57E+00	3,85E+00	5,14E+00
	<i>WDP</i>	<i>m3 depriv.</i>	9,07E-03	1,36E-02	1,81E-02
	<i>ODP</i>	<i>kg CFC-11 eq</i>	3,18E-08	4,77E-08	6,35E-08
A3	<i>GWPf</i>	<i>kg CO2 eq</i>	1,69E+00	2,54E+00	3,38E+00
	<i>GWPb</i>	<i>kg CO2 eq</i>	4,92E-03	7,38E-03	9,83E-03
	<i>GWPI</i>	<i>kg CO2 eq</i>	4,27E-04	6,40E-04	8,54E-04
	GWP	kg CO2 eq	1,70E+00	2,54E+00	3,39E+00
	<i>AP</i>	<i>mol H+ eq</i>	7,48E-03	1,12E-02	1,50E-02
	<i>EPf</i>	<i>kg P eq</i>	3,81E-04	5,72E-04	7,63E-04
	<i>EPm</i>	<i>kg N eq</i>	1,32E-03	1,98E-03	2,64E-03
	<i>EPt</i>	<i>mol N eq</i>	1,39E-02	2,09E-02	2,79E-02
	<i>POCP</i>	<i>kg NMVOC</i>	3,99E-03	5,98E-03	7,97E-03
	<i>ADPe</i>	<i>kg Sb eq</i>	2,19E-06	3,29E-06	4,38E-06
	<i>ADPf</i>	<i>MJ</i>	2,26E+01	3,39E+01	4,53E+01

PHASES FASI	PEI	UM	A	B	C	
	WDP	m3 depriv.	4,69E-01	7,03E-01	9,38E-01	
	ODP	kg CFC-11 eq	1,98E-07	2,97E-07	3,96E-07	
A4	GWPf	kg CO2 eq	5,45E-01	8,17E-01	1,09E+00	
	GWPb	kg CO2 eq	1,37E-04	2,06E-04	2,75E-04	
	GWPI	kg CO2 eq	2,91E-04	4,36E-04	5,82E-04	
	GWP	kg CO2 eq	5,45E-01	8,18E-01	1,09E+00	
	AP	mol H+ eq	8,49E-03	1,27E-02	1,70E-02	
	EPf	kg P eq	3,00E-05	4,50E-05	5,99E-05	
	EPm	kg N eq	2,26E-03	3,38E-03	4,51E-03	
	EPT	mol N eq	2,50E-02	3,74E-02	4,99E-02	
	POCP	kg NMVOC	6,63E-03	9,95E-03	1,33E-02	
	ADPe	kg Sb eq	1,48E-06	2,22E-06	2,96E-06	
	ADPf	MJ	7,72E+00	1,16E+01	1,54E+01	
	WDP	m3 depriv.	2,10E-02	3,14E-02	4,19E-02	
	ODP	kg CFC-11 eq	9,47E-08	1,42E-07	1,89E-07	
	C1	GWPf	kg CO2 eq	0,00E+00	0,00E+00	0,00E+00
		GWPb	kg CO2 eq	0,00E+00	0,00E+00	0,00E+00
GWPI		kg CO2 eq	0,00E+00	0,00E+00	0,00E+00	
GWP		kg CO2 eq	0,00E+00	0,00E+00	0,00E+00	
AP		mol H+ eq	0,00E+00	0,00E+00	0,00E+00	
EPf		kg P eq	0,00E+00	0,00E+00	0,00E+00	
EPm		kg N eq	0,00E+00	0,00E+00	0,00E+00	
EPT		mol N eq	0,00E+00	0,00E+00	0,00E+00	
POCP		kg NMVOC	0,00E+00	0,00E+00	0,00E+00	
ADPe		kg Sb eq	0,00E+00	0,00E+00	0,00E+00	
ADPf		MJ	0,00E+00	0,00E+00	0,00E+00	
WDP		m3 depriv.	0,00E+00	0,00E+00	0,00E+00	
ODP		kg CFC-11 eq	0,00E+00	0,00E+00	0,00E+00	
C2		GWPf	kg CO2 eq	1,04E-01	1,57E-01	2,09E-01
		GWPb	kg CO2 eq	2,89E-05	4,34E-05	5,79E-05
	GWPI	kg CO2 eq	4,52E-05	6,78E-05	9,04E-05	
	GWP	kg CO2 eq	1,05E-01	1,57E-01	2,09E-01	
	AP	mol H+ eq	5,36E-04	8,04E-04	1,07E-03	
	EPf	kg P eq	7,95E-06	1,19E-05	1,59E-05	
	EPm	kg N eq	1,81E-04	2,72E-04	3,63E-04	
	EPT	mol N eq	1,98E-03	2,97E-03	3,97E-03	
	POCP	kg NMVOC	5,65E-04	8,47E-04	1,13E-03	

PHASES FASI	PEI	UM	A	B	C
	ADPe	kg Sb eq	3,63E-07	5,44E-07	7,26E-07
	ADPf	MJ	1,55E+00	2,32E+00	3,10E+00
	WDP	m3 depriv.	5,47E-03	8,20E-03	1,09E-02
	ODP	kg CFC-11 eq	1,82E-08	2,73E-08	3,64E-08
C3	GWPf	kg CO2 eq	0,00E+00	0,00E+00	0,00E+00
	GWPb	kg CO2 eq	0,00E+00	0,00E+00	0,00E+00
	GWPI	kg CO2 eq	0,00E+00	0,00E+00	0,00E+00
	GWP	kg CO2 eq	0,00E+00	0,00E+00	0,00E+00
	AP	mol H+ eq	0,00E+00	0,00E+00	0,00E+00
	EPf	kg P eq	0,00E+00	0,00E+00	0,00E+00
	EPm	kg N eq	0,00E+00	0,00E+00	0,00E+00
	EPt	mol N eq	0,00E+00	0,00E+00	0,00E+00
	POCP	kg NMVOC	0,00E+00	0,00E+00	0,00E+00
	ADPe	kg Sb eq	0,00E+00	0,00E+00	0,00E+00
	ADPf	MJ	0,00E+00	0,00E+00	0,00E+00
	WDP	m3 depriv.	0,00E+00	0,00E+00	0,00E+00
	ODP	kg CFC-11 eq	0,00E+00	0,00E+00	0,00E+00
	C4	GWPf	kg CO2 eq	5,14E-02	7,71E-02
GWPb		kg CO2 eq	1,33E-01	1,99E-01	2,65E-01
GWPI		kg CO2 eq	3,39E-05	5,08E-05	6,78E-05
GWP		kg CO2 eq	1,84E-01	2,76E-01	3,68E-01
AP		mol H+ eq	5,22E-04	7,82E-04	1,04E-03
EPf		kg P eq	1,86E-05	2,80E-05	3,73E-05
EPm		kg N eq	9,47E-04	1,42E-03	1,89E-03
EPt		mol N eq	2,38E-03	3,57E-03	4,76E-03
POCP		kg NMVOC	6,69E-04	1,00E-03	1,34E-03
ADPe		kg Sb eq	1,50E-07	2,25E-07	3,00E-07
ADPf		MJ	7,65E-01	1,15E+00	1,53E+00
WDP		m3 depriv.	-7,49E-04	-1,12E-03	-1,50E-03
ODP		kg CFC-11 eq	7,09E-09	1,06E-08	1,42E-08
D		GWPf	kg CO2 eq	0,00E+00	0,00E+00
	GWPb	kg CO2 eq	0,00E+00	0,00E+00	0,00E+00
	GWPI	kg CO2 eq	0,00E+00	0,00E+00	0,00E+00
	GWP	kg CO2 eq	0,00E+00	0,00E+00	0,00E+00
	AP	mol H+ eq	0,00E+00	0,00E+00	0,00E+00
	EPf	kg P eq	0,00E+00	0,00E+00	0,00E+00
	EPm	kg N eq	0,00E+00	0,00E+00	0,00E+00

PHASES FASI	PEI	UM	A	B	C
	<i>EPt</i>	<i>mol N eq</i>	0,00E+00	0,00E+00	0,00E+00
	<i>POCP</i>	<i>kg NMVOC</i>	0,00E+00	0,00E+00	0,00E+00
	<i>ADPe</i>	<i>kg Sb eq</i>	0,00E+00	0,00E+00	0,00E+00
	<i>ADPf</i>	<i>MJ</i>	0,00E+00	0,00E+00	0,00E+00
	<i>WDP</i>	<i>m3 depriv.</i>	0,00E+00	0,00E+00	0,00E+00
	<i>ODP</i>	<i>kg CFC-11 eq</i>	0,00E+00	0,00E+00	0,00E+00

Environmental performance of Sherwood and Soundwood Lamella, thickness 15 mm – Use of resources

Performance ambientali delle lamelle Sherwood and Soundwood, spessore 15 mm – Consumo di risorse

Class legend – Material and weight class (kg)

Legenda Classi – Materiale e Classe di peso (Kg)

A:	<i>Sherwood and Soundwood lamella, fire resistant MDF</i>	<i>81,857 kg/mq</i>
B:	<i>Sherwood and Soundwood lamella, fire resistant MDF</i>	<i>122,786kg/mq</i>
C:	<i>Sherwood and Soundwood lamella, fire resistant MDF</i>	<i>163,714 kg/mq</i>

Legend – Potential environmental impact:

Legenda impatti:

PEI Potential environment impact

UM Unit of measure

GWP	Global warming potential, total
GWPf	Global warming potential, fossil
GWPb	Global warming potential, biogenic
GWPI	Global warming potential, land use
ODP	Ozone depletion potential
AP	Acidification potential of land and water
EPf	Eutrophication aquatic, freshwater
EPm	Eutrophication aquatic, marine
EPT	Eutrophication aquatic, terrestrial
POCP	Photochemical ozone creation potential
ADPe	Abiotic depletion potential, elements
ADPf	Abiotic depletion potential, fossil
WDP	Water depletion potential

Functional Unit: 1 m² of ceiling/wall covering

Unità funzionale: 1 m² di controsoffitto/rivestimento

PHASES FASI	PEI	UM	A	B	C
A1	PERE	MJ	2,08E+00	3,13E+00	4,17E+00
	PERM	MJ	4,21E+01	6,32E+01	8,42E+01
	PERT	MJ	4,42E+01	6,63E+01	8,84E+01
	PENRE	MJ	5,05E+01	7,58E+01	1,01E+02
	PENRM	MJ	0,00E+00	0,00E+00	0,00E+00
	PENRT	MJ	5,05E+01	7,58E+01	1,01E+02
	SM	kg	0,00E+00	0,00E+00	0,00E+00
	RSF	MJ	0,00E+00	0,00E+00	0,00E+00
	NRSF	MJ	0,00E+00	0,00E+00	0,00E+00
	FW	m3	3,38E-01	5,07E-01	6,75E-01
A2	PERE	MJ	2,59E-02	3,88E-02	5,17E-02
	PERM	MJ	7,61E-03	1,14E-02	1,52E-02
	PERT	MJ	3,35E-02	5,02E-02	6,69E-02
	PENRE	MJ	2,57E+00	3,85E+00	5,14E+00
	PENRM	MJ	0,00E+00	0,00E+00	0,00E+00
	PENRT	MJ	2,57E+00	3,85E+00	5,14E+00
	SM	kg	0,00E+00	0,00E+00	0,00E+00
	RSF	MJ	0,00E+00	0,00E+00	0,00E+00
	NRSF	MJ	0,00E+00	0,00E+00	0,00E+00
	FW	m3	2,33E-03	3,50E-03	4,67E-03
A3	PERE	MJ	1,40E+00	2,10E+00	2,80E+00
	PERM	MJ	7,39E-01	1,11E+00	1,48E+00
	PERT	MJ	2,14E+00	3,21E+00	4,28E+00
	PENRE	MJ	2,26E+01	3,39E+01	4,53E+01
	PENRM	MJ	4,30E+00	6,44E+00	8,59E+00
	PENRT	MJ	2,69E+01	4,04E+01	5,38E+01
	SM	kg	0,00E+00	0,00E+00	0,00E+00
	RSF	MJ	0,00E+00	0,00E+00	0,00E+00
	NRSF	MJ	0,00E+00	0,00E+00	0,00E+00
	FW	m3	1,41E-01	2,12E-01	2,82E-01
A4	PERE	MJ	6,33E-02	9,49E-02	1,27E-01
	PERM	MJ	2,45E-02	3,67E-02	4,90E-02
	PERT	MJ	8,77E-02	1,32E-01	1,75E-01
	PENRE	MJ	7,72E+00	1,16E+01	1,54E+01
	PENRM	MJ	0,00E+00	0,00E+00	0,00E+00
	PENRT	MJ	7,72E+00	1,16E+01	1,54E+01
	SM	kg	0,00E+00	0,00E+00	0,00E+00

PHASES FASI	PEI	UM	A	B	C	
	<i>RSF</i>	<i>MJ</i>	0,00E+00	0,00E+00	0,00E+00	
	<i>NRSF</i>	<i>MJ</i>	0,00E+00	0,00E+00	0,00E+00	
	<i>FW</i>	<i>m3</i>	5,60E-03	8,39E-03	1,12E-02	
C1	<i>PERE</i>	<i>MJ</i>	0,00E+00	0,00E+00	0,00E+00	
	<i>PERM</i>	<i>MJ</i>	0,00E+00	0,00E+00	0,00E+00	
	<i>PERT</i>	<i>MJ</i>	0,00E+00	0,00E+00	0,00E+00	
	<i>PENRE</i>	<i>MJ</i>	0,00E+00	0,00E+00	0,00E+00	
	<i>PENRM</i>	<i>MJ</i>	0,00E+00	0,00E+00	0,00E+00	
	<i>PENRT</i>	<i>MJ</i>	0,00E+00	0,00E+00	0,00E+00	
	<i>SM</i>	<i>kg</i>	0,00E+00	0,00E+00	0,00E+00	
	<i>RSF</i>	<i>MJ</i>	0,00E+00	0,00E+00	0,00E+00	
	<i>NRSF</i>	<i>MJ</i>	0,00E+00	0,00E+00	0,00E+00	
	<i>FW</i>	<i>m3</i>	0,00E+00	0,00E+00	0,00E+00	
	C2	<i>PERE</i>	<i>MJ</i>	1,28E-02	1,92E-02	2,56E-02
		<i>PERM</i>	<i>MJ</i>	5,34E-03	8,01E-03	1,07E-02
<i>PERT</i>		<i>MJ</i>	1,81E-02	2,72E-02	3,63E-02	
<i>PENRE</i>		<i>MJ</i>	1,55E+00	2,32E+00	3,10E+00	
<i>PENRM</i>		<i>MJ</i>	0,00E+00	0,00E+00	0,00E+00	
<i>PENRT</i>		<i>MJ</i>	1,55E+00	2,32E+00	3,10E+00	
<i>SM</i>		<i>kg</i>	0,00E+00	0,00E+00	0,00E+00	
<i>RSF</i>		<i>MJ</i>	0,00E+00	0,00E+00	0,00E+00	
<i>NRSF</i>		<i>MJ</i>	0,00E+00	0,00E+00	0,00E+00	
<i>FW</i>		<i>m3</i>	1,27E-03	1,90E-03	2,53E-03	
C3		<i>PERE</i>	<i>MJ</i>	0,00E+00	0,00E+00	0,00E+00
		<i>PERM</i>	<i>MJ</i>	0,00E+00	0,00E+00	0,00E+00
	<i>PERT</i>	<i>MJ</i>	0,00E+00	0,00E+00	0,00E+00	
	<i>PENRE</i>	<i>MJ</i>	0,00E+00	0,00E+00	0,00E+00	
	<i>PENRM</i>	<i>MJ</i>	0,00E+00	0,00E+00	0,00E+00	
	<i>PENRT</i>	<i>MJ</i>	0,00E+00	0,00E+00	0,00E+00	
	<i>SM</i>	<i>kg</i>	0,00E+00	0,00E+00	0,00E+00	
	<i>RSF</i>	<i>MJ</i>	0,00E+00	0,00E+00	0,00E+00	
	<i>NRSF</i>	<i>MJ</i>	0,00E+00	0,00E+00	0,00E+00	
	<i>FW</i>	<i>m3</i>	0,00E+00	0,00E+00	0,00E+00	
C4	<i>PERE</i>	<i>MJ</i>	1,16E-02	1,74E-02	2,32E-02	
	<i>PERM</i>	<i>MJ</i>	4,45E-03	6,67E-03	8,89E-03	
	<i>PERT</i>	<i>MJ</i>	1,60E-02	2,41E-02	3,21E-02	
	<i>PENRE</i>	<i>MJ</i>	7,65E-01	1,15E+00	1,53E+00	

PHASES FASI	PEI	UM	A	B	C
	<i>PENRM</i>	<i>MJ</i>	0,00E+00	0,00E+00	0,00E+00
	<i>PENRT</i>	<i>MJ</i>	7,65E-01	1,15E+00	1,53E+00
	<i>SM</i>	<i>kg</i>	0,00E+00	0,00E+00	0,00E+00
	<i>RSF</i>	<i>MJ</i>	0,00E+00	0,00E+00	0,00E+00
	<i>NRSF</i>	<i>MJ</i>	0,00E+00	0,00E+00	0,00E+00
	<i>FW</i>	<i>m3</i>	2,37E-03	3,56E-03	4,75E-03
D	<i>PERE</i>	<i>MJ</i>	0,00E+00	0,00E+00	0,00E+00
	<i>PERM</i>	<i>MJ</i>	0,00E+00	0,00E+00	0,00E+00
	<i>PERT</i>	<i>MJ</i>	0,00E+00	0,00E+00	0,00E+00
	<i>PENRE</i>	<i>MJ</i>	0,00E+00	0,00E+00	0,00E+00
	<i>PENRM</i>	<i>MJ</i>	0,00E+00	0,00E+00	0,00E+00
	<i>PENRT</i>	<i>MJ</i>	0,00E+00	0,00E+00	0,00E+00
	<i>SM</i>	<i>kg</i>	0,00E+00	0,00E+00	0,00E+00
	<i>RSF</i>	<i>MJ</i>	0,00E+00	0,00E+00	0,00E+00
	<i>NRSF</i>	<i>MJ</i>	0,00E+00	0,00E+00	0,00E+00
	<i>FW</i>	<i>m3</i>	0,00E+00	0,00E+00	0,00E+00

Environmental performance of Sherwood and Soundwood Lamella, thickness 15 mm - Waste production and output flows

Performance ambientali delle lamelle Sherwood and Soundwood, spessore 15 mm - Produzione di rifiuti e flussi in output

Class legend – Material and weight class (kg)

Legenda Classi – Materiale e Classe di peso (Kg)

A:	<i>Sherwood and Soundwood lamella, fire resistant MDF</i>	<i>81,857 kg/mq</i>
B:	<i>Sherwood and Soundwood lamella, fire resistant MDF</i>	<i>122,786kg/mq</i>
C:	<i>Sherwood and Soundwood lamella, fire resistant MDF</i>	<i>163,714 kg/mq</i>

Legend – Potential environmental impact:

Legenda impatti:

PEI Potential environment impact

UM Unit of measure

GWP	Global warming potential, total
GWPf	Global warming potential, fossil
GWPb	Global warming potential, biogenic
GWPI	Global warming potential, land use
ODP	Ozone depletion potential
AP	Acidification potential of land and water
EPf	Eutrophication aquatic, freshwater
EPm	Eutrophication aquatic, marine
EPT	Eutrophication aquatic, terrestrial
POCP	Photochemical ozone creation potential
ADPe	Abiotic depletion potential, elements
ADPf	Abiotic depletion potential, fossil
WDP	Water depletion potential

Functional Unit: 1 m² of ceiling/wall covering

Unità funzionale: 1 m² di controsoffitto/rivestimento

PHASES FASI	WASTE RIFIUTI	UM	A	B	C
A1	HWD	kg	6,74E-05	1,01E-04	1,35E-04
	NHWD	kg	5,17E-01	7,76E-01	1,03E+00
	RWD	kg	1,26E-04	1,88E-04	2,51E-04
A2	HWD	kg	6,34E-06	9,50E-06	1,27E-05
	NHWD	kg	2,45E-01	3,68E-01	4,91E-01
	RWD	kg	1,77E-05	2,66E-05	3,55E-05
A3	HWD	kg	3,29E-05	4,94E-05	6,59E-05
	NHWD	kg	6,54E-01	9,81E-01	1,31E+00
	RWD	kg	2,09E-05	3,14E-05	4,18E-05
A4	HWD	kg	1,60E-05	2,41E-05	3,21E-05
	NHWD	kg	2,72E-01	4,09E-01	5,45E-01
	RWD	kg	5,31E-05	7,97E-05	1,06E-04
C1	HWD	kg	0,00E+00	0,00E+00	0,00E+00
	NHWD	kg	0,00E+00	0,00E+00	0,00E+00
	RWD	kg	0,00E+00	0,00E+00	0,00E+00
C2	HWD	kg	4,15E-06	6,22E-06	8,29E-06
	NHWD	kg	7,99E-02	1,20E-01	1,60E-01
	RWD	kg	1,03E-05	1,54E-05	2,05E-05
C3	HWD	kg	0,00E+00	0,00E+00	0,00E+00
	NHWD	kg	0,00E+00	0,00E+00	0,00E+00
	RWD	kg	0,00E+00	0,00E+00	0,00E+00
C4	HWD	kg	1,41E-06	2,12E-06	2,83E-06
	NHWD	kg	6,18E+00	9,27E+00	1,24E+01
	RWD	kg	3,53E-06	5,30E-06	7,07E-06
D	HWD	kg	0,00E+00	0,00E+00	0,00E+00
	NHWD	kg	0,00E+00	0,00E+00	0,00E+00
	RWD	kg	0,00E+00	0,00E+00	0,00E+00
TOTAL TOTALE	HWD	kg	1,28E-04	1,92E-04	2,57E-04
	NHWD	kg	7,95E+00	1,19E+01	1,59E+01
	RWD	kg	2,31E-04	3,47E-04	4,62E-04

PHASES FASI	OUTPUT FLOWS FLUSSI IN OUTPUT	Unità	A	B	C
A1	CRU	kg	0,00E+00	0,00E+00	0,00E+00

PHASES FASI	OUTPUT FLOWS FLUSSI IN OUTPUT	Unità	A	B	C
	MFR	kg	0,00E+00	0,00E+00	0,00E+00
	MER	kg	0,00E+00	0,00E+00	0,00E+00
	EEE	MJ	0,00E+00	0,00E+00	0,00E+00
	EET	MJ	0,00E+00	0,00E+00	0,00E+00
A2	CRU	kg	0,00E+00	0,00E+00	0,00E+00
	MFR	kg	0,00E+00	0,00E+00	0,00E+00
	MER	kg	0,00E+00	0,00E+00	0,00E+00
	EEE	MJ	0,00E+00	0,00E+00	0,00E+00
A3	EET	MJ	0,00E+00	0,00E+00	0,00E+00
	CRU	kg	0,00E+00	0,00E+00	0,00E+00
	MFR	kg	0,00E+00	0,00E+00	0,00E+00
	MER	kg	0,00E+00	0,00E+00	0,00E+00
A4	EEE	MJ	0,00E+00	0,00E+00	0,00E+00
	EET	MJ	0,00E+00	0,00E+00	0,00E+00
	CRU	kg	0,00E+00	0,00E+00	0,00E+00
	MFR	kg	0,00E+00	0,00E+00	0,00E+00
C1	MER	kg	0,00E+00	0,00E+00	0,00E+00
	EEE	MJ	0,00E+00	0,00E+00	0,00E+00
	EET	MJ	0,00E+00	0,00E+00	0,00E+00
	CRU	kg	0,00E+00	0,00E+00	0,00E+00
C2	MFR	kg	0,00E+00	0,00E+00	0,00E+00
	MER	kg	0,00E+00	0,00E+00	0,00E+00
	EEE	MJ	0,00E+00	0,00E+00	0,00E+00
	EET	MJ	0,00E+00	0,00E+00	0,00E+00
C3	CRU	kg	0,00E+00	0,00E+00	0,00E+00
	MFR	kg	0,00E+00	0,00E+00	0,00E+00
	MER	kg	0,00E+00	0,00E+00	0,00E+00
	EEE	MJ	0,00E+00	0,00E+00	0,00E+00
C4	EET	MJ	0,00E+00	0,00E+00	0,00E+00
	CRU	kg	0,00E+00	0,00E+00	0,00E+00
	MFR	kg	0,00E+00	0,00E+00	0,00E+00
	MER	kg	0,00E+00	0,00E+00	0,00E+00

PHASES FASI	OUTPUT FLOWS FLUSSI IN OUTPUT	Unità	A	B	C
	<i>EEE</i>	<i>MJ</i>	0,00E+00	0,00E+00	0,00E+00
	<i>EET</i>	<i>MJ</i>	0,00E+00	0,00E+00	0,00E+00
D	<i>CRU</i>	<i>kg</i>	0,00E+00	0,00E+00	0,00E+00
	<i>MFR</i>	<i>kg</i>	-1,04E+01	-1,56E+01	-2,08E+01
	<i>MER</i>	<i>kg</i>	0,00E+00	0,00E+00	0,00E+00
	<i>EEE</i>	<i>MJ</i>	0,00E+00	0,00E+00	0,00E+00
	<i>EET</i>	<i>MJ</i>	0,00E+00	0,00E+00	0,00E+00

Environmental performance of Solid Wood Lamella - Impact

Performance ambientali delle lamelle in legno massello - Impatti

Class legend – Material and weight class (kg)

Legenda Classi – Materiale e Classe di peso (Kg)

A:	<i>Solid Wood lamella, solid fir wood</i>	<i>24 kg/mq</i>
B:	<i>Solid Wood lamella, solid fir wood</i>	<i>30 kg/mq</i>
C:	<i>Solid Wood lamella, solid fir wood</i>	<i>36 kg/mq</i>

Legend – Potential environmental impact:

Legenda impatti:

PEI Potential environment impact

UM Unit of measure

GWP	Global warming potential, total
GWPf	Global warming potential, fossil
GWPb	Global warming potential, biogenic
GWPI	Global warming potential, land use
ODP	Ozone depletion potential
AP	Acidification potential of land and water
EPf	Eutrophication aquatic, freshwater
EPm	Eutrophication aquatic, marine
EPT	Eutrophication aquatic, terrestrial
POCP	Photochemical ozone creation potential
ADPe	Abiotic depletion potential, elements
ADPf	Abiotic depletion potential, fossil
WDP	Water depletion potential

Functional Unit: 1 m² of ceiling/wall covering

Unità funzionale: 1 m² di controsoffitto/rivestimento

PHASES FASI	PEI	UM	A	B	C
A1	<i>GWPf</i>	<i>kg CO2 eq</i>	4,92E-02	6,15E-02	7,38E-02
	<i>GWPb</i>	<i>kg CO2 eq</i>	3,07E-04	3,84E-04	4,61E-04
	<i>GWPI</i>	<i>kg CO2 eq</i>	2,23E-03	2,79E-03	3,35E-03
	GWP	kg CO2 eq	5,17E-02	6,47E-02	7,76E-02
	<i>AP</i>	<i>mol H+ eq</i>	2,84E-04	3,55E-04	4,27E-04
	<i>EPf</i>	<i>kg P eq</i>	1,97E-05	2,47E-05	2,96E-05
	<i>EPm</i>	<i>kg N eq</i>	1,13E-04	1,42E-04	1,70E-04
	<i>EPt</i>	<i>mol N eq</i>	1,12E-03	1,41E-03	1,69E-03
	<i>POCP</i>	<i>kg NMVOC</i>	8,98E-04	1,12E-03	1,35E-03
	<i>ADPe</i>	<i>kg Sb eq</i>	1,30E-07	1,62E-07	1,95E-07
	<i>ADPf</i>	<i>MJ</i>	7,16E-01	8,95E-01	1,07E+00
	<i>WDP</i>	<i>m3 eq</i>	1,15E-02	1,44E-02	1,73E-02
	<i>ODP</i>	<i>kg CFC-11 eq</i>	8,90E-09	1,11E-08	1,33E-08
A2	<i>GWPf</i>	<i>kg CO2 eq</i>	2,03E-02	2,54E-02	3,05E-02
	<i>GWPb</i>	<i>kg CO2 eq</i>	6,00E-06	7,50E-06	9,00E-06
	<i>GWPI</i>	<i>kg CO2 eq</i>	7,59E-06	9,49E-06	1,14E-05
	GWP	kg CO2 eq	2,03E-02	2,54E-02	3,05E-02
	<i>AP</i>	<i>mol H+ eq</i>	1,04E-04	1,30E-04	1,57E-04
	<i>EPf</i>	<i>kg P eq</i>	1,29E-06	1,61E-06	1,93E-06
	<i>EPm</i>	<i>kg N eq</i>	3,58E-05	4,48E-05	5,37E-05
	<i>EPt</i>	<i>mol N eq</i>	3,92E-04	4,90E-04	5,88E-04
	<i>POCP</i>	<i>kg NMVOC</i>	1,17E-04	1,46E-04	1,76E-04
	<i>ADPe</i>	<i>kg Sb eq</i>	4,75E-08	5,94E-08	7,12E-08
	<i>ADPf</i>	<i>MJ</i>	3,16E-01	3,95E-01	4,75E-01
	<i>WDP</i>	<i>m3 depriv.</i>	1,12E-03	1,40E-03	1,67E-03
	<i>ODP</i>	<i>kg CFC-11 eq</i>	3,91E-09	4,89E-09	5,87E-09
A3	<i>GWPf</i>	<i>kg CO2 eq</i>	5,00E-01	6,25E-01	7,50E-01
	<i>GWPb</i>	<i>kg CO2 eq</i>	1,59E-03	1,99E-03	2,39E-03
	<i>GWPI</i>	<i>kg CO2 eq</i>	1,54E-04	1,92E-04	2,31E-04
	GWP	kg CO2 eq	5,02E-01	6,27E-01	7,53E-01
	<i>AP</i>	<i>mol H+ eq</i>	2,21E-03	2,76E-03	3,31E-03
	<i>EPf</i>	<i>kg P eq</i>	1,13E-04	1,42E-04	1,70E-04
	<i>EPm</i>	<i>kg N eq</i>	3,91E-04	4,89E-04	5,87E-04
	<i>EPt</i>	<i>mol N eq</i>	4,12E-03	5,15E-03	6,18E-03
	<i>POCP</i>	<i>kg NMVOC</i>	1,18E-03	1,48E-03	1,77E-03
	<i>ADPe</i>	<i>kg Sb eq</i>	6,62E-07	8,28E-07	9,94E-07
	<i>ADPf</i>	<i>MJ</i>	6,70E+00	8,38E+00	1,01E+01

PHASES FASI	PEI	UM	A	B	C	
	WDP	m3 depriv.	1,39E-01	1,74E-01	2,08E-01	
	ODP	kg CFC-11 eq	5,84E-08	7,31E-08	8,77E-08	
A4	GWPf	kg CO2 eq	1,60E-01	2,00E-01	2,40E-01	
	GWPb	kg CO2 eq	4,03E-05	5,04E-05	6,05E-05	
	GWPI	kg CO2 eq	8,53E-05	1,07E-04	1,28E-04	
	GWP	kg CO2 eq	1,60E-01	2,00E-01	2,40E-01	
	AP	mol H+ eq	2,49E-03	3,11E-03	3,73E-03	
	EPf	kg P eq	8,79E-06	1,10E-05	1,32E-05	
	EPm	kg N eq	6,61E-04	8,27E-04	9,92E-04	
	EPT	mol N eq	7,32E-03	9,15E-03	1,10E-02	
	POCP	kg NMVOC	1,94E-03	2,43E-03	2,92E-03	
	ADPe	kg Sb eq	4,33E-07	5,42E-07	6,50E-07	
	ADPf	MJ	2,26E+00	2,83E+00	3,40E+00	
	WDP	m3 depriv.	6,15E-03	7,68E-03	9,22E-03	
	ODP	kg CFC-11 eq	2,78E-08	3,47E-08	4,16E-08	
	C1	GWPf	kg CO2 eq	0,00E+00	0,00E+00	0,00E+00
		GWPb	kg CO2 eq	0,00E+00	0,00E+00	0,00E+00
GWPI		kg CO2 eq	0,00E+00	0,00E+00	0,00E+00	
GWP		kg CO2 eq	0,00E+00	0,00E+00	0,00E+00	
AP		mol H+ eq	0,00E+00	0,00E+00	0,00E+00	
EPf		kg P eq	0,00E+00	0,00E+00	0,00E+00	
EPm		kg N eq	0,00E+00	0,00E+00	0,00E+00	
EPT		mol N eq	0,00E+00	0,00E+00	0,00E+00	
POCP		kg NMVOC	0,00E+00	0,00E+00	0,00E+00	
ADPe		kg Sb eq	0,00E+00	0,00E+00	0,00E+00	
ADPf		MJ	0,00E+00	0,00E+00	0,00E+00	
WDP		m3 depriv.	0,00E+00	0,00E+00	0,00E+00	
ODP		kg CFC-11 eq	0,00E+00	0,00E+00	0,00E+00	
C2		GWPf	kg CO2 eq	3,06E-02	3,83E-02	4,60E-02
		GWPb	kg CO2 eq	8,49E-06	1,06E-05	1,27E-05
	GWPI	kg CO2 eq	1,32E-05	1,66E-05	1,99E-05	
	GWP	kg CO2 eq	3,07E-02	3,83E-02	4,60E-02	
	AP	mol H+ eq	1,57E-04	1,97E-04	2,36E-04	
	EPf	kg P eq	2,33E-06	2,91E-06	3,49E-06	
	EPm	kg N eq	5,32E-05	6,65E-05	7,98E-05	
	EPT	mol N eq	5,81E-04	7,27E-04	8,72E-04	
	POCP	kg NMVOC	1,66E-04	2,07E-04	2,48E-04	

PHASES FASI	PEI	UM	A	B	C
	ADPe	kg Sb eq	1,06E-07	1,33E-07	1,60E-07
	ADPf	MJ	4,54E-01	5,68E-01	6,81E-01
	WDP	m3 depriv.	1,60E-03	2,00E-03	2,40E-03
	ODP	kg CFC-11 eq	5,33E-09	6,66E-09	8,00E-09
C3	GWPF	kg CO2 eq	0,00E+00	0,00E+00	0,00E+00
	GWpb	kg CO2 eq	0,00E+00	0,00E+00	0,00E+00
	GWPI	kg CO2 eq	0,00E+00	0,00E+00	0,00E+00
	GWP	kg CO2 eq	0,00E+00	0,00E+00	0,00E+00
	AP	mol H+ eq	0,00E+00	0,00E+00	0,00E+00
	EPf	kg P eq	0,00E+00	0,00E+00	0,00E+00
	EPm	kg N eq	0,00E+00	0,00E+00	0,00E+00
	Ept	mol N eq	0,00E+00	0,00E+00	0,00E+00
	POCP	kg NMVOC	0,00E+00	0,00E+00	0,00E+00
	ADPe	kg Sb eq	0,00E+00	0,00E+00	0,00E+00
	ADPf	MJ	0,00E+00	0,00E+00	0,00E+00
	WDP	m3 depriv.	0,00E+00	0,00E+00	0,00E+00
	ODP	kg CFC-11 eq	0,00E+00	0,00E+00	0,00E+00
	C4	GWPF	kg CO2 eq	4,86E-03	6,07E-03
GWpb		kg CO2 eq	2,75E-02	3,43E-02	4,12E-02
GWPI		kg CO2 eq	4,97E-06	6,21E-06	7,46E-06
GWP		kg CO2 eq	3,23E-02	4,04E-02	4,85E-02
AP		mol H+ eq	4,29E-05	5,36E-05	6,44E-05
EPf		kg P eq	1,18E-06	1,47E-06	1,77E-06
EPm		kg N eq	1,62E-04	2,02E-04	2,43E-04
Ept		mol N eq	1,65E-04	2,07E-04	2,48E-04
POCP		kg NMVOC	5,68E-05	7,10E-05	8,52E-05
ADPe		kg Sb eq	1,60E-08	2,00E-08	2,40E-08
ADPf		MJ	1,07E-01	1,34E-01	1,61E-01
WDP		m3 depriv.	4,28E-03	5,35E-03	6,41E-03
ODP		kg CFC-11 eq	1,10E-09	1,38E-09	1,66E-09
D		GWPF	kg CO2 eq	0,00E+00	0,00E+00
	GWpb	kg CO2 eq	0,00E+00	0,00E+00	0,00E+00
	GWPI	kg CO2 eq	0,00E+00	0,00E+00	0,00E+00
	GWP	kg CO2 eq	0,00E+00	0,00E+00	0,00E+00
	AP	mol H+ eq	0,00E+00	0,00E+00	0,00E+00
	EPf	kg P eq	0,00E+00	0,00E+00	0,00E+00
	EPm	kg N eq	0,00E+00	0,00E+00	0,00E+00

PHASES FASI	PEI	UM	A	B	C
	<i>EPt</i>	<i>mol N eq</i>	0,00E+00	0,00E+00	0,00E+00
	<i>POCP</i>	<i>kg NMVOC</i>	0,00E+00	0,00E+00	0,00E+00
	<i>ADPe</i>	<i>kg Sb eq</i>	0,00E+00	0,00E+00	0,00E+00
	<i>ADPf</i>	<i>MJ</i>	0,00E+00	0,00E+00	0,00E+00
	<i>WDP</i>	<i>m3 depriv.</i>	0,00E+00	0,00E+00	0,00E+00
	<i>ODP</i>	<i>kg CFC-11 eq</i>	0,00E+00	0,00E+00	0,00E+00

Environmental performance of Solid Wood Lamella – Use of resources

Performance ambientali delle lamelle in legno massello – Consumo di risorse

Class legend – Material and weight class (kg)

Legenda Classi – Materiale e Classe di peso (Kg)

A:	<i>Solid Wood lamella, solid fir wood</i>	<i>24 kg/mq</i>
B:	<i>Solid Wood lamella, solid fir wood</i>	<i>30 kg/mq</i>
C:	<i>Solid Wood lamella, solid fir wood</i>	<i>36 kg/mq</i>

Legend – Potential environmental impact:

Legenda impatti:

PEI Potential environment impact

UM Unit of measure

GWP	Global warming potential, total
GWPf	Global warming potential, fossil
GWPb	Global warming potential, biogenic
GWPI	Global warming potential, land use
ODP	Ozone depletion potential
AP	Acidification potential of land and water
EPf	Eutrophication aquatic, freshwater
EPm	Eutrophication aquatic, marine
EPT	Eutrophication aquatic, terrestrial
POCP	Photochemical ozone creation potential
ADPe	Abiotic depletion potential, elements
ADPf	Abiotic depletion potential, fossil
WDP	Water depletion potential

Functional Unit: 1 m² of ceiling/wall covering

Unità funzionale: 1 m² di controsoffitto/rivestimento

PHASES FASI	PEI	UM	A	B	C
A1	PERE	MJ	7,97E-03	1,19E-02	0,00E+00
	PERM	MJ	2,45E+01	3,68E+01	0,00E+00
	PERT	MJ	2,45E+01	3,68E+01	0,00E+00
	PENRE	MJ	7,16E-01	1,07E+00	0,00E+00
	PENRM	MJ	0,00E+00	0,00E+00	0,00E+00
	PENRT	MJ	7,16E-01	1,07E+00	0,00E+00
	SM	kg	0,00E+00	0,00E+00	0,00E+00
	RSF	MJ	0,00E+00	0,00E+00	0,00E+00
	NRSF	MJ	0,00E+00	0,00E+00	0,00E+00
	FW	m3	1,27E-03	1,91E-03	0,00E+00
A2	PERE	MJ	3,18E-03	4,78E-03	0,00E+00
	PERM	MJ	9,37E-04	1,41E-03	0,00E+00
	PERT	MJ	4,12E-03	6,18E-03	0,00E+00
	PENRE	MJ	3,16E-01	4,75E-01	0,00E+00
	PENRM	MJ	0,00E+00	0,00E+00	0,00E+00
	PENRT	MJ	3,16E-01	4,75E-01	0,00E+00
	SM	kg	0,00E+00	0,00E+00	0,00E+00
	RSF	MJ	0,00E+00	0,00E+00	0,00E+00
	NRSF	MJ	0,00E+00	0,00E+00	0,00E+00
	FW	m3	2,87E-04	4,31E-04	0,00E+00
A3	PERE	MJ	4,14E-01	6,21E-01	0,00E+00
	PERM	MJ	2,37E-01	3,55E-01	0,00E+00
	PERT	MJ	6,51E-01	9,76E-01	0,00E+00
	PENRE	MJ	6,70E+00	1,01E+01	0,00E+00
	PENRM	MJ	1,75E+00	2,62E+00	0,00E+00
	PENRT	MJ	8,45E+00	1,27E+01	0,00E+00
	SM	kg	0,00E+00	0,00E+00	0,00E+00
	RSF	MJ	0,00E+00	0,00E+00	0,00E+00
	NRSF	MJ	0,00E+00	0,00E+00	0,00E+00
	FW	m3	4,17E-02	6,25E-02	0,00E+00
A4	PERE	MJ	1,85E-02	2,78E-02	0,00E+00
	PERM	MJ	7,18E-03	1,08E-02	0,00E+00
	PERT	MJ	2,57E-02	3,86E-02	0,00E+00
	PENRE	MJ	2,26E+00	3,40E+00	0,00E+00
	PENRM	MJ	0,00E+00	0,00E+00	0,00E+00
	PENRT	MJ	2,26E+00	3,40E+00	0,00E+00
	SM	kg	0,00E+00	0,00E+00	0,00E+00

PHASES FASI	PEI	UM	A	B	C	
	RSF	MJ	0,00E+00	0,00E+00	0,00E+00	
	NRSF	MJ	0,00E+00	0,00E+00	0,00E+00	
	FW	m3	1,64E-03	2,46E-03	0,00E+00	
C1	PERE	MJ	0,00E+00	0,00E+00	0,00E+00	
	PERM	MJ	0,00E+00	0,00E+00	0,00E+00	
	PERT	MJ	0,00E+00	0,00E+00	0,00E+00	
	PENRE	MJ	0,00E+00	0,00E+00	0,00E+00	
	PENRM	MJ	0,00E+00	0,00E+00	0,00E+00	
	PENRT	MJ	0,00E+00	0,00E+00	0,00E+00	
	SM	kg	0,00E+00	0,00E+00	0,00E+00	
	RSF	MJ	0,00E+00	0,00E+00	0,00E+00	
	NRSF	MJ	0,00E+00	0,00E+00	0,00E+00	
	FW	m3	0,00E+00	0,00E+00	0,00E+00	
	C2	PERE	MJ	3,75E-03	5,63E-03	0,00E+00
		PERM	MJ	1,57E-03	2,35E-03	0,00E+00
PERT		MJ	5,32E-03	7,98E-03	0,00E+00	
PENRE		MJ	4,54E-01	6,81E-01	0,00E+00	
PENRM		MJ	0,00E+00	0,00E+00	0,00E+00	
PENRT		MJ	4,54E-01	6,81E-01	0,00E+00	
SM		kg	0,00E+00	0,00E+00	0,00E+00	
RSF		MJ	0,00E+00	0,00E+00	0,00E+00	
NRSF		MJ	0,00E+00	0,00E+00	0,00E+00	
FW		m3	3,71E-04	5,57E-04	0,00E+00	
C3		PERE	MJ	0,00E+00	0,00E+00	0,00E+00
		PERM	MJ	0,00E+00	0,00E+00	0,00E+00
	PERT	MJ	0,00E+00	0,00E+00	0,00E+00	
	PENRE	MJ	0,00E+00	0,00E+00	0,00E+00	
	PENRM	MJ	0,00E+00	0,00E+00	0,00E+00	
	PENRT	MJ	0,00E+00	0,00E+00	0,00E+00	
	SM	kg	0,00E+00	0,00E+00	0,00E+00	
	RSF	MJ	0,00E+00	0,00E+00	0,00E+00	
	NRSF	MJ	0,00E+00	0,00E+00	0,00E+00	
	FW	m3	0,00E+00	0,00E+00	0,00E+00	
	C4	PERE	MJ	1,53E-03	2,29E-03	0,00E+00
		PERM	MJ	5,13E-04	7,69E-04	0,00E+00
PERT		MJ	2,04E-03	3,06E-03	0,00E+00	
PENRE		MJ	1,07E-01	1,61E-01	0,00E+00	

PHASES FASI	PEI	UM	A	B	C
	<i>PENRM</i>	<i>MJ</i>	0,00E+00	0,00E+00	0,00E+00
	<i>PENRT</i>	<i>MJ</i>	1,07E-01	1,61E-01	0,00E+00
	<i>SM</i>	<i>kg</i>	0,00E+00	0,00E+00	0,00E+00
	<i>RSF</i>	<i>MJ</i>	0,00E+00	0,00E+00	0,00E+00
	<i>NRSF</i>	<i>MJ</i>	0,00E+00	0,00E+00	0,00E+00
	<i>FW</i>	<i>m3</i>	2,36E-04	3,54E-04	0,00E+00
D	<i>PERE</i>	<i>MJ</i>	0,00E+00	0,00E+00	0,00E+00
	<i>PERM</i>	<i>MJ</i>	0,00E+00	0,00E+00	0,00E+00
	<i>PERT</i>	<i>MJ</i>	0,00E+00	0,00E+00	0,00E+00
	<i>PENRE</i>	<i>MJ</i>	0,00E+00	0,00E+00	0,00E+00
	<i>PENRM</i>	<i>MJ</i>	0,00E+00	0,00E+00	0,00E+00
	<i>PENRT</i>	<i>MJ</i>	0,00E+00	0,00E+00	0,00E+00
	<i>SM</i>	<i>kg</i>	0,00E+00	0,00E+00	0,00E+00
	<i>RSF</i>	<i>MJ</i>	0,00E+00	0,00E+00	0,00E+00
	<i>NRSF</i>	<i>MJ</i>	0,00E+00	0,00E+00	0,00E+00
	<i>FW</i>	<i>m3</i>	0,00E+00	0,00E+00	0,00E+00

Environmental performance of Solid Wood Lamella - Waste production and output flows

Performance ambientali delle lamelle in legno massello - Produzione di rifiuti e flussi in output

Class legend – Material and weight class (kg)

Legenda Classi – Materiale e Classe di peso (Kg)

A:	<i>Solid Wood lamella, solid fir wood</i>	<i>24 kg/mq</i>
B:	<i>Solid Wood lamella, solid fir wood</i>	<i>30 kg/mq</i>
C:	<i>Solid Wood lamella, solid fir wood</i>	<i>36 kg/mq</i>

Legend – Potential environmental impact:

Legenda impatti:

PEI Potential environment impact

UM Unit of measure

GWP	Global warming potential, total
GWPf	Global warming potential, fossil
GWPb	Global warming potential, biogenic
GWPI	Global warming potential, land use
ODP	Ozone depletion potential
AP	Acidification potential of land and water
EPf	Eutrophication aquatic, freshwater
EPm	Eutrophication aquatic, marine
EPT	Eutrophication aquatic, terrestrial
POCP	Photochemical ozone creation potential
ADPe	Abiotic depletion potential, elements
ADPf	Abiotic depletion potential, fossil
WDP	Water depletion potential

Functional Unit: 1 m² of ceiling/wall covering

Unità funzionale: 1 m² di controsoffitto/rivestimento

PHASES FASI	WASTE RIFIUTI	UM	A	B	C
A1	HWD	kg	4,42E-06	5,53E-06	6,63E-06
	NHWD	kg	5,34E-03	6,67E-03	8,01E-03
	RWD	kg	4,91E-06	6,14E-06	7,37E-06
A2	HWD	kg	7,80E-07	9,75E-07	1,17E-06
	NHWD	kg	3,02E-02	3,78E-02	4,53E-02
	RWD	kg	2,18E-06	2,73E-06	3,27E-06
A3	HWD	kg	9,79E-06	1,22E-05	1,47E-05
	NHWD	kg	1,97E-01	2,47E-01	2,96E-01
	RWD	kg	6,34E-06	7,93E-06	9,51E-06
A4	HWD	kg	4,70E-06	5,88E-06	7,05E-06
	NHWD	kg	7,99E-02	9,98E-02	1,20E-01
	RWD	kg	1,56E-05	1,95E-05	2,34E-05
C1	HWD	kg	0,00E+00	0,00E+00	0,00E+00
	NHWD	kg	0,00E+00	0,00E+00	0,00E+00
	RWD	kg	0,00E+00	0,00E+00	0,00E+00
C2	HWD	kg	1,22E-06	1,52E-06	1,82E-06
	NHWD	kg	2,34E-02	2,93E-02	3,51E-02
	RWD	kg	3,01E-06	3,76E-06	4,51E-06
C3	HWD	kg	0,00E+00	0,00E+00	0,00E+00
	NHWD	kg	0,00E+00	0,00E+00	0,00E+00
	RWD	kg	0,00E+00	0,00E+00	0,00E+00
C4	HWD	kg	1,73E-07	2,16E-07	2,59E-07
	NHWD	kg	1,63E+00	2,03E+00	2,44E+00
	RWD	kg	6,36E-07	7,95E-07	9,54E-07
D	HWD	kg	0,00E+00	0,00E+00	0,00E+00
	NHWD	kg	7,49E-01	9,37E-01	1,12E+00
	RWD	kg	0,00E+00	0,00E+00	0,00E+00
TOTAL TOTALE	HWD	kg	2,11E-05	2,64E-05	3,16E-05
	NHWD	kg	2,71E+00	3,39E+00	4,07E+00
	RWD	kg	3,27E-05	4,08E-05	4,90E-05

PHASES FASI	OUTPUT FLOWS FLUSSI IN OUTPUT	Unità	A	B	C
A1	CRU	kg	0,00E+00	0,00E+00	0,00E+00

PHASES FASI	OUTPUT FLOWS FLUSSI IN OUTPUT	Unità	A	B	C
	MFR	kg	0,00E+00	0,00E+00	0,00E+00
	MER	kg	0,00E+00	0,00E+00	0,00E+00
	EEE	MJ	0,00E+00	0,00E+00	0,00E+00
	EET	MJ	0,00E+00	0,00E+00	0,00E+00
A2	CRU	kg	0,00E+00	0,00E+00	0,00E+00
	MFR	kg	0,00E+00	0,00E+00	0,00E+00
	MER	kg	0,00E+00	0,00E+00	0,00E+00
	EEE	MJ	0,00E+00	0,00E+00	0,00E+00
A3	EET	MJ	0,00E+00	0,00E+00	0,00E+00
	CRU	kg	0,00E+00	0,00E+00	0,00E+00
	MFR	kg	0,00E+00	0,00E+00	0,00E+00
	MER	kg	0,00E+00	0,00E+00	0,00E+00
A4	EEE	MJ	0,00E+00	0,00E+00	0,00E+00
	EET	MJ	0,00E+00	0,00E+00	0,00E+00
	CRU	kg	0,00E+00	0,00E+00	0,00E+00
	MFR	kg	0,00E+00	0,00E+00	0,00E+00
C1	MER	kg	0,00E+00	0,00E+00	0,00E+00
	EEE	MJ	0,00E+00	0,00E+00	0,00E+00
	EET	MJ	0,00E+00	0,00E+00	0,00E+00
	CRU	kg	0,00E+00	0,00E+00	0,00E+00
C2	MFR	kg	0,00E+00	0,00E+00	0,00E+00
	MER	kg	0,00E+00	0,00E+00	0,00E+00
	EEE	MJ	0,00E+00	0,00E+00	0,00E+00
	EET	MJ	0,00E+00	0,00E+00	0,00E+00
C3	CRU	kg	0,00E+00	0,00E+00	0,00E+00
	MFR	kg	0,00E+00	0,00E+00	0,00E+00
	MER	kg	0,00E+00	0,00E+00	0,00E+00
	EEE	MJ	0,00E+00	0,00E+00	0,00E+00
C4	EET	MJ	0,00E+00	0,00E+00	0,00E+00
	CRU	kg	0,00E+00	0,00E+00	0,00E+00
	MFR	kg	0,00E+00	0,00E+00	0,00E+00
	MER	kg	0,00E+00	0,00E+00	0,00E+00

PHASES FASI	OUTPUT FLOWS FLUSSI IN OUTPUT	Unità	A	B	C
	<i>EEE</i>	<i>MJ</i>	0,00E+00	0,00E+00	0,00E+00
	<i>EET</i>	<i>MJ</i>	0,00E+00	0,00E+00	0,00E+00
D	<i>CRU</i>	<i>kg</i>	0,00E+00	0,00E+00	0,00E+00
	<i>MFR</i>	<i>kg</i>	-1,80E+01	-2,25E+01	-2,71E+01
	<i>MER</i>	<i>kg</i>	0,00E+00	0,00E+00	0,00E+00
	<i>EEE</i>	<i>MJ</i>	0,00E+00	0,00E+00	0,00E+00
	<i>EET</i>	<i>MJ</i>	0,00E+00	0,00E+00	0,00E+00

Environmental performance of structures – Impacts

Performance ambientali strutture- Impatti

Legend – Weight class (kg)

Legenda Classi – Classe di peso (kg)

A	Struttura “Unclick, click, inn, xline” “Unclick, click, inn, xline” structure	F	Struttura nascosta 200 Accessibile “Concealed 200 system Accesible” structure
B	Struttura Wood Lamella 300 301 “Wood Lamella 300 301” structure	G	Struttura nascosta 400 401 “Concealed 400 401 system” structure
C	Struttura Wood Lamella 302 504 “Wood Lamella 302 504” structure	H	Struttura nascosta CWI “Concealed CWI system” structure
D	Struttura nascosta 200 “Concealed 200 system” structure	I	Struttura rivestimenti 500, 501, 502, 503 “Coverings 500, 501, 502, 503 system” structure

Legend – Potential environmental impact:

Legenda impatti:

PEI Potential environment impact

UM Unit of measure

GWP	Global warming potential, total
GWPf	Global warming potential, fossil
GWPb	Global warming potential, biogenic
GWPI	Global warming potential, land use
ODP	Ozone depletion potential
AP	Acidification potential of land and water
EPf	Eutrophication aquatic, freshwater
EPm	Eutrophication aquatic, marine
EPt	Eutrophication aquatic, terrestrial
POCP	Photochemical ozone creation potential
ADPe	Abiotic depletion potential, elements
ADPf	Abiotic depletion potential, fossil
WDP	Water depletion potential

Functional Unit: 1 m² of ceiling/covering

Unità funzionale: 1 m² di controsoffitto/rivestimento

PHASES FASI	PEI	UM	A	B	C	D	E	F	G	H
A1	<i>GWPF</i>	<i>kg CO2 eq</i>	3,53E-01	4,07E-01	4,30E-01	4,24E-01	4,38E-01	4,30E-01	4,31E-01	4,34E-01
	<i>GWpb</i>	<i>kg CO2 eq</i>	1,19E-03	1,29E-03	1,32E-03	1,31E-03	1,32E-03	1,31E-03	1,31E-03	1,32E-03
	<i>GWPI</i>	<i>kg CO2 eq</i>	1,05E-03	1,59E-03	1,75E-03	1,31E-03	1,38E-03	1,34E-03	1,34E-03	1,36E-03
	<i>GWP</i>	<i>kg CO2 eq</i>	3,55E-01	4,10E-01	4,33E-01	4,27E-01	4,41E-01	4,33E-01	4,34E-01	4,37E-01
	<i>AP</i>	<i>mol H+ eq</i>	2,68E-03	3,02E-03	3,12E-03	3,00E-03	3,06E-03	3,03E-03	3,03E-03	3,05E-03
	<i>EPf</i>	<i>kg P eq</i>	2,51E-04	2,72E-04	2,82E-04	2,94E-04	3,01E-04	2,97E-04	2,97E-04	2,99E-04
	<i>EPm</i>	<i>kg N eq</i>	5,30E-04	5,91E-04	6,13E-04	6,05E-04	6,18E-04	6,10E-04	6,11E-04	6,14E-04
	<i>EPT</i>	<i>mol N eq</i>	5,99E-03	6,61E-03	6,83E-03	6,78E-03	6,92E-03	6,84E-03	6,85E-03	6,88E-03
	<i>POCP</i>	<i>kg NMVOC</i>	1,61E-03	1,89E-03	1,99E-03	1,91E-03	1,97E-03	1,93E-03	1,94E-03	1,95E-03
	<i>ADPe</i>	<i>kg Sb eq</i>	7,97E-05	8,29E-05	8,30E-05	8,28E-05	8,29E-05	8,28E-05	8,28E-05	8,28E-05
	<i>ADPf</i>	<i>MJ</i>	3,71E+00	4,42E+00	4,66E+00	4,34E+00	4,47E+00	4,39E+00	4,40E+00	4,43E+00
	<i>WDP</i>	<i>m3 eq</i>	2,18E-01	2,36E-01	2,47E-01	2,66E-01	2,75E-01	2,69E-01	2,70E-01	2,72E-01
	<i>ODP</i>	<i>kg CFC-11 eq</i>	2,26E-08	2,68E-08	2,81E-08	2,60E-08	2,67E-08	2,63E-08	2,64E-08	2,65E-08
A2	<i>GWPF</i>	<i>kg CO2 eq</i>	1,19E-02	1,38E-02	1,60E-02	2,14E-02	2,34E-02	2,22E-02	2,23E-02	2,28E-02
	<i>GWpb</i>	<i>kg CO2 eq</i>	3,14E-06	3,61E-06	4,21E-06	5,66E-06	6,19E-06	5,87E-06	5,91E-06	6,04E-06
	<i>GWPI</i>	<i>kg CO2 eq</i>	5,50E-06	6,46E-06	7,53E-06	9,85E-06	1,08E-05	1,02E-05	1,03E-05	1,05E-05
	<i>GWP</i>	<i>kg CO2 eq</i>	1,19E-02	1,38E-02	1,60E-02	2,14E-02	2,34E-02	2,22E-02	2,24E-02	2,28E-02
	<i>AP</i>	<i>mol H+ eq</i>	1,28E-04	1,57E-04	1,82E-04	2,28E-04	2,50E-04	2,37E-04	2,39E-04	2,44E-04
	<i>EPf</i>	<i>kg P eq</i>	7,77E-07	8,86E-07	1,03E-06	1,40E-06	1,53E-06	1,45E-06	1,46E-06	1,49E-06
	<i>EPm</i>	<i>kg N eq</i>	3,61E-05	4,36E-05	5,08E-05	6,43E-05	7,04E-05	6,68E-05	6,73E-05	6,87E-05
	<i>EPT</i>	<i>mol N eq</i>	3,98E-04	4,81E-04	5,61E-04	7,10E-04	7,77E-04	7,36E-04	7,42E-04	7,58E-04
	<i>POCP</i>	<i>kg NMVOC</i>	1,10E-04	1,33E-04	1,54E-04	1,96E-04	2,15E-04	2,04E-04	2,05E-04	2,10E-04
	<i>ADPe</i>	<i>kg Sb eq</i>	2,53E-08	2,90E-08	3,38E-08	4,56E-08	4,99E-08	4,73E-08	4,77E-08	4,87E-08
	<i>ADPf</i>	<i>MJ</i>	1,77E-01	2,03E-01	2,37E-01	3,17E-01	3,47E-01	3,29E-01	3,32E-01	3,39E-01
	<i>WDP</i>	<i>m3 depriv.</i>	6,26E-04	7,13E-04	8,30E-04	1,13E-03	1,23E-03	1,17E-03	1,18E-03	1,20E-03
	<i>ODP</i>	<i>kg CFC-11 eq</i>	2,11E-09	2,43E-09	2,83E-09	3,78E-09	4,14E-09	3,93E-09	3,95E-09	4,04E-09
A3	<i>GWPF</i>	<i>kg CO2 eq</i>	3,98E-03	3,24E-03	3,80E-03	7,52E-03	8,24E-03	7,81E-03	7,87E-03	8,04E-03
	<i>GWpb</i>	<i>kg CO2 eq</i>	8,21E-06	1,20E-05	1,50E-05	2,34E-05	1,70E-05	1,61E-05	1,63E-05	1,66E-05
	<i>GWPI</i>	<i>kg CO2 eq</i>	6,19E-07	2,08E-05	1,13E-06	1,76E-06	1,28E-06	1,22E-06	1,22E-06	1,25E-06
	<i>GWP</i>	<i>kg CO2 eq</i>	3,98E-03	3,27E-03	3,81E-03	7,54E-03	8,25E-03	7,83E-03	7,88E-03	8,05E-03
	<i>AP</i>	<i>mol H+ eq</i>	1,74E-05	1,43E-05	1,66E-05	3,29E-05	3,60E-05	3,41E-05	3,43E-05	3,51E-05
	<i>EPf</i>	<i>kg P eq</i>	9,06E-07	7,44E-07	8,67E-07	1,71E-06	1,88E-06	1,78E-06	1,79E-06	1,83E-06
	<i>EPm</i>	<i>kg N eq</i>	2,95E-06	2,43E-06	2,83E-06	5,59E-06	6,12E-06	5,80E-06	5,85E-06	5,97E-06
	<i>EPT</i>	<i>mol N eq</i>	3,12E-05	2,56E-05	2,99E-05	5,91E-05	6,46E-05	6,13E-05	6,17E-05	6,31E-05
	<i>POCP</i>	<i>kg NMVOC</i>	9,04E-06	7,42E-06	8,65E-06	1,71E-05	1,87E-05	1,78E-05	1,79E-05	1,83E-05
	<i>ADPe</i>	<i>kg Sb eq</i>	5,66E-09	4,65E-09	5,42E-09	1,07E-08	1,17E-08	1,11E-08	1,12E-08	1,14E-08
<i>ADPf</i>	<i>MJ</i>	5,32E-02	4,37E-02	5,09E-02	1,01E-01	1,10E-01	1,04E-01	1,05E-01	1,08E-01	

PHASES FASI	PEI	UM	A	B	C	D	E	F	G	H
	WDP	m3 depriv.	1,14E-03	9,35E-04	1,09E-03	2,15E-03	2,36E-03	2,23E-03	2,25E-03	2,30E-03
	ODP	kg CFC-11 eq	4,64E-10	3,81E-10	4,44E-10	8,79E-10	9,62E-10	9,12E-10	9,19E-10	9,38E-10
A4	GWPf	kg CO2 eq	9,32E-03	7,65E-03	8,90E-03	1,76E-02	1,93E-02	1,83E-02	1,84E-02	1,88E-02
	GWPb	kg CO2 eq	2,35E-06	1,93E-06	1,90E-05	4,18E-06	9,32E-06	4,62E-06	4,65E-06	4,75E-06
	GWPI	kg CO2 eq	4,97E-06	4,09E-06	6,23E-06	8,85E-06	1,97E-05	9,77E-06	9,84E-06	1,01E-05
	GWP	kg CO2 eq	9,32E-03	7,66E-03	8,92E-03	1,76E-02	1,93E-02	1,83E-02	1,84E-02	1,88E-02
	AP	mol H+ eq	1,45E-04	1,19E-04	1,39E-04	2,75E-04	3,01E-04	2,85E-04	2,87E-04	2,93E-04
	EPf	kg P eq	5,13E-07	4,21E-07	4,91E-07	9,70E-07	1,06E-06	1,01E-06	1,01E-06	1,04E-06
	EPm	kg N eq	3,86E-05	3,17E-05	3,69E-05	7,30E-05	7,99E-05	7,58E-05	7,63E-05	7,80E-05
	EPt	mol N eq	4,27E-04	3,51E-04	4,09E-04	8,08E-04	8,84E-04	8,39E-04	8,45E-04	8,63E-04
	POCP	kg NMVOC	1,13E-04	9,32E-05	1,09E-04	2,15E-04	2,35E-04	2,23E-04	2,24E-04	2,29E-04
	ADPe	kg Sb eq	2,53E-08	2,08E-08	2,42E-08	4,78E-08	5,23E-08	4,96E-08	5,00E-08	5,11E-08
	ADPf	MJ	1,32E-01	1,08E-01	1,26E-01	2,50E-01	2,74E-01	2,59E-01	2,61E-01	2,67E-01
	WDP	m3 depriv.	3,59E-04	2,95E-04	3,43E-04	6,79E-04	7,43E-04	7,04E-04	7,09E-04	7,25E-04
	ODP	kg CFC-11 eq	1,62E-09	1,33E-09	1,55E-09	3,07E-09	3,35E-09	3,18E-09	3,20E-09	3,27E-09
	C1	GWPf	kg CO2 eq	0,00E+00	0,00E+00	0,00E+00	0,00E+00	0,00E+00	0,00E+00	0,00E+00
GWPb		kg CO2 eq	0,00E+00	0,00E+00	0,00E+00	0,00E+00	0,00E+00	0,00E+00	0,00E+00	0,00E+00
GWPI		kg CO2 eq	0,00E+00	0,00E+00	0,00E+00	0,00E+00	0,00E+00	0,00E+00	0,00E+00	0,00E+00
GWP		kg CO2 eq	0,00E+00	0,00E+00	0,00E+00	0,00E+00	0,00E+00	0,00E+00	0,00E+00	0,00E+00
AP		mol H+ eq	0,00E+00	0,00E+00	0,00E+00	0,00E+00	0,00E+00	0,00E+00	0,00E+00	0,00E+00
EPf		kg P eq	0,00E+00	0,00E+00	0,00E+00	0,00E+00	0,00E+00	0,00E+00	0,00E+00	0,00E+00
EPm		kg N eq	0,00E+00	0,00E+00	0,00E+00	0,00E+00	0,00E+00	0,00E+00	0,00E+00	0,00E+00
EPt		mol N eq	0,00E+00	0,00E+00	0,00E+00	0,00E+00	0,00E+00	0,00E+00	0,00E+00	0,00E+00
POCP		kg NMVOC	0,00E+00	0,00E+00	0,00E+00	0,00E+00	0,00E+00	0,00E+00	0,00E+00	0,00E+00
ADPe		kg Sb eq	0,00E+00	0,00E+00	0,00E+00	0,00E+00	0,00E+00	0,00E+00	0,00E+00	0,00E+00
ADPf		MJ	0,00E+00	0,00E+00	0,00E+00	0,00E+00	0,00E+00	0,00E+00	0,00E+00	0,00E+00
WDP		m3 depriv.	0,00E+00	0,00E+00	0,00E+00	0,00E+00	0,00E+00	0,00E+00	0,00E+00	0,00E+00
ODP		kg CFC-11 eq	0,00E+00	0,00E+00	0,00E+00	0,00E+00	0,00E+00	0,00E+00	0,00E+00	0,00E+00
C2		GWPf	kg CO2 eq	1,79E-03	1,47E-03	1,71E-03	3,38E-03	3,70E-03	3,51E-03	3,54E-03
	GWPb	kg CO2 eq	4,95E-07	4,07E-07	4,74E-07	9,02E-07	1,41E-06	2,00E-06	9,79E-07	1,00E-06
	GWPI	kg CO2 eq	7,73E-07	6,35E-07	7,40E-07	1,41E-06	2,20E-06	3,12E-06	1,53E-06	1,56E-06
	GWP	kg CO2 eq	1,79E-03	1,47E-03	1,71E-03	3,39E-03	3,70E-03	3,51E-03	3,54E-03	3,62E-03
	AP	mol H+ eq	9,17E-06	7,53E-06	8,78E-06	1,74E-05	1,90E-05	1,80E-05	1,81E-05	1,85E-05
	EPf	kg P eq	1,36E-07	1,12E-07	1,30E-07	2,57E-07	2,82E-07	2,67E-07	2,69E-07	2,75E-07
	EPm	kg N eq	3,10E-06	2,55E-06	2,97E-06	5,87E-06	6,43E-06	6,10E-06	6,14E-06	6,27E-06
	EPt	mol N eq	3,39E-05	2,79E-05	3,25E-05	6,42E-05	7,03E-05	6,66E-05	6,71E-05	6,86E-05
	POCP	kg NMVOC	9,66E-06	7,93E-06	9,24E-06	1,83E-05	2,00E-05	1,90E-05	1,91E-05	1,95E-05

Environmental performance of structures – Use of resources

Performance ambientali strutture- Consumi di risorse

Structures legend

Legenda strutture

A	Struttura "Unclick, click, inn, xline" "Unclick, click, inn, xline" structure	F	Struttura nascosta 200 Accessibile "Concealed 200 system Accesible" structure
B	Struttura Wood Lamella 300 301 "Wood Lamella 300 301" structure	G	Struttura nascosta 400 401 "Concealed 400 401 system" structure
C	Struttura Wood Lamella 302 504 "Wood Lamella 302 504" structure	H	Struttura nascosta CWI "Concealed CWI system" structure
D	Struttura nascosta 200 "Concealed 200 system" structure	I	Struttura rivestimenti 500, 501, 502, 503 "Coverings 500, 501, 502, 503 system" structure

Legend – Use of resources:

Legenda - Consumi di risorse:

PEI	Potential environment impact
UM	Unit of measure
RPE	Renewable primary energy
PERE	Renewable primary energy excluding that one used as raw material
PERM	Renewable primary energy used as raw material
PERT	Total use of renewable primary energy
PENRE	Non-renewable primary energy excluding that one used as raw material
PENRM	Non-renewable primary energy used as raw material
PENRT	Total use of non-renewable primary energy
SM	Use of secondary raw materials
RSF	Use of renewable secondary fuels
NRSF	Use of non-renewable secondary fuels
FW	Net use of fresh water

Functional Unit: 1 m² of ceiling/covering

Unità funzionale: 1 m² di controsoffitto/rivestimento

PHASES FASI	PEI	UM	A	B	C	D	E	F	G	H
	<i>RSF</i>	<i>MJ</i>	0,00E+00	0,00E+00	0,00E+00	0,00E+00	0,00E+00	0,00E+00	0,00E+00	0,00E+00
	<i>NRSF</i>	<i>MJ</i>	0,00E+00	0,00E+00	0,00E+00	0,00E+00	0,00E+00	0,00E+00	0,00E+00	0,00E+00
	<i>FW</i>	<i>m3</i>	9,57E-05	7,86E-05	9,16E-05	1,81E-04	1,98E-04	1,88E-04	1,89E-04	1,93E-04
C1	<i>PERE</i>	<i>MJ</i>	0,00E+00	0,00E+00	0,00E+00	0,00E+00	0,00E+00	0,00E+00	0,00E+00	0,00E+00
	<i>PERM</i>	<i>MJ</i>	0,00E+00	0,00E+00	0,00E+00	0,00E+00	0,00E+00	0,00E+00	0,00E+00	0,00E+00
	<i>PERT</i>	<i>MJ</i>	0,00E+00	0,00E+00	0,00E+00	0,00E+00	0,00E+00	0,00E+00	0,00E+00	0,00E+00
	<i>PENRE</i>	<i>MJ</i>	0,00E+00	0,00E+00	0,00E+00	0,00E+00	0,00E+00	0,00E+00	0,00E+00	0,00E+00
	<i>PENRM</i>	<i>MJ</i>	0,00E+00	0,00E+00	0,00E+00	0,00E+00	0,00E+00	0,00E+00	0,00E+00	0,00E+00
	<i>PENRT</i>	<i>MJ</i>	0,00E+00	0,00E+00	0,00E+00	0,00E+00	0,00E+00	0,00E+00	0,00E+00	0,00E+00
	<i>SM</i>	<i>kg</i>	0,00E+00	0,00E+00	0,00E+00	0,00E+00	0,00E+00	0,00E+00	0,00E+00	0,00E+00
	<i>RSF</i>	<i>MJ</i>	0,00E+00	0,00E+00	0,00E+00	0,00E+00	0,00E+00	0,00E+00	0,00E+00	0,00E+00
	<i>NRSF</i>	<i>MJ</i>	0,00E+00	0,00E+00	0,00E+00	0,00E+00	0,00E+00	0,00E+00	0,00E+00	0,00E+00
	<i>FW</i>	<i>m3</i>	0,00E+00	0,00E+00	0,00E+00	0,00E+00	0,00E+00	0,00E+00	0,00E+00	0,00E+00
C2	<i>PERE</i>	<i>MJ</i>	2,19E-04	1,80E-04	2,09E-04	4,14E-04	4,53E-04	4,30E-04	4,33E-04	4,42E-04
	<i>PERM</i>	<i>MJ</i>	9,13E-05	7,50E-05	8,74E-05	1,73E-04	1,89E-04	1,79E-04	1,81E-04	1,85E-04
	<i>PERT</i>	<i>MJ</i>	3,10E-04	2,55E-04	2,97E-04	5,87E-04	6,43E-04	6,09E-04	6,14E-04	6,27E-04
	<i>PENRE</i>	<i>MJ</i>	2,65E-02	2,18E-02	2,54E-02	5,02E-02	5,49E-02	5,21E-02	5,24E-02	5,36E-02
	<i>PENRM</i>	<i>MJ</i>	0,00E+00	0,00E+00	0,00E+00	0,00E+00	0,00E+00	0,00E+00	0,00E+00	0,00E+00
	<i>PENRT</i>	<i>MJ</i>	2,65E-02	2,18E-02	2,54E-02	5,02E-02	5,49E-02	5,21E-02	5,24E-02	5,36E-02
	<i>SM</i>	<i>kg</i>	0,00E+00	0,00E+00	0,00E+00	0,00E+00	0,00E+00	0,00E+00	0,00E+00	0,00E+00
	<i>RSF</i>	<i>MJ</i>	0,00E+00	0,00E+00	0,00E+00	0,00E+00	0,00E+00	0,00E+00	0,00E+00	0,00E+00
	<i>NRSF</i>	<i>MJ</i>	0,00E+00	0,00E+00	0,00E+00	0,00E+00	0,00E+00	0,00E+00	0,00E+00	0,00E+00
	<i>FW</i>	<i>m3</i>	2,16E-05	1,78E-05	2,07E-05	4,10E-05	4,48E-05	4,25E-05	4,28E-05	4,37E-05
C3	<i>PERE</i>	<i>MJ</i>	0,00E+00	0,00E+00	0,00E+00	0,00E+00	0,00E+00	0,00E+00	0,00E+00	0,00E+00
	<i>PERM</i>	<i>MJ</i>	0,00E+00	0,00E+00	0,00E+00	0,00E+00	0,00E+00	0,00E+00	0,00E+00	0,00E+00
	<i>PERT</i>	<i>MJ</i>	0,00E+00	0,00E+00	0,00E+00	0,00E+00	0,00E+00	0,00E+00	0,00E+00	0,00E+00
	<i>PENRE</i>	<i>MJ</i>	0,00E+00	0,00E+00	0,00E+00	0,00E+00	0,00E+00	0,00E+00	0,00E+00	0,00E+00
	<i>PENRM</i>	<i>MJ</i>	0,00E+00	0,00E+00	0,00E+00	0,00E+00	0,00E+00	0,00E+00	0,00E+00	0,00E+00
	<i>PENRT</i>	<i>MJ</i>	0,00E+00	0,00E+00	0,00E+00	0,00E+00	0,00E+00	0,00E+00	0,00E+00	0,00E+00
	<i>SM</i>	<i>kg</i>	0,00E+00	0,00E+00	0,00E+00	0,00E+00	0,00E+00	0,00E+00	0,00E+00	0,00E+00
	<i>RSF</i>	<i>MJ</i>	0,00E+00	0,00E+00	0,00E+00	0,00E+00	0,00E+00	0,00E+00	0,00E+00	0,00E+00
	<i>NRSF</i>	<i>MJ</i>	0,00E+00	0,00E+00	0,00E+00	0,00E+00	0,00E+00	0,00E+00	0,00E+00	0,00E+00
	<i>FW</i>	<i>m3</i>	0,00E+00	0,00E+00	0,00E+00	0,00E+00	0,00E+00	0,00E+00	0,00E+00	0,00E+00
C4	<i>PERE</i>	<i>MJ</i>	8,93E-06	7,34E-06	8,55E-06	1,69E-05	1,85E-05	1,75E-05	1,77E-05	1,81E-05
	<i>PERM</i>	<i>MJ</i>	4,52E-06	3,71E-06	4,32E-06	8,55E-06	9,35E-06	8,87E-06	8,93E-06	9,13E-06
	<i>PERT</i>	<i>MJ</i>	1,34E-05	1,10E-05	1,29E-05	2,55E-05	2,79E-05	2,64E-05	2,66E-05	2,72E-05
	<i>PENRE</i>	<i>MJ</i>	1,53E-03	1,26E-03	1,46E-03	2,89E-03	3,17E-03	3,00E-03	3,02E-03	3,09E-03

Environmental performance of structures – Waste production and output flows

Performance ambientali structures - Produzione di rifiuti e flussi in output

Structures legend

Legenda strutture

A	Struttura "Unclick, click, inn, xline" "Unclick, click, inn, xline" structure	F	Struttura nascosta 200 Accessibile "Concealed 200 system Accesible" structure
B	Struttura Wood Lamella 300 301 "Wood Lamella 300 301" structure	G	Struttura nascosta 400 401 "Concealed 400 401 system" structure
C	Struttura Wood Lamella 302 504 "Wood Lamella 302 504" structure	H	Struttura nascosta CWI "Concealed CWI system" structure
D	Struttura nascosta 200 "Concealed 200 system" structure	I	Struttura rivestimenti 500, 501, 502, 503 "Coverings 500, 501, 502, 503 system" structure

Legend - Waste production and output flows:

Legenda – Produzione di rifiuti e flussi in output:

PEI	Potential environment impact
UM	Unit of measure
HWD	Hazardous waste disposed
NHWD	Non-hazardous waste disposed
RWD	Radioactive waste disposed
CRU	Components for re-use
MFR	Materials for recycling
MER	Materials for energy recovery
EEE	Exported energy, electricals
EET	Exported energy, thermal

Functional Unit: 1 m² of ceiling/rivestimento

Unità funzionale: 1 m² di controsoffitto/rivestimento

Environmental performance of Real veneer, thickness 2 mm - Impact

Performance ambientali dell'impiallacciato in legno naturale, spessore 2 mm - Impatti

Class legend – Material and weight class (kg)

Legenda Classi – Materiale e Classe di peso (Kg)

A: Maple 1,40 kg/mq
B: Wengè 1,90 kg/mq
C: Beech 144 kg/mq
D: Cherry 1,24 kg/mq
E: Zebrano 1,70 kg/mq

F: Ash tree 1,60 kg/mq
G: Walnut 1,40 kg/mq
H: Mahogany 1,70 kg/mq
I: Oak 1,60 kg/mq

Legend – Potential environmental impact:

Legenda impatti:

Functional Unit: 1 m² of ceiling/wall covering

Unità funzionale: 1 m² di controsoffitto/rivestimento

PEI Potential environment impact

UM Unit of measure

GWP Global warming potential, total
GWPf Global warming potential, fossil
GWPb Global warming potential, biogenic
GWPI Global warming potential, land use
ODP Ozone depletion potential
AP Acidification potential of land and water
EPf Eutrophication aquatic, freshwater
EPm Eutrophication aquatic, marine
EPT Eutrophication aquatic, terrestrial
POCP Photochemical ozone creation potential
ADPe Abiotic depletion potential, elements
ADPf Abiotic depletion potential, fossil
WDP Water depletion potential

PHASES	PEI	UM	A	B	C	D	E	F	G	H	I
FASI											
A1	GWPf	kg CO2 eq	3,35E-03	4,04E-03	3,57E-03	3,09E-03	3,71E-03	3,54E-03	3,51E-03	3,71E-03	3,84E-03
	GWPb	kg CO2 eq	9,10E-06	1,53E-05	1,56E-05	8,56E-06	1,46E-05	9,77E-06	1,39E-05	1,46E-05	1,46E-05
	GWPI	kg CO2 eq	3,04E-05	6,80E-05	7,89E-05	3,01E-05	6,77E-05	3,35E-05	6,70E-05	6,77E-05	6,73E-05
	GWP	kg CO2 eq	3,39E-03	4,12E-03	3,66E-03	3,13E-03	3,79E-03	3,58E-03	3,59E-03	3,79E-03	3,92E-03
	AP	mol H+ eq	1,66E-05	1,88E-05	1,78E-05	1,54E-05	1,74E-05	1,70E-05	1,76E-05	1,74E-05	1,91E-05
	EPf	kg P eq	9,82E-07	1,45E-06	1,40E-06	9,06E-07	1,35E-06	1,06E-06	1,30E-06	1,35E-06	1,40E-06
	EPm	kg N eq	4,23E-06	4,40E-06	4,63E-06	4,02E-06	4,13E-06	4,12E-06	4,61E-06	4,13E-06	4,88E-06
	EPT	mol N eq	4,39E-05	4,36E-05	4,58E-05	4,16E-05	4,08E-05	4,23E-05	4,62E-05	4,08E-05	4,90E-05
	POCP	kg NMVOC	1,96E-05	3,24E-05	3,52E-05	1,87E-05	3,13E-05	2,02E-05	3,18E-05	3,13E-05	3,29E-05
	ADPe	kg Sb eq	3,73E-08	5,05E-08	4,05E-08	3,34E-08	4,55E-08	4,20E-08	3,94E-08	4,55E-08	4,43E-08
	ADPf	MJ	5,50E-02	6,82E-02	5,89E-02	5,04E-02	6,25E-02	5,90E-02	5,77E-02	6,25E-02	6,34E-02
	WDP	m3 eq	1,28E-03	1,78E-03	1,63E-03	1,15E-03	1,62E-03	1,44E-03	1,57E-03	1,62E-03	1,73E-03
ODP	kg CFC-11 eq	4,97E-10	6,06E-10	5,38E-10	4,60E-10	5,61E-10	5,27E-10	5,27E-10	5,61E-10	5,72E-10	
A2	GWPf	kg CO2 eq	1,19E-03	1,61E-03	1,22E-03	1,05E-03	1,44E-03	1,36E-03	1,19E-03	1,44E-03	1,36E-03
	GWPb	kg CO2 eq	3,51E-07	4,76E-07	3,61E-07	3,11E-07	4,26E-07	4,01E-07	3,51E-07	4,26E-07	4,01E-07
	GWPI	kg CO2 eq	4,44E-07	6,03E-07	4,57E-07	3,93E-07	5,39E-07	5,07E-07	4,44E-07	5,39E-07	5,07E-07
	GWP	kg CO2 eq	1,19E-03	1,61E-03	1,22E-03	1,05E-03	1,44E-03	1,36E-03	1,19E-03	1,44E-03	1,36E-03
	AP	mol H+ eq	6,10E-06	8,28E-06	6,28E-06	5,40E-06	7,41E-06	6,97E-06	6,10E-06	7,41E-06	6,97E-06
	EPf	kg P eq	7,54E-08	1,02E-07	7,75E-08	6,67E-08	9,15E-08	8,61E-08	7,54E-08	9,15E-08	8,61E-08
	EPm	kg N eq	2,09E-06	2,84E-06	2,15E-06	1,85E-06	2,54E-06	2,39E-06	2,09E-06	2,54E-06	2,39E-06
	EPT	mol N eq	2,29E-05	3,11E-05	2,36E-05	2,03E-05	2,78E-05	2,62E-05	2,29E-05	2,78E-05	2,62E-05
	POCP	kg NMVOC	6,84E-06	9,29E-06	7,04E-06	6,06E-06	8,31E-06	7,82E-06	6,84E-06	8,31E-06	7,82E-06
	ADPe	kg Sb eq	2,78E-09	3,77E-09	2,86E-09	2,46E-09	3,37E-09	3,17E-09	2,78E-09	3,37E-09	3,17E-09
	ADPf	MJ	1,85E-02	2,51E-02	1,90E-02	1,64E-02	2,25E-02	2,11E-02	1,85E-02	2,25E-02	2,11E-02
	WDP	m3 depriv.	6,53E-05	8,86E-05	6,71E-05	5,78E-05	7,93E-05	7,46E-05	6,53E-05	7,93E-05	7,46E-05
ODP	kg CFC-11 eq	2,29E-10	3,10E-10	2,35E-10	2,03E-10	2,78E-10	2,61E-10	2,29E-10	2,78E-10	2,61E-10	
A3	GWPf	kg CO2 eq	2,89E-02	3,92E-02	2,97E-02	2,56E-02	3,51E-02	3,30E-02	2,89E-02	3,51E-02	3,30E-02
	GWPb	kg CO2 eq	8,41E-05	1,14E-04	8,65E-05	7,45E-05	1,02E-04	9,61E-05	8,41E-05	1,02E-04	9,61E-05
	GWPI	kg CO2 eq	7,30E-06	9,91E-06	7,51E-06	6,47E-06	8,87E-06	8,35E-06	7,30E-06	8,87E-06	8,35E-06
	GWP	kg CO2 eq	2,90E-02	3,94E-02	2,98E-02	2,57E-02	3,52E-02	3,31E-02	2,90E-02	3,52E-02	3,31E-02
	AP	mol H+ eq	1,28E-04	1,74E-04	1,32E-04	1,13E-04	1,55E-04	1,46E-04	1,28E-04	1,55E-04	1,46E-04
	EPf	kg P eq	6,52E-06	8,85E-06	6,71E-06	5,78E-06	7,92E-06	7,46E-06	6,52E-06	7,92E-06	7,46E-06
	EPm	kg N eq	2,26E-05	3,06E-05	2,32E-05	2,00E-05	2,74E-05	2,58E-05	2,26E-05	2,74E-05	2,58E-05
	EPT	mol N eq	2,38E-04	3,23E-04	2,45E-04	2,11E-04	2,89E-04	2,72E-04	2,38E-04	2,89E-04	2,72E-04
	POCP	kg NMVOC	6,82E-05	9,25E-05	7,01E-05	6,04E-05	8,28E-05	7,79E-05	6,82E-05	8,28E-05	7,79E-05
	ADPe	kg Sb eq	3,75E-08	5,09E-08	3,85E-08	3,32E-08	4,55E-08	4,28E-08	3,75E-08	4,55E-08	4,28E-08
	ADPf	MJ	3,87E-01	5,25E-01	3,98E-01	3,43E-01	4,70E-01	4,42E-01	3,87E-01	4,70E-01	4,42E-01
	WDP	m3 depriv.	8,02E-03	1,09E-02	8,25E-03	7,10E-03	9,74E-03	9,16E-03	8,02E-03	9,74E-03	9,16E-03
ODP	kg CFC-11 eq	3,39E-09	4,60E-09	3,49E-09	3,00E-09	4,12E-09	3,87E-09	3,39E-09	4,12E-09	3,87E-09	

PHASES	PEI	UM	A	B	C	D	E	F	G	H	I
FASI											
A4	<i>GWPf</i>	<i>kg CO2 eq</i>	9,32E-03	1,26E-02	9,58E-03	8,25E-03	1,13E-02	1,06E-02	9,32E-03	1,13E-02	1,06E-02
	<i>GWPb</i>	<i>kg CO2 eq</i>	2,35E-06	3,19E-06	2,42E-06	2,08E-06	2,86E-06	2,69E-06	2,35E-06	2,86E-06	2,69E-06
	<i>GWPI</i>	<i>kg CO2 eq</i>	4,97E-06	6,75E-06	5,12E-06	4,41E-06	6,04E-06	5,69E-06	4,97E-06	6,04E-06	5,69E-06
	<i>GWP</i>	<i>kg CO2 eq</i>	9,32E-03	1,27E-02	9,59E-03	8,26E-03	1,13E-02	1,07E-02	9,32E-03	1,13E-02	1,07E-02
	<i>AP</i>	<i>mol H+ eq</i>	1,45E-04	1,97E-04	1,49E-04	1,29E-04	1,76E-04	1,66E-04	1,45E-04	1,76E-04	1,66E-04
	<i>EPf</i>	<i>kg P eq</i>	5,13E-07	6,96E-07	5,27E-07	4,54E-07	6,22E-07	5,86E-07	5,13E-07	6,22E-07	5,86E-07
	<i>EPm</i>	<i>kg N eq</i>	3,86E-05	5,24E-05	3,97E-05	3,42E-05	4,69E-05	4,41E-05	3,86E-05	4,69E-05	4,41E-05
	<i>EPT</i>	<i>mol N eq</i>	4,27E-04	5,79E-04	4,39E-04	3,78E-04	5,18E-04	4,88E-04	4,27E-04	5,18E-04	4,88E-04
	<i>POCP</i>	<i>kg NMVOC</i>	1,13E-04	1,54E-04	1,17E-04	1,00E-04	1,38E-04	1,30E-04	1,13E-04	1,38E-04	1,30E-04
	<i>ADPe</i>	<i>kg Sb eq</i>	2,53E-08	3,43E-08	2,60E-08	2,24E-08	3,07E-08	2,89E-08	2,53E-08	3,07E-08	2,89E-08
	<i>ADPf</i>	<i>MJ</i>	1,32E-01	1,79E-01	1,36E-01	1,17E-01	1,60E-01	1,51E-01	1,32E-01	1,60E-01	1,51E-01
	<i>WDP</i>	<i>m3 depriv.</i>	3,59E-04	4,87E-04	3,69E-04	3,18E-04	4,35E-04	4,10E-04	3,59E-04	4,35E-04	4,10E-04
<i>ODP</i>	<i>kg CFC-11 eq</i>	1,62E-09	2,20E-09	1,67E-09	1,43E-09	1,97E-09	1,85E-09	1,62E-09	1,97E-09	1,85E-09	
C1	<i>GWPf</i>	<i>kg CO2 eq</i>	0,00E+00	0,00E+00	0,00E+00	0,00E+00	0,00E+00	0,00E+00	0,00E+00	0,00E+00	0,00E+00
	<i>GWPb</i>	<i>kg CO2 eq</i>	0,00E+00	0,00E+00	0,00E+00	0,00E+00	0,00E+00	0,00E+00	0,00E+00	0,00E+00	0,00E+00
	<i>GWPI</i>	<i>kg CO2 eq</i>	0,00E+00	0,00E+00	0,00E+00	0,00E+00	0,00E+00	0,00E+00	0,00E+00	0,00E+00	0,00E+00
	<i>GWP</i>	<i>kg CO2 eq</i>	0,00E+00	0,00E+00	0,00E+00	0,00E+00	0,00E+00	0,00E+00	0,00E+00	0,00E+00	0,00E+00
	<i>AP</i>	<i>mol H+ eq</i>	0,00E+00	0,00E+00	0,00E+00	0,00E+00	0,00E+00	0,00E+00	0,00E+00	0,00E+00	0,00E+00
	<i>EPf</i>	<i>kg P eq</i>	0,00E+00	0,00E+00	0,00E+00	0,00E+00	0,00E+00	0,00E+00	0,00E+00	0,00E+00	0,00E+00
	<i>EPm</i>	<i>kg N eq</i>	0,00E+00	0,00E+00	0,00E+00	0,00E+00	0,00E+00	0,00E+00	0,00E+00	0,00E+00	0,00E+00
	<i>EPT</i>	<i>mol N eq</i>	0,00E+00	0,00E+00	0,00E+00	0,00E+00	0,00E+00	0,00E+00	0,00E+00	0,00E+00	0,00E+00
	<i>POCP</i>	<i>kg NMVOC</i>	0,00E+00	0,00E+00	0,00E+00	0,00E+00	0,00E+00	0,00E+00	0,00E+00	0,00E+00	0,00E+00
	<i>ADPe</i>	<i>kg Sb eq</i>	0,00E+00	0,00E+00	0,00E+00	0,00E+00	0,00E+00	0,00E+00	0,00E+00	0,00E+00	0,00E+00
	<i>ADPf</i>	<i>MJ</i>	0,00E+00	0,00E+00	0,00E+00	0,00E+00	0,00E+00	0,00E+00	0,00E+00	0,00E+00	0,00E+00
	<i>WDP</i>	<i>m3 depriv.</i>	0,00E+00	0,00E+00	0,00E+00	0,00E+00	0,00E+00	0,00E+00	0,00E+00	0,00E+00	0,00E+00
<i>ODP</i>	<i>kg CFC-11 eq</i>	0,00E+00	0,00E+00	0,00E+00	0,00E+00	0,00E+00	0,00E+00	0,00E+00	0,00E+00	0,00E+00	
C2	<i>GWPf</i>	<i>kg CO2 eq</i>	1,79E-03	2,43E-03	1,84E-03	1,58E-03	2,17E-03	2,04E-03	1,79E-03	2,17E-03	2,04E-03
	<i>GWPb</i>	<i>kg CO2 eq</i>	4,95E-07	6,72E-07	5,09E-07	4,38E-07	6,01E-07	5,66E-07	4,95E-07	6,01E-07	5,66E-07
	<i>GWPI</i>	<i>kg CO2 eq</i>	7,73E-07	1,05E-06	7,95E-07	6,84E-07	9,38E-07	8,83E-07	7,73E-07	9,38E-07	8,83E-07
	<i>GWP</i>	<i>kg CO2 eq</i>	1,79E-03	2,43E-03	1,84E-03	1,58E-03	2,17E-03	2,04E-03	1,79E-03	2,17E-03	2,04E-03
	<i>AP</i>	<i>mol H+ eq</i>	9,17E-06	1,24E-05	9,43E-06	8,12E-06	1,11E-05	1,05E-05	9,17E-06	1,11E-05	1,05E-05
	<i>EPf</i>	<i>kg P eq</i>	1,36E-07	1,84E-07	1,40E-07	1,20E-07	1,65E-07	1,55E-07	1,36E-07	1,65E-07	1,55E-07
	<i>EPm</i>	<i>kg N eq</i>	3,10E-06	4,21E-06	3,19E-06	2,75E-06	3,77E-06	3,55E-06	3,10E-06	3,77E-06	3,55E-06
	<i>EPT</i>	<i>mol N eq</i>	3,39E-05	4,60E-05	3,49E-05	3,00E-05	4,12E-05	3,88E-05	3,39E-05	4,12E-05	3,88E-05
	<i>POCP</i>	<i>kg NMVOC</i>	9,66E-06	1,31E-05	9,93E-06	8,55E-06	1,17E-05	1,10E-05	9,66E-06	1,17E-05	1,10E-05
	<i>ADPe</i>	<i>kg Sb eq</i>	6,21E-09	8,43E-09	6,39E-09	5,50E-09	7,54E-09	7,09E-09	6,21E-09	7,54E-09	7,09E-09
	<i>ADPf</i>	<i>MJ</i>	2,65E-02	3,60E-02	2,73E-02	2,35E-02	3,22E-02	3,03E-02	2,65E-02	3,22E-02	3,03E-02
	<i>WDP</i>	<i>m3 depriv.</i>	9,35E-05	1,27E-04	9,62E-05	8,28E-05	1,14E-04	1,07E-04	9,35E-05	1,14E-04	1,07E-04
<i>ODP</i>	<i>kg CFC-11 eq</i>	3,11E-10	4,22E-10	3,20E-10	2,75E-10	3,78E-10	3,55E-10	3,11E-10	3,78E-10	3,55E-10	

Environmental performance of Real veneer, thickness 2 mm - Use of resources

Performance ambientali dell'impiallacciato in legno naturale, spessore 2 mm - Consumo di risorse

Class legend – Material and weight class (kg)

Legenda Classi – Materiale e Classe di peso (Kg)

A: Maple 1,40 kg/mq
B: Wengè 1,90 kg/mq
C: Beech 144 kg/mq
D: Cherry 1,24 kg/mq
E: Zebrano 1,70 kg/mq

F: Ash tree 1,60 kg/mq
G: Walnut 1,40 kg/mq
H: Mahogany 1,70 kg/mq
I: Oak 1,60 kg/mq

Legend – Potential environmental impact:

Legenda impatti:

PEI Potential environment impact

UM Unit of measure

GWP Global warming potential, total
GWPf Global warming potential, fossil
GWPb Global warming potential, biogenic
GWPI Global warming potential, land use
ODP Ozone depletion potential
AP Acidification potential of land and water
EPf Eutrophication aquatic, freshwater
EPm Eutrophication aquatic, marine
EPT Eutrophication aquatic, terrestrial
POCP Photochemical ozone creation potential
ADPe Abiotic depletion potential, elements
ADPf Abiotic depletion potential, fossil
WDP Water depletion potential

Functional Unit: 1 m² of ceiling/wall covering

Unità funzionale: 1 m² di controsoffitto/rivestimento

PHASES FASI	PEI	UM	A	B	C	D	E	F	G	H	I
	RSF	MJ	0,00E+00	0,00E+00	0,00E+00	0,00E+00	0,00E+00	0,00E+00	0,00E+00	0,00E+00	0,00E+00
	NRSF	MJ	0,00E+00	0,00E+00	0,00E+00	0,00E+00	0,00E+00	0,00E+00	0,00E+00	0,00E+00	0,00E+00
	FW	m3	9,57E-05	1,30E-04	9,84E-05	8,48E-05	1,16E-04	1,09E-04	9,57E-05	1,16E-04	1,09E-04
C1	PERE	MJ	0,00E+00	0,00E+00	0,00E+00	0,00E+00	0,00E+00	0,00E+00	0,00E+00	0,00E+00	0,00E+00
	PERM	MJ	0,00E+00	0,00E+00	0,00E+00	0,00E+00	0,00E+00	0,00E+00	0,00E+00	0,00E+00	0,00E+00
	PERT	MJ	0,00E+00	0,00E+00	0,00E+00	0,00E+00	0,00E+00	0,00E+00	0,00E+00	0,00E+00	0,00E+00
	PENRE	MJ	0,00E+00	0,00E+00	0,00E+00	0,00E+00	0,00E+00	0,00E+00	0,00E+00	0,00E+00	0,00E+00
	PENRM	MJ	0,00E+00	0,00E+00	0,00E+00	0,00E+00	0,00E+00	0,00E+00	0,00E+00	0,00E+00	0,00E+00
	PENRT	MJ	0,00E+00	0,00E+00	0,00E+00	0,00E+00	0,00E+00	0,00E+00	0,00E+00	0,00E+00	0,00E+00
	SM	kg	0,00E+00	0,00E+00	0,00E+00	0,00E+00	0,00E+00	0,00E+00	0,00E+00	0,00E+00	0,00E+00
	RSF	MJ	0,00E+00	0,00E+00	0,00E+00	0,00E+00	0,00E+00	0,00E+00	0,00E+00	0,00E+00	0,00E+00
	NRSF	MJ	0,00E+00	0,00E+00	0,00E+00	0,00E+00	0,00E+00	0,00E+00	0,00E+00	0,00E+00	0,00E+00
	FW	m3	0,00E+00	0,00E+00	0,00E+00	0,00E+00	0,00E+00	0,00E+00	0,00E+00	0,00E+00	0,00E+00
C2	PERE	MJ	2,19E-04	2,97E-04	2,25E-04	1,94E-04	2,66E-04	2,50E-04	2,19E-04	2,66E-04	2,50E-04
	PERM	MJ	9,13E-05	1,24E-04	9,40E-05	8,09E-05	1,11E-04	1,04E-04	9,13E-05	1,11E-04	1,04E-04
	PERT	MJ	3,10E-04	4,21E-04	3,19E-04	2,75E-04	3,77E-04	3,55E-04	3,10E-04	3,77E-04	3,55E-04
	PENRE	MJ	2,65E-02	3,60E-02	2,73E-02	2,35E-02	3,22E-02	3,03E-02	2,65E-02	3,22E-02	3,03E-02
	PENRM	MJ	0,00E+00	0,00E+00	0,00E+00	0,00E+00	0,00E+00	0,00E+00	0,00E+00	0,00E+00	0,00E+00
	PENRT	MJ	2,65E-02	3,60E-02	2,73E-02	2,35E-02	3,22E-02	3,03E-02	2,65E-02	3,22E-02	3,03E-02
	SM	kg	0,00E+00	0,00E+00	0,00E+00	0,00E+00	0,00E+00	0,00E+00	0,00E+00	0,00E+00	0,00E+00
	RSF	MJ	0,00E+00	0,00E+00	0,00E+00	0,00E+00	0,00E+00	0,00E+00	0,00E+00	0,00E+00	0,00E+00
	NRSF	MJ	0,00E+00	0,00E+00	0,00E+00	0,00E+00	0,00E+00	0,00E+00	0,00E+00	0,00E+00	0,00E+00
	FW	m3	2,16E-05	2,94E-05	2,23E-05	1,92E-05	2,63E-05	2,47E-05	2,16E-05	2,63E-05	2,47E-05
C3	PERE	MJ	0,00E+00	0,00E+00	0,00E+00	0,00E+00	0,00E+00	0,00E+00	0,00E+00	0,00E+00	0,00E+00
	PERM	MJ	0,00E+00	0,00E+00	0,00E+00	0,00E+00	0,00E+00	0,00E+00	0,00E+00	0,00E+00	0,00E+00
	PERT	MJ	0,00E+00	0,00E+00	0,00E+00	0,00E+00	0,00E+00	0,00E+00	0,00E+00	0,00E+00	0,00E+00
	PENRE	MJ	0,00E+00	0,00E+00	0,00E+00	0,00E+00	0,00E+00	0,00E+00	0,00E+00	0,00E+00	0,00E+00
	PENRM	MJ	0,00E+00	0,00E+00	0,00E+00	0,00E+00	0,00E+00	0,00E+00	0,00E+00	0,00E+00	0,00E+00
	PENRT	MJ	0,00E+00	0,00E+00	0,00E+00	0,00E+00	0,00E+00	0,00E+00	0,00E+00	0,00E+00	0,00E+00
	SM	kg	0,00E+00	0,00E+00	0,00E+00	0,00E+00	0,00E+00	0,00E+00	0,00E+00	0,00E+00	0,00E+00
	RSF	MJ	0,00E+00	0,00E+00	0,00E+00	0,00E+00	0,00E+00	0,00E+00	0,00E+00	0,00E+00	0,00E+00
	NRSF	MJ	0,00E+00	0,00E+00	0,00E+00	0,00E+00	0,00E+00	0,00E+00	0,00E+00	0,00E+00	0,00E+00
FW	m3	0,00E+00	0,00E+00	0,00E+00	0,00E+00	0,00E+00	0,00E+00	0,00E+00	0,00E+00	0,00E+00	
C4	PERE	MJ	8,91E-05	1,21E-04	9,16E-05	7,89E-05	1,08E-04	1,02E-04	8,91E-05	1,08E-04	1,02E-04
	PERM	MJ	2,99E-05	4,06E-05	3,08E-05	2,65E-05	3,63E-05	3,42E-05	2,99E-05	3,63E-05	3,42E-05
	PERT	MJ	1,19E-04	1,61E-04	1,22E-04	1,05E-04	1,44E-04	1,36E-04	1,19E-04	1,44E-04	1,36E-04
	PENRE	MJ	6,24E-03	8,47E-03	6,42E-03	5,53E-03	7,58E-03	7,14E-03	6,24E-03	7,58E-03	7,14E-03

Environmental performance of Real veneer, thickness 2 mm - Waste production and output flows

Performance ambientali dell'impiallacciato in legno naturale, spessore 2 mm - Produzione di rifiuti e flussi in output

Class legend – Material and weight class (kg)

Legenda Classi – Materiale e Classe di peso (Kg)

A: *Maple* 1,40 kg/mq
B: *Wengè* 1,90 kg/mq
C: *Beech* 144 kg/mq
D: *Cherry* 1,24 kg/mq
E: *Zebrano* 1,70 kg/mq

F: *Ash tree* 1,60 kg/mq
G: *Walnut* 1,40 kg/mq
H: *Mahogany* 1,70 kg/mq
I: *Oak* 1,60 kg/mq

Legend – Potential environmental impact:

Legenda impatti:

PEI Potential environment impact

UM Unit of measure

GWP Global warming potential, total
GWPf Global warming potential, fossil
GWPb Global warming potential, biogenic
GWPI Global warming potential, land use
ODP Ozone depletion potential
AP Acidification potential of land and water
EPf Eutrophication aquatic, freshwater
EPm Eutrophication aquatic, marine
EPT Eutrophication aquatic, terrestrial
POCP Photochemical ozone creation potential
ADPe Abiotic depletion potential, elements
ADPf Abiotic depletion potential, fossil
WDP Water depletion potential

Functional Unit: 1 m² of ceiling/wall covering

Unità funzionale: 1 m² di controsoffitto/rivestimento

Environmental performance of nonwoven fabric, thickness 0,5 mm – Impact *Performance ambientali del Tessuto non tessuto, spessore 0,5 mm – Impatti*

Class legend – Material and weight class (kg)

Legenda Classi – Materiale e Classe di peso (Kg)

A: *Nonwoven fabric* *0,054 kg/mq*

Legend – Potential environmental impact:

Legenda impatti:

PEI Potential environment impact

UM Unit of measure

GWP	Global warming potential, total
GWPf	Global warming potential, fossil
GWPb	Global warming potential, biogenic
GWPI	Global warming potential, land use
ODP	Ozone depletion potential
AP	Acidification potential of land and water
EPf	Eutrophication aquatic, freshwater
EPm	Eutrophication aquatic, marine
EPT	Eutrophication aquatic, terrestrial
POCP	Photochemical ozone creation potential
ADPe	Abiotic depletion potential, elements
ADPf	Abiotic depletion potential, fossil
WDP	Water depletion potential

Functional Unit: 1 m² of ceiling/wall covering

Unità funzionale: 1 m² di controsoffitto/rivestimento

PHASES FASI	PEI	UM	A
A1	<i>GWPf</i>	<i>kg CO2 eq</i>	5,60E-03
	<i>GWPb</i>	<i>kg CO2 eq</i>	6,07E-05
	<i>GWPI</i>	<i>kg CO2 eq</i>	9,37E-06
	GWP	kg CO2 eq	5,67E-03
	<i>AP</i>	<i>mol H+ eq</i>	4,85E-05
	<i>EPf</i>	<i>kg P eq</i>	2,09E-06
	<i>EPm</i>	<i>kg N eq</i>	8,68E-06
	<i>EPt</i>	<i>mol N eq</i>	1,32E-04
	<i>POCP</i>	<i>kg NMVOC</i>	2,54E-05
	<i>ADPe</i>	<i>kg Sb eq</i>	1,04E-07
	<i>ADPf</i>	<i>MJ</i>	6,53E-02
	<i>WDP</i>	<i>m3 eq</i>	1,61E-03
	<i>ODP</i>	<i>kg CFC-11 eq</i>	3,88E-10
	A2	<i>GWPf</i>	<i>kg CO2 eq</i>
<i>GWPb</i>		<i>kg CO2 eq</i>	6,21E-07
<i>GWPI</i>		<i>kg CO2 eq</i>	9,42E-07
GWP		kg CO2 eq	1,55E-03
<i>AP</i>		<i>mol H+ eq</i>	7,49E-06
<i>EPf</i>		<i>kg P eq</i>	1,46E-07
<i>EPm</i>		<i>kg N eq</i>	2,40E-06
<i>EPt</i>		<i>mol N eq</i>	2,62E-05
<i>POCP</i>		<i>kg NMVOC</i>	7,56E-06
<i>ADPe</i>		<i>kg Sb eq</i>	9,75E-09
<i>ADPf</i>		<i>MJ</i>	2,26E-02
<i>WDP</i>		<i>m3 depriv.</i>	9,02E-05
<i>ODP</i>		<i>kg CFC-11 eq</i>	2,72E-10
A3		<i>GWPf</i>	<i>kg CO2 eq</i>
	<i>GWPb</i>	<i>kg CO2 eq</i>	7,74E-06
	<i>GWPI</i>	<i>kg CO2 eq</i>	7,85E-07
	GWP	kg CO2 eq	1,26E-03
	<i>AP</i>	<i>mol H+ eq</i>	5,48E-06
	<i>EPf</i>	<i>kg P eq</i>	3,03E-07
	<i>EPm</i>	<i>kg N eq</i>	1,10E-06
	<i>EPt</i>	<i>mol N eq</i>	1,05E-05
	<i>POCP</i>	<i>kg NMVOC</i>	3,03E-06
	<i>ADPe</i>	<i>kg Sb eq</i>	2,17E-09
	<i>ADPf</i>	<i>MJ</i>	1,72E-02
	<i>WDP</i>	<i>m3 depriv.</i>	3,83E-04
	<i>ODP</i>	<i>kg CFC-11 eq</i>	1,40E-10
	A4	<i>GWPf</i>	<i>kg CO2 eq</i>
<i>GWPb</i>		<i>kg CO2 eq</i>	9,07E-08
<i>GWPI</i>		<i>kg CO2 eq</i>	1,92E-07
GWP		kg CO2 eq	3,60E-04
<i>AP</i>		<i>mol H+ eq</i>	5,60E-06
<i>EPf</i>		<i>kg P eq</i>	1,98E-08
<i>EPm</i>		<i>kg N eq</i>	1,49E-06
<i>EPt</i>		<i>mol N eq</i>	1,65E-05
<i>POCP</i>		<i>kg NMVOC</i>	4,38E-06
<i>ADPe</i>		<i>kg Sb eq</i>	9,75E-10
<i>ADPf</i>		<i>MJ</i>	5,09E-03
<i>WDP</i>		<i>m3 depriv.</i>	1,38E-05
<i>ODP</i>		<i>kg CFC-11 eq</i>	6,25E-11
C1		<i>GWPf</i>	<i>kg CO2 eq</i>
	<i>GWPb</i>	<i>kg CO2 eq</i>	0,00E+00
	<i>GWPI</i>	<i>kg CO2 eq</i>	0,00E+00
	GWP	kg CO2 eq	0,00E+00
	<i>AP</i>	<i>mol H+ eq</i>	0,00E+00

PHASES FASI	PEI	UM	A	
	EPf	kg P eq	0,00E+00	
	EPm	kg N eq	0,00E+00	
	Ept	mol N eq	0,00E+00	
	POCP	kg NMVOC	0,00E+00	
	ADPe	kg Sb eq	0,00E+00	
	ADPf	MJ	0,00E+00	
	WDP	m3 depriv.	0,00E+00	
	ODP	kg CFC-11 eq	0,00E+00	
C2	GWPf	kg CO2 eq	6,89E-05	
	GWPb	kg CO2 eq	1,91E-08	
	GWPI	kg CO2 eq	2,98E-08	
	GWP	kg CO2 eq	6,90E-05	
	AP	mol H+ eq	3,54E-07	
	EPf	kg P eq	5,24E-09	
	EPm	kg N eq	1,20E-07	
	Ept	mol N eq	1,31E-06	
	POCP	kg NMVOC	3,73E-07	
	ADPe	kg Sb eq	2,39E-10	
	ADPf	MJ	1,02E-03	
	WDP	m3 depriv.	3,61E-06	
	ODP	kg CFC-11 eq	1,20E-11	
	C3	GWPf	kg CO2 eq	0,00E+00
		GWPb	kg CO2 eq	0,00E+00
		GWPI	kg CO2 eq	0,00E+00
GWP		kg CO2 eq	0,00E+00	
AP		mol H+ eq	0,00E+00	
EPf		kg P eq	0,00E+00	
EPm		kg N eq	0,00E+00	
Ept		mol N eq	0,00E+00	
POCP		kg NMVOC	0,00E+00	
ADPe		kg Sb eq	0,00E+00	
ADPf		MJ	0,00E+00	
WDP		m3 depriv.	0,00E+00	
ODP		kg CFC-11 eq	0,00E+00	
C4		GWPf	kg CO2 eq	1,39E-03
		GWPb	kg CO2 eq	6,71E-08
		GWPI	kg CO2 eq	2,09E-08
	GWP	kg CO2 eq	1,39E-03	
	AP	mol H+ eq	7,89E-07	
	EPf	kg P eq	1,02E-07	
	EPm	kg N eq	4,26E-07	
	Ept	mol N eq	3,62E-06	
	POCP	kg NMVOC	9,02E-07	
	ADPe	kg Sb eq	2,26E-10	
	ADPf	MJ	6,54E-04	
	WDP	m3 depriv.	1,50E-05	
	ODP	kg CFC-11 eq	8,11E-12	
	D	GWPf	kg CO2 eq	0,00E+00
		GWPb	kg CO2 eq	0,00E+00
		GWPI	kg CO2 eq	0,00E+00
GWP		kg CO2 eq	0,00E+00	
AP		mol H+ eq	0,00E+00	
EPf		kg P eq	0,00E+00	
EPm		kg N eq	0,00E+00	
Ept		mol N eq	0,00E+00	
POCP	kg NMVOC	0,00E+00		
ADPe	kg Sb eq	0,00E+00		

PHASES FASI	PEI	UM	A
	<i>ADPf</i>	<i>MJ</i>	0,00E+00
	<i>WDP</i>	<i>m3 depriv.</i>	0,00E+00
	<i>ODP</i>	<i>kg CFC-11 eq</i>	0,00E+00

Environmental performance of nonwoven fabric, thickness 0,5 mm – Use of resouces

Performance ambientali del Tessuto non tessuto, spessore 0,5 mm – Consumo di risorse

Class legend – Material and weight class (kg)
Legenda Classi – Materiale e Classe di peso (Kg)

A: *Nonwoven fabric* *0,054 kg/mq*

Legend – Potential environmental impact:

Legenda impatti:

PEI Potential environment impact

UM Unit of measure

GWP	Global warming potential, total
GWPf	Global warming potential, fossil
GWPb	Global warming potential, biogenic
GWPI	Global warming potential, land use
ODP	Ozone depletion potential
AP	Acidification potential of land and water
EPf	Eutrophication acquatic, freshwater
EPm	Eutrophication acquatic, marine
EPT	Eutrophication acquatic, terrestrial
POCP	Photochemical ozone creation potential
ADPe	Abiotic depletion potential, elements
ADPf	Abiotic depletion potential, fossil
WDP	Water depletion potential

Functional Unit: 1 m² of ceiling/wall covering

Unità funzionale: 1 m² di controsoffitto/rivestimento

PHASES FASI	PEI	UM	A
A1	PERE	MJ	6,18E-03
	PERM	MJ	6,33E-03
	PERT	MJ	1,25E-02
	PENRE	MJ	6,53E-02
	PENRM	MJ	0,00E+00
	PENRT	MJ	6,53E-02
	SM	kg	0,00E+00
	RSF	MJ	0,00E+00
	NRSF	MJ	0,00E+00
	FW	m3	4,17E-04
A2	PERE	MJ	3,65E-04
	PERM	MJ	1,31E-04
	PERT	MJ	4,97E-04
	PENRE	MJ	2,26E-02
	PENRM	MJ	0,00E+00
	PENRT	MJ	2,26E-02
	SM	kg	0,00E+00
	RSF	MJ	0,00E+00
	NRSF	MJ	0,00E+00
	FW	m3	2,62E-05
A3	PERE	MJ	1,00E-03
	PERM	MJ	2,02E-03
	PERT	MJ	3,03E-03
	PENRE	MJ	1,72E-02
	PENRM	MJ	3,24E-02
	PENRT	MJ	4,96E-02
	SM	kg	0,00E+00
	RSF	MJ	0,00E+00
	NRSF	MJ	0,00E+00
	FW	m3	1,02E-04
A4	PERE	MJ	4,17E-05
	PERM	MJ	1,62E-05
	PERT	MJ	5,79E-05
	PENRE	MJ	5,09E-03
	PENRM	MJ	0,00E+00
	PENRT	MJ	5,09E-03
	SM	kg	0,00E+00
	RSF	MJ	0,00E+00
	NRSF	MJ	0,00E+00
	FW	m3	3,69E-06
C1	PERE	MJ	0,00E+00
	PERM	MJ	0,00E+00
	PERT	MJ	0,00E+00
	PENRE	MJ	0,00E+00
	PENRM	MJ	0,00E+00
	PENRT	MJ	0,00E+00
	SM	kg	0,00E+00
	RSF	MJ	0,00E+00
	NRSF	MJ	0,00E+00
	FW	m3	0,00E+00
C2	PERE	MJ	8,44E-06
	PERM	MJ	3,52E-06
	PERT	MJ	1,20E-05
	PENRE	MJ	1,02E-03
	PENRM	MJ	0,00E+00
	PENRT	MJ	1,02E-03
SM	kg	0,00E+00	

PHASES FASI	PEI	UM	A
	<i>RSF</i>	<i>MJ</i>	0,00E+00
	<i>NRSF</i>	<i>MJ</i>	0,00E+00
	<i>FW</i>	<i>m3</i>	8,35E-07
C3	<i>PERE</i>	<i>MJ</i>	0,00E+00
	<i>PERM</i>	<i>MJ</i>	0,00E+00
	<i>PERT</i>	<i>MJ</i>	0,00E+00
	<i>PENRE</i>	<i>MJ</i>	0,00E+00
	<i>PENRM</i>	<i>MJ</i>	0,00E+00
	<i>PENRT</i>	<i>MJ</i>	0,00E+00
	<i>SM</i>	<i>kg</i>	0,00E+00
	<i>RSF</i>	<i>MJ</i>	0,00E+00
	<i>NRSF</i>	<i>MJ</i>	0,00E+00
	<i>FW</i>	<i>m3</i>	0,00E+00
	C4	<i>PERE</i>	<i>MJ</i>
<i>PERM</i>		<i>MJ</i>	7,83E-06
<i>PERT</i>		<i>MJ</i>	3,63E-05
<i>PENRE</i>		<i>MJ</i>	6,54E-04
<i>PENRM</i>		<i>MJ</i>	0,00E+00
<i>PENRT</i>		<i>MJ</i>	6,54E-04
<i>SM</i>		<i>kg</i>	0,00E+00
<i>RSF</i>		<i>MJ</i>	0,00E+00
<i>NRSF</i>		<i>MJ</i>	0,00E+00
<i>FW</i>		<i>m3</i>	5,66E-06
D		<i>PERE</i>	<i>MJ</i>
	<i>PERM</i>	<i>MJ</i>	0,00E+00
	<i>PERT</i>	<i>MJ</i>	0,00E+00
	<i>PENRE</i>	<i>MJ</i>	0,00E+00
	<i>PENRM</i>	<i>MJ</i>	0,00E+00
	<i>PENRT</i>	<i>MJ</i>	0,00E+00
	<i>SM</i>	<i>kg</i>	0,00E+00
	<i>RSF</i>	<i>MJ</i>	0,00E+00
	<i>NRSF</i>	<i>MJ</i>	0,00E+00
	<i>FW</i>	<i>m3</i>	0,00E+00

Environmental performance of nonwoven fabric, thickness 0,5 mm – Waste production and output flows

Performance ambientali del Tessuto non tessuto, spessore 0,5 mm – Produzione di rifiuti e flussi in output

Class legend – Material and weight class (kg)

Legenda Classi – Materiale e Classe di peso (Kg)

A: *Nonwoven fabric* *0,054 kg/mq*

Legend – Potential environmental impact:

Legenda impatti:

PEI Potential environment impact

UM Unit of measure

GWP	Global warming potential, total
GWPf	Global warming potential, fossil
GWPb	Global warming potential, biogenic
GWPI	Global warming potential, land use
ODP	Ozone depletion potential
AP	Acidification potential of land and water
EPf	Eutrophication aquatic, freshwater
EPm	Eutrophication aquatic, marine
EPt	Eutrophication aquatic, terrestrial
POCP	Photochemical ozone creation potential
ADPe	Abiotic depletion potential, elements
ADPf	Abiotic depletion potential, fossil
WDP	Water depletion potential

Functional Unit: 1 m² of ceiling/wall covering

Unità funzionale: 1 m² di controsoffitto/rivestimento

PHASES FASI	WASTE RIFIUTI	UM	A
A1	HWD	kg	3,27E-07
	NHWD	kg	3,00E-03
	RWD	kg	3,01E-07
A2	HWD	kg	6,46E-08
	NHWD	kg	7,65E-04
	RWD	kg	1,54E-07
A3	HWD	kg	2,32E-08
	NHWD	kg	2,14E-04
	RWD	kg	1,87E-08
A4	HWD	kg	1,06E-08
	NHWD	kg	1,80E-04
	RWD	kg	3,51E-08
C1	HWD	kg	0,00E+00
	NHWD	kg	0,00E+00
	RWD	kg	0,00E+00
C2	HWD	kg	2,73E-09
	NHWD	kg	5,27E-05
	RWD	kg	6,76E-09
C3	HWD	kg	0,00E+00
	NHWD	kg	0,00E+00
	RWD	kg	0,00E+00
C4	HWD	kg	2,51E-09
	NHWD	kg	3,43E-03
	RWD	kg	2,48E-09
D	HWD	kg	0,00E+00
	NHWD	kg	0,00E+00
	RWD	kg	0,00E+00
TOTAL TOTALE	HWD	kg	4,30E-07
	NHWD	kg	7,64E-03
	RWD	kg	5,18E-07

PHASES FASI	OUTPUT FLOWS FLUSSI IN OUTPUT	Unità	A
A1	CRU	kg	0,00E+00
	MFR	kg	0,00E+00
	MER	kg	0,00E+00
	EEE	MJ	0,00E+00
	EET	MJ	0,00E+00
A2	CRU	kg	0,00E+00
	MFR	kg	0,00E+00
	MER	kg	0,00E+00
	EEE	MJ	0,00E+00
A3	EET	MJ	0,00E+00
	CRU	kg	0,00E+00
	MFR	kg	0,00E+00
A4	MER	kg	0,00E+00
	CRU	kg	0,00E+00
	MFR	kg	0,00E+00
	MER	kg	0,00E+00
C1	EEE	MJ	0,00E+00
	EET	MJ	0,00E+00
	CRU	kg	0,00E+00
	MFR	kg	0,00E+00
	MER	kg	0,00E+00
C2	EEE	MJ	0,00E+00
	EET	MJ	0,00E+00
	CRU	kg	0,00E+00
	MFR	kg	0,00E+00
C3	MER	kg	0,00E+00
	EEE	MJ	0,00E+00
	EET	MJ	0,00E+00
	CRU	kg	0,00E+00
	MFR	kg	0,00E+00
C4	MER	kg	0,00E+00
	EEE	MJ	0,00E+00
	EET	MJ	0,00E+00
	CRU	kg	0,00E+00
	MFR	kg	0,00E+00
D	MER	kg	0,00E+00
	EEE	MJ	0,00E+00
	EET	MJ	0,00E+00
	CRU	kg	0,00E+00

4. Glossary of main terms - *Glossario termini principali*

Global warming potential	Phenomenon in which the infra-red rays emitted by the earth's surface following solar warming are absorbed by the molecules in the atmosphere and released as heat, causing global warming of the atmosphere.	Potenziale di riscaldamento globale	<i>Fenomeno per il quale i raggi infrarossi emessi dalla superficie terrestre in seguito a riscaldamento solare sono assorbiti da molecole presenti in atmosfera e riemessi sotto forma di calore, determinando un riscaldamento globale dell'atmosfera stessa.</i>
Photochemical ozone creation potential	Production of compounds which, due to light, create an oxidation reaction causing the production of ozone in the troposphere.	Potenziale di formazione fotochimica di ozono	<i>Produzione di composti che, per azione della luce, sono in grado di promuovere una reazione di ossidazione che porta alla produzione di ozono nella troposfera.</i>
Acidification potential	Phenomenon in which atmospheric precipitations have a lower than normal pH.	Potenziale di acidificazione	<i>Fenomeno per il quale le precipitazioni atmosferiche risultano avere pH inferiore alla norma.</i>
Eutrophication potential	Concentration of nutrients in water courses which causes an imbalance in the aquatic ecosystems due to excessive development because of the lack of nutritional limitations.	Potenziale di eutrofizzazione	<i>Arricchimento in nutrienti dei corsi d'acqua, che determina squilibri negli ecosistemi acquatici dovuti all'eccessivo sviluppo per mancanza di limitazioni nutritive.</i>

5. Informations - Informazioni

PROGRAMME OPERATOR	PRODUCT CATEGORY	PCR REVIEW	VERIFICA INDIPENDENTE
<i>PROGRAMME OPERATOR</i>	<i>RULES (PCR)</i>		
<p>EPD Internationa AB. Box 210 60. SE-100 31 Stockholm Sweden Email: info@environdec.com</p>	<p>2019:14 Construction Products – version 1.11, valid until 2024-12-20.</p>	<p>The Technical Committee of the International EPD® System. A full list of members available on www.environdec.com. The review panel may be contacted via info@environdec.com.</p> <p>Chair of the PCR review: Claudia A. Peña</p> <p>Review dates: 2019-11-28 until 2019-12-18</p>	<p>Independent third-party verification of the declaration and data, according to ISO 14025:2006:</p> <p><input type="checkbox"/> EPD Process Certification</p> <p><input checked="" type="checkbox"/> EPD Verification</p>
<p><i>Il documento è stato sviluppato secondo il sistema dell'International EPD®.</i></p>			
<p><i>L'operatore del programma è:</i></p>			
<p><i>EPD International AB, Box 210 60, SE-100 31 Stoccolma, Svezia</i></p>		<p><i>Condotta da: Technical Committee of the International EPD® system</i></p>	<p><i>Verifica indipendente della dichiarazione e dei dati in accordo con la ISO 14025:2006:</i></p>
<p><i>E-mail: info@environdec.com</i></p>		<p><i>Chair: Claudia A. Peña</i></p> <p><i>Contattabile via email all'indirizzo: info@environtec.com</i></p>	<p><input type="checkbox"/> EPD Process Certification</p> <p><input checked="" type="checkbox"/> EPD Verification</p>
		<p>Data revisione: 28-11-2019 valida fino al 18-12-2019</p>	

THIRD PARTY VERIFICATION	TECHNICAL REPORT	CONTACTS	TECHNICAL SUPPORT
VERIFICA DI TERZA PARTE	RELAZIONE TECNICA	CONTATTI	SUPPORTO TECNICO
Dr. Guido Croce	<p>All detailed hypotheses of the study are reported in the LCA report.</p> <p>CBI Europe is the sole owner and has sole responsibility for the contents of the EPD</p> <p><i>Tutte le ipotesi di dettaglio dello studio sono riportate nel report LCA.</i></p> <p><i>CBI Europe è l'unico proprietario e ha l'esclusiva responsabilità dei contenuti dell'EPD.</i></p>	<p>For more information relating to the activities of CBI Europe or in this environmental declaration, please contact:</p> <p>Dr Roberto Marrocchini</p> <p>Email: r.marrocchini@cbi-europe.com</p> <p><i>Per ulteriori informazioni relative alle attività di CBI Europe o nei riguardi di questa EPD, contattare:</i></p> <p><i>Dr Roberto Marrocchini</i></p> <p>Email: r.marrocchini@cbi-europe.com</p>	<p>Coprai Group</p> <p>Via Federico Fellini, 2 – 65010 Spoltore (PE)</p>

PROCEDURE FOR FOLLOW-UP OF DATA

PROCEDURA PER IL FOLLOW-UP DEI DATI

During EPD validity involves third party verifier

Sì No

La procedura per il follow-up dei dati durante la validità dell'EPD coinvolge un verificatore di terze parti:

Sì No

6. References - Riferimenti

- Studio LCA, rev. 02 del 28.03.2022
- AIB – European Residual Mixes 2020. Version 1.0, 2021-05-31
- Agrifootprint vs. 5
- Ecoinvent (<http://www.ecoinvent.ch/>) – vs. 3.8
- International EPD System; General Programme Instructions for Environmental Product Declarations
- ISPRA – Istituto Superiore per la Protezione e la Ricerca Ambientale, Rapporto rifiuti urbani, 2021
- Norma ISO 14025 - Dichiarazioni ambientali di Tipo III - Principi e procedure
- UNI EN ISO 14040:2021 - Gestione ambientale - Valutazione del ciclo di vita - Principi e quadro di riferimento
- UNI EN ISO 14044:2021 - Gestione ambientale - Valutazione del ciclo di vita - Requisiti e linee guida
- PCR 2019:14 Construction Products – version 1.11, valid until 2024-12-20.